

XD 9004A
AKSWH01HE
5/16/2022

XLT[®]

SmartSolutions™



XLT Gas Oven & XLT Hood Installation & Operation Manual



CAUTION

Read This Manual Before Using This Appliance.

Current versions of this manual, Technical/Rough-In Specifications, Parts & Service Manual, Fire Suppression Installation, Architectural Drawings, & a list of International Authorized Distributors are available at: www.xltovens.com

For use with the following XLT Gas Oven Versions:

Australia (A)	H
Korea (K)	H
Standard (S)	H
World (W)	H

For use with the following XLT Gas Hood Versions:

Standard (S)	E
World (W)	E



Original Instructions

US: 888-443-2751 FAX: 316-943-2769 INTL: 316-943-2751 WEB: www.xltovens.com

XLT Ovens
PO Box 9090
Wichita, Kansas 67277



WARNING

Post in a prominent location instructions to be followed in the event you smell gas. This information can be obtained by consulting your local gas supplier.



WARNING

FOR YOUR SAFETY

Do not store or use gasoline or other flammable vapors and liquids on the vicinity of this or any other appliance



WARNING

Improper installation, adjustment, alteration, service or maintenance can cause property damage, injury, or death. Read the installation, operating and maintenance instructions thoroughly before installing or servicing this equipment.



WARNING

This appliance is not intended for use by persons (including children) with reduced physical, sensory or mental capabilities, or lack of experience and knowledge, unless they have been given supervision or instruction concerning use of the appliance by a person responsible for their safety.

XLT has spent millions of dollars designing and testing our products as well as developing Installation & Operation Manuals. These manuals are the most complete and easiest to understand in the industry. However, they are worthless if they are not followed.

We have witnessed store operators and building owners lose many thousands of dollars in lost revenue due to incorrect installations. We highly recommend you follow all instructions given in this manual as well as follow best practices in plumbing, electrical, and HVAC building codes.

Revision History Table

Revision	Comments	Date
	New Release - H Version Australia Information Included	09/10/2021
A	Alternate Oven Control Information Included	05/16/2022

Definitions & Symbols

A safety instruction (message) includes a “Safety Alert Symbol” & a signal word or phrase such as **DANGER**, **WARNING** or **CAUTION**. Each signal word has the following meaning:

	<p>Indicates a potentially hazardous situation that, if not avoided, can result in serious injury or death.</p>
<p>DANGER</p>	



	<p>Indicates a high voltage. It calls your attention to items or operations that could be dangerous to you & other persons operating this equipment. Read the message & follow the instructions carefully.</p>
<p>HIGH VOLTAGE</p>	

	<p>Indicates a potentially hazardous situation, that if not avoided, can result in cuts or being crushed. It calls your attention to items or operations that could be dangerous to you & other persons operating this equipment.</p>
<p>WARNING</p>	

	<p>Indicates a potentially hazardous situation, that if not avoided, can result in minor to moderate injury or serious damage to the product. The situation described in the CAUTION may, if not avoided, lead to serious results. Important safety measures are described in CAUTION (as well as WARNING), so be sure to observe them.</p>
<p>CAUTION</p>	

	<p>Notes indicates an area or subject of special merit, emphasizing either the product’s capability or common errors in operation or maintenance.</p>
<p>NOTE</p>	

	<p>Tips give a special instruction that can save time or provide other benefits while installing or using the product. The tip calls attention to an idea that may not be obvious to first-time users of the product.</p>
<p>TIP</p>	

	<p>Read the instructions before using this machine.</p>		<p>Terminal which is intended for connection to an external conductor.</p>
<p>READ</p>		<p>PROTECTIVE EARTH</p>	

**SAFETY DEPENDS ON YOU****CAUTION**

This appliance is for professional use by qualified personnel. This appliance must be installed by qualified persons in accordance with the regulations in force. This appliance must be installed with sufficient ventilation to prevent the occurrence of unacceptable concentrations of substances harmful to health in the room in which it is installed. This appliance needs an unobstructed flow of fresh air for satisfactory operation & must be installed in a suitably ventilated room in accordance with current regulations. This appliance should be serviced by qualified personnel at least every twelve (12) months or sooner if heavy use is expected.

**DANGER**

Installation and repairs of all electrical appliances & ventilation exhaust hoods should only be performed by a qualified professional who has read & understands these instructions & is familiar with proper safety precautions. Read this manual thoroughly before installing or servicing this equipment.

- Post in a prominent location instructions to be followed in the event you smell gas. This information can be obtained by consulting your local gas supplier.
- In the event a gas odor is detected, shut off the gas at the main shutoff valve immediately. Contact your local Gas Company or supplier.
- Do not restrict the flow of combustion and/or ventilation air to the unit. Provide adequate clearance for operating, cleaning, and maintaining & adequate clearance for operating the gas shutoff valve when the unit is in the installed position.
- Keep the area free & clear of combustible material. **DO NOT SPRAY AEROSOLS IN THE VICINITY OF THIS APPLIANCE WHILE IT IS IN OPERATION.**
- Ovens are certified for installation on combustible floors.
- Electrical schematics are located inside the control box of the oven, in this manual, and online at www.xltovens.com. Disconnect input power to the unit before performing any maintenance.
- This unit requires a ventilation hood that must conform to local codes.
- This unit may be operated with either natural gas or liquid petroleum fuel as designated on the data plate located on the side of the unit.
- This unit must be operated by the same voltage, phase, & frequency of electrical power as designated on the data plate located on the side of the unit.
- Minimum clearances must be maintained from combustible & non-combustible construction materials.
- Follow all local codes when installing this unit.
- Follow all local codes to electrically ground the unit.
- Appliance is not to be cleaned with water jet (high pressure water).
- XLT ovens are certified for use in stacks of up to four (4) units of XLT products. Integration of other manufacturer's products into an oven stack is not recommended, & voids any warranties. XLT assumes no liability for mixed product applications.
- Failure to call XLT Customer Service at 1-888-443-2751 prior to contacting a repair company voids any & all warranties.
- PLEASE RETAIN THIS MANUAL FOR FUTURE REFERENCE.

Warning & Safety Information..... 2

Warranty..... 6

General 8

Receiving & Inspection 9

Installation Responsibilities 10

Oven Description..... 12

Oven Crate Dimensions..... 15

Oven Dimensions & Weights..... 16

Oven Requirements 19

Oven Only Rough-In Specifications 28

Oven Assembly 31

Oven Connection..... 38

Oven Fire Suppression 39

Oven Ventilation Guidelines 41

Oven Initial Start-Up..... 42

Oven Operation 43

Oven Operator Controls 44

Oven Cleaning..... 50

Oven Maintenance..... 55

Oven Troubleshooting..... 56

Hood Installation 60

Hood Description 61

Hood and Shroud Crate Dimensions..... 62

Hood Dimensions & Weights..... 64

Recommended Exhaust Flow Rates..... 66

Hood Electrical Requirements..... 68

Hood Rough-In Specifications 69

Hood Electrical Connections..... 70

Hood Assembly 84

Hood Connection..... 102

Hood Initial Start-Up..... 104

Hood Operator Controls 105

Hood Valance Kit..... 106

Hood Duct Wrap Kit 109

Hood Cleaning..... 110

Electrical Schematics 112

Certifications 151

Start-Up Checklist 153

Typical Store Installation 154

Notes..... 155



Warranty - US and Canada

Rev J

Approval Date: 10/16/2019

XLT warrants Version H ovens manufactured after October 16, 2019 to be free from any defect in material and workmanship under normal use for seven (7) years from the date of original purchase by the end user, and further warrants main fan blades, conveyor shafts, and conveyor bearings for ten (10) years. XLT further warrants all ovens/hoods to be free from rust for ten (10) years from the date the equipment is originally purchased. XLT warrants Version E hoods manufactured after October 16, 2019 to be free from any defect in material and workmanship under normal use for seven (7) years from the date of original purchase by the end user purchaser. If the purchase includes a pre-piped Anusol system on both the ovens and hood, the warranty will be increased to ten (10) years on both pieces of equipment. In the event of a part failure, XLT will furnish a replacement part and pay for all labor associated with the replacement of the part. If upon inspection XLT determines that the part is not defective, all incurred costs will be the responsibility of the end user purchaser. This warranty is extended to the original end user purchaser and is not transferable without prior written consent of XLT. Damages are limited to the original purchase price.

DUTIES OF THE OWNER:

- The owner must inspect the equipment and crates at time of receipt. Damage during shipment is to be immediately reported to the carrier, XLT, and documented on the Bill of Lading
- The equipment must be installed and operated in accordance with the Installation and Operation Manual furnished with the unit
- This warranty shall not excuse the owner from properly maintaining the equipment in accordance with the Installation and Operation Manual furnished with the unit
- A copy of the "Initial Start-Up Checklist" must be filled out and returned to XLT when the unit is initially installed, and/or when the unit is removed and installed in another location
- The gas, electric, and HVAC utilities must be connected to the oven and installed by locally licensed contractors
- Failure to contact XLT prior to contacting a repair company for warranty work voids any and all warranties

WHAT IS NOT COVERED:

- Freight damage
- Overtime charges
- Any part that becomes defective because of utility services (power surges, high or low voltages, high or low gas pressure or volume, contaminated fuel, or improper utility connections)
- Any part that becomes defective because of moisture and/or other contaminants
- Conveyor belts
- Filters
- Exhaust Fans
- Light Bulbs
- Painted or Powder Coated surfaces
- Normal maintenance or adjustments
- This warranty shall not apply if the equipment or any part is damaged as a result of accident, casualty, alteration, misuse, abuse, improper cleaning, improper installation, improper operation, natural disasters, or man-made disasters

CLAIMS HANDLED AS FOLLOWS:

- Should any such defect be discovered, XLT must be notified. Upon notification, XLT will arrange for necessary repairs to be made by an authorized service agent. Denial of services upon the arrival of an authorized service agent will release XLT of any and all warranty obligations.





Warranty - International

Rev L

Approval Date: 06/01/2020

XLT warrants Version H ovens manufactured after October 16, 2019 to be free from any defect in material and workmanship under normal use for five (5) years from the date of original purchase by the end user, and further warrants main fan blades, conveyor shafts, and conveyor bearings for ten (10) years. XLT further warrants all ovens/hoods to be free from rust for ten (10) years from the date the equipment is originally purchased. XLT warrants Version E hoods manufactured after October 16, 2019 to be free from any defect in material and workmanship under normal use for five (5) years from the date of original purchase by the end user purchaser. If the purchase includes a hood and the ovens both the warranty will be increased to seven (7) years on both pieces of equipment. In the event of a part failure, XLT will furnish a replacement part and pay for all labor associated with the replacement of the part. If upon inspection XLT determines that the part is not defective, all incurred costs will be the responsibility of the end user purchaser. This warranty is extended to the original end user purchaser and is not transferable without prior written consent of XLT. Damages are limited to the original purchase price.

DUTIES OF THE OWNER:

- The owner must inspect the equipment and crates at time of receipt. Damage during shipment is to be immediately reported to the carrier and also to the Distributor/Service Provider
- The equipment must be installed and operated in accordance with the Installation and Operation Manual furnished with the unit
- This warranty shall not excuse the owner from properly maintaining the equipment in accordance with the Installation and Operation Manual furnished with the unit
- A copy of the "Initial Start-Up Checklist" must be filled out and returned to Distributor/Service Provider and to XLT when the unit is initially installed, and/or when the unit is removed and installed in another location
- The gas, electric, and HVAC utilities must be connected to the oven and installed by locally licensed contractors
- Failure to contact the Distributor/Service Provider prior to contacting a repair company for warranty work voids any and all warranties

WHAT IS NOT COVERED:

- Freight damage
- Overtime charges
- Any part that becomes defective because of utility services (power surges, high or low voltages, high or low gas pressure or volume, contaminated fuel, or improper utility connections)
- Any part that becomes defective because of moisture and/or other contaminants
- Conveyor belts
- Filters
- Exhaust Fans
- Light Bulbs
- Painted or Powder Coated surfaces
- Normal maintenance or adjustments
- This warranty shall not apply if the equipment or any part is damaged as a result of accident, casualty, alteration, misuse, abuse, improper cleaning, improper installation, improper operation, natural disasters, or man-made disasters

CLAIMS HANDLED AS FOLLOWS:

- Should any such defect be discovered, the Distributor/Service Provider must be notified. Upon notification, Distributor/Service Provider will arrange for necessary repairs to be made by an authorized service agent. Denial of services upon the arrival of an authorized service agent will release XLT and Distributor/Service Provider of any and all warranty obligations.

7761 W Kellogg Drive 67209-2003 - PO Box 9090 67277-0090 - Wichita, Kansas
Voice (316) 943-2751 - (888) 443-2751 - Fax (316) 943-2769
www.xltovens.com



Save this Manual

This document is the property of the owner of this equipment.

XLT reserves the right to make changes in design & specifications, and/or make additions to or improvements to its product without imposing any obligations upon itself to install them in products previously manufactured.

All Right Hand & Left Hand designations in this manual are from the point of view as seen below.

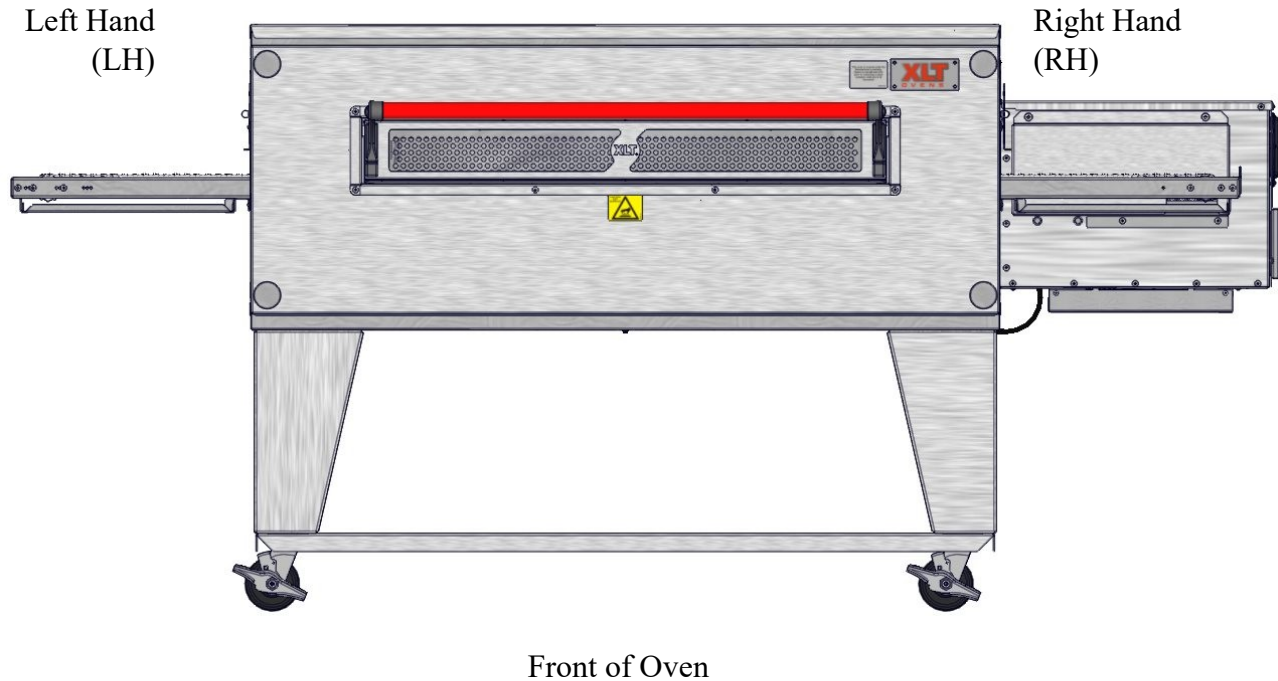

NOTIFY CARRIER OF DAMAGE AT ONCE

Upon receiving of all goods shipped by a Common Carrier, check for any exterior damage that may indicate interior damage. If conditions permit, open all crates & do a full inspection for any damage while the delivery driver is still there. If there is damage, please note on the delivery receipt & call the carrier to make a freight damage claim within 24 hours of receipt. Failure to make a damage claim within the first 24 hours may void the opportunity to have the claim resolved.

XLT wants you to be totally satisfied with every aspect of owning & using your oven & hood. Your feedback, both positive & negative, is very important to us as it helps us understand how to improve our products & our company. Our goal is to provide you with equipment that we are proud to build & you will be proud to own.

To receive technical support for the oven or hood you purchased, XLT has qualified customer service personnel that can provide assistance on any type of XLT equipment problem you may experience. Customer Service is available 24/7/365 at 888-443-2751 or visit www.xltovens.com.

Responsibility	Service Company	Owner/ Contractor
Assembly of new hood per XLT Installation & Operation Manual		X
Suspend XLT Hood from ceiling		X
Weld ducting to XLT Hood		X
Install new exhaust fan on roof		X
Supply power to XLT Hood		X
Install Duct Cover or Valance above XLT Hood		X
Supply wiring from TS1 R3, R4, R5 to exhaust fan		X
Assembly of new ovens per XLT Installation & Operation Manual	X	
Bases assembled and set in place	X	
Ovens moved and stacked with proper lifting equipment	X	
Peel all PVC	X	
Assemble shrouds & brackets to XLT Oven/Hood	X	
Connecting fuel to XLT products	X	
Supply power to XLT Oven(s)	X	
Install piping and drip legs	X	
Check for leaks	X	
Install flexible gas hoses	X	
Connection may require Permit and Code Inspections		X
Relocate Make-Up-Air to enter the room at the ends of the Ovens		X
Start-up per XLT Installation & Operation Manual:	X	
Start-Up Checklist has been filled out per Installation & Operation Manual	X	
Start-Up Checklist must be submitted to XLT to validate Warranty		X

**NOTE**

If XLT employees are completing the installation process, they will be considered a Service Company in regards to the above table.

**DANGER**

Installation of all gas appliances & ventilation exhaust hoods should only be performed by a qualified professional who has read & understands these instructions & is familiar with proper safety precautions. Read this manual thoroughly before installing or servicing this equipment.

This page is intentionally left blank.

This manual covers the following XLT Oven & Hood models:

Ovens	Hoods
X3H-1832-xxxxx	H3E-1832-xxxxx
X3H-2336-xxxxx	H3E-2440-xxxxx
X3H-2440-xxxxx	H3E-2440-xxxxx
X3H-3240-xxxxx	H3E-3240-xxxxx
X3H-3255-xxxxx	H3E-3255-xxxxx
X3H-3855-xxxxx	H3E-3855-xxxxx
X3H-4455-xxxxx	
X3H-3270-1B-xxxxx	H3E-3270-xxxxx
X3H-3270-2B-xxxxx	H3E-3270-xxxxx
X3H-3870-xxxxx	H3E-3870-xxxxx
X3H-3280-xxxxx	
X3H-3250-xxxxx-DS	
X3H-3265-xxxxx-DS	
X3H-3280-xxxxx-DS	
X3H-3880-xxxxx-DS	

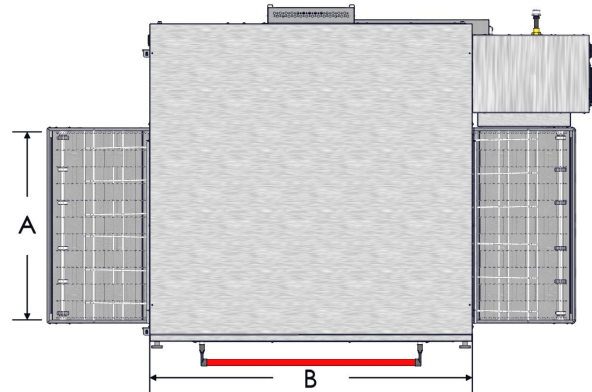

The first two (2) digits of the model number after the dash represent the conveyor belt width and the last two digits indicate the bake chamber length. For example, the X3H-3255-xxxx models would have a bake chamber with the width (A in image above) of 32 inches and the length (B in the image above) of 55 inches. The five (5) x's after those numbers represents the oven and hood configuration number. The 3265, 3270-2B, 3870, 3280, and 3880 models have two (2) burners, one on each side and have two (2) controls boxes. All other models have only a single burner with a single control box that can be supplied on either end. The DS models, noted at end of model number, may be used in a single or double stack configuration only. All other oven models may be used in a single, double, or triple stack configuration. All gas-fired ovens are available in Natural gas or Liquid Petroleum models (Electric ovens are also available in a variety of sizes). All models can be configured for a split belt conveyor.

OVEN DESCRIPTION

Food product is placed on the stainless steel wire conveyor belt on one side of the oven. The conveyor then transports the food through the bake chamber at a user-controlled speed. This provides repeatable and uniform food cooking. The conveyors can be easily configured to move either left-to-right or right-to-left with a simple programming change. A large optional center sandwich door allows the introduction of food items for cooking at shorter times. Precise temperatures are user adjustable and maintained by a digital control.

An easily removable front panel allows the full cleaning of the oven interior. All exposed oven surfaces both exterior and interior are stainless steel. The conveyor is a one piece design and is removed from the side which has the control box. Only a #2 Phillips head screwdriver is required for disassembly and cleaning of the conveyor or oven interior. The oven itself is mounted on lockable swivel casters for easy moving and maintenance.

XLT has available a variety of accessories for use with the ovens and hoods as well as the installation and moving of the equipment. Please contact XLT or your Authorized Distributor for more information.

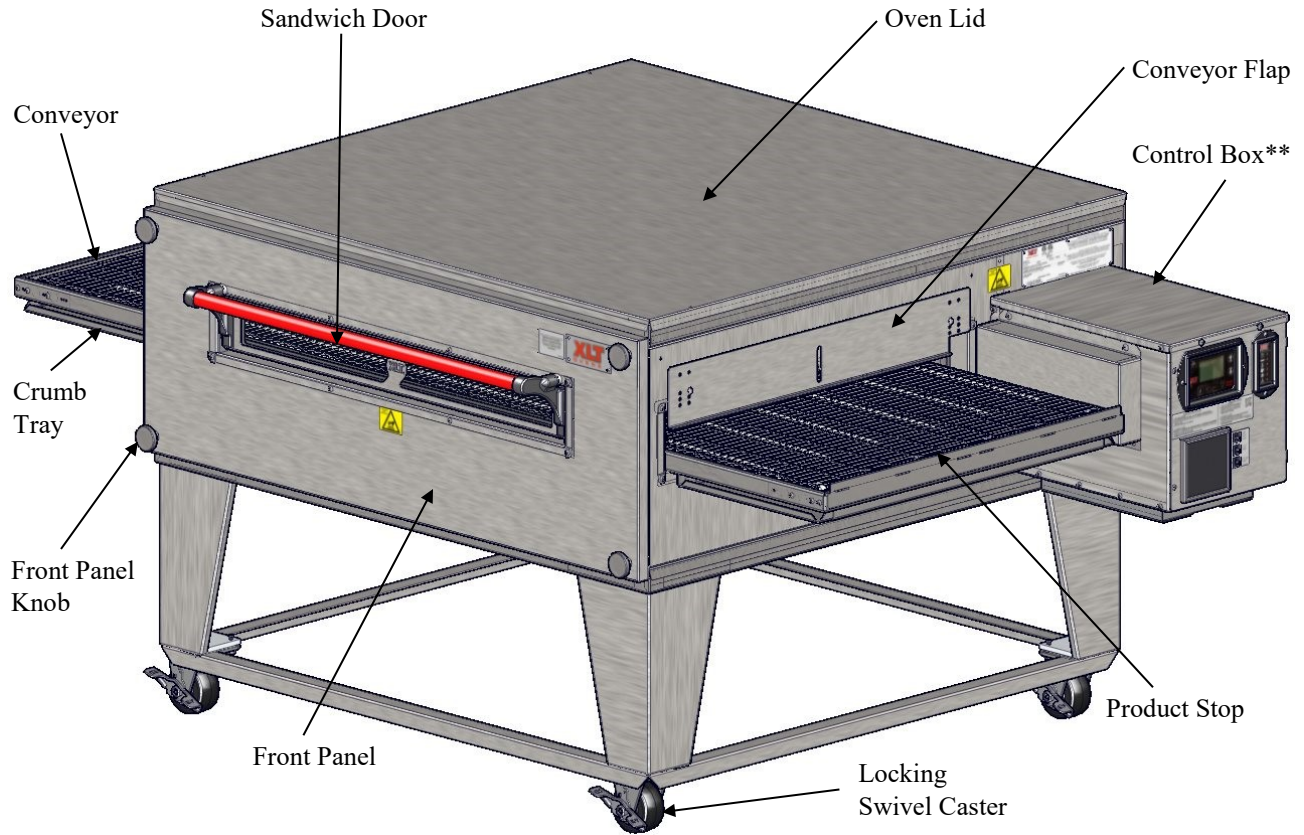

**Control box package may vary based on date of manufacture. Control package shown above for overall oven reference only. See control package options below.

Integrated Control Package

Discrete Control Package

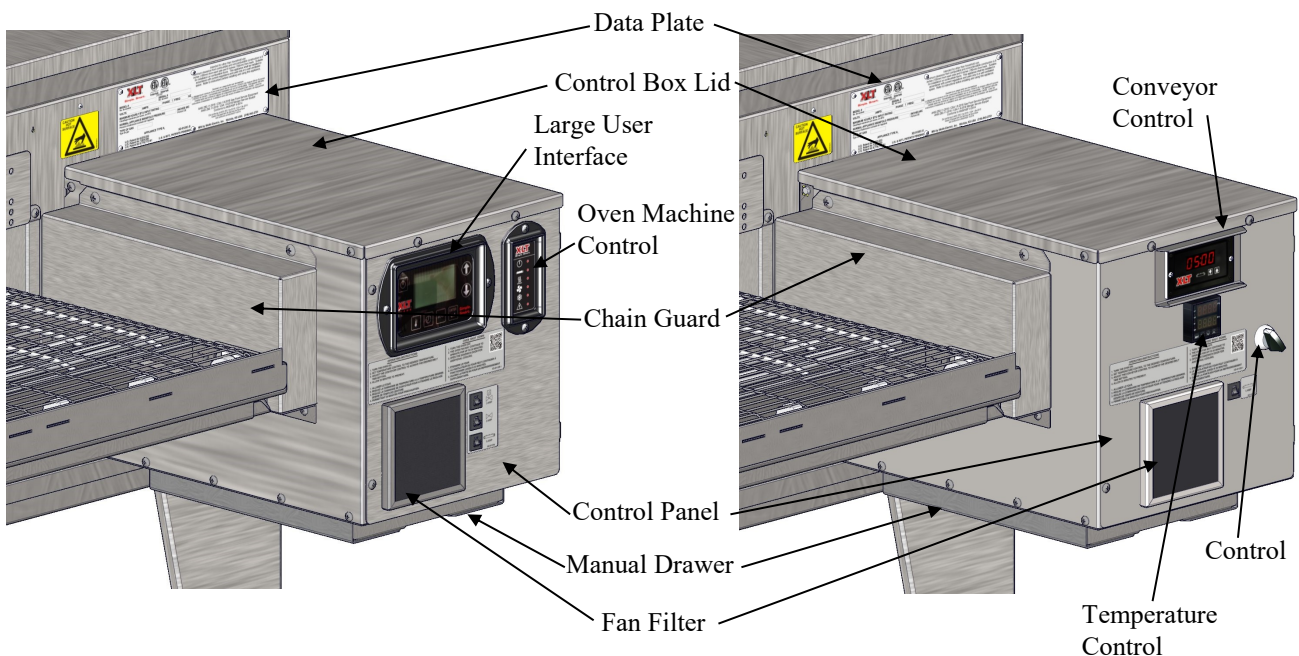

This page is intentionally left blank.

DOMESTIC WOOD CRATE PALLETS

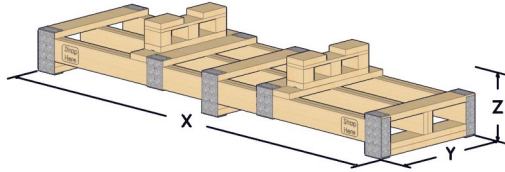

Domestic Wood Crate Dimensions				
Oven Model	Gas Oven			
	X	Y	Z	Z (With Oven)
1832	85 5/8 [2175]	31 5/8 [803]	17 4/7 [446]	60 [1526]
2336	85 5/8 [2175]	31 5/8 [803]	17 4/7 [446]	63 4/5 [1621]
2440	85 5/8 [2175]	31 5/8 [803]	17 4/7 [446]	66 [1678]
3240	85 5/8 [2175]	31 5/8 [803]	17 4/7 [446]	74 [1881]
3255	115 5/8 [2937]	31 5/8 [803]	17 1/4 [438]	73 3/4 [1873]
3855	115 5/8 [2937]	31 5/8 [803]	17 1/4 [438]	79 3/4 [2026]
4455	115 5/8 [2937]	31 5/8 [803]	17 1/4 [438]	79 3/4 [2026]
3270	115 5/8 [2937]	31 5/8 [803]	15 [381]	71 1/2 [1816]
3870	115 5/8 [2937]	31 5/8 [803]	15 [381]	77 1/2 [1969]
3280	115 5/8 [2937]	31 5/8 [803]	15 [381]	77 1/2 [1969]

Domestic Wood Crate Dimensions				
Oven Model	Gas Oven			
	X	Y	Z	Z (With Oven)
3250-DS	85 5/8 [2175]	37 5/8 [956]	15 [381]	71 1/2 [1816]
3265-DS	115 5/8 [2937]	37 5/8 [956]	15 [381]	71 1/2 [1816]
3280-DS	115 5/8 [2937]	37 5/8 [956]	15 [381]	71 1/2 [1816]
3880-DS	115 5/8 [2937]	37 5/8 [956]	15 [381]	77 1/2 [1969]

INTERNATIONAL WOODEN CRATES

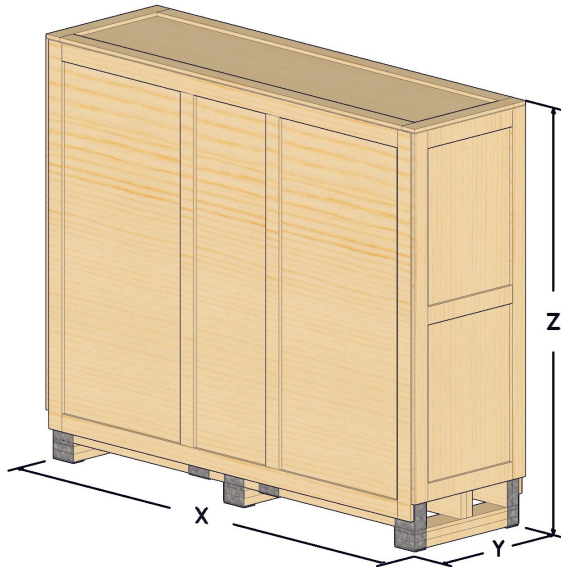

Int'l Wood Crate Dimensions			
Oven Model	Gas Oven		
	X	Y	Z
1832	76 [1930]	29 3/4 [756]	63 1/2 [1613]
2336	84 [2134]	29 3/4 [756]	69 1/2 [1765]
2440	84 [2134]	29 3/4 [756]	69 1/2 [1765]
3240	84 [2134]	29 3/4 [756]	77 1/2 [1969]
3255	99 [2515]	29 3/4 [756]	77 1/2 [1969]
3855	99 [2515]	29 3/4 [756]	83 1/2 [2121]
4455	99 [2515]	29 3/4 [756]	85 1/2 [2172]
3270	115 1/2 [2934]	29 3/4 [756]	77 1/2 [1969]
3870	115 1/2 [2934]	29 3/4 [756]	83 1/2 [2121]
3280	115 1/2 [2934]	29 3/4 [756]	83 1/2 [2121]

Int'l Wood Crate Dimensions			
Oven Model	Gas Oven		
	X	Y	Z
3250-DS	84 [2134]	35 3/4 [908]	77 1/2 [1969]
3265-DS	99 [2515]	35 3/4 [908]	77 1/2 [1969]
3280-DS	115 1/2 [2934]	35 3/4 [908]	77 1/2 [1969]
3880-DS	115 1/2 [2934]	35 3/4 [908]	83 1/2 [2121]

METAL SKIDS (Containers Only)

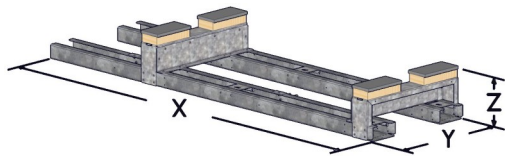

Metal Skid Dimensions				
Oven Model	Gas Oven			
	X	Y	Z	Z (With Oven)
1832	55 [1397]	21 2/3 [551]	8 5/8 [219]	51 1/8 [1299]
2336	59 [1499]	21 2/3 [551]	8 5/8 [219]	54 7/8 [1394]
2440	63 [1600]	21 2/3 [551]	8 5/8 [219]	57 1/8 [1451]
3240	63 [1600]	21 2/3 [551]	8 5/8 [219]	65 1/8 [1654]
3255	78 [1981]	21 2/3 [551]	8 5/8 [219]	65 1/8 [1654]
3855	78 [1981]	21 2/3 [551]	8 5/8 [219]	71 1/8 [1807]
4455	78 [1981]	21 2/3 [551]	8 5/8 [219]	77 1/8 [1959]
3270	115 [2921]	21 2/3 [551]	9 3/4 [248]	66 1/4 [1683]
3870	115 [2921]	21 2/3 [551]	9 3/4 [248]	72 1/4 [1835]
3280	115 [2921]	21 2/3 [551]	9 3/4 [248]	66 1/4 [1683]

Metal Skid Dimensions				
Oven Model	Gas Oven			
	X	Y	Z	Z (With Oven)
3250-DS	68 [1727]	27 2/3 [704]	8 5/8 [219]	65 1/8 [1654]
3265-DS	97 [2464]	27 2/3 [704]	8 5/8 [219]	65 1/8 [1654]
3280-DS	115 [2921]	27 2/3 [704]	9 3/4 [248]	66 1/4 [1683]
3880-DS	115 [2921]	27 2/3 [704]	9 3/4 [248]	72 1/4 [1835]

NOTE: All dimensions in inches [millimeters], ± 1/4 [6], unless otherwise noted.

OVEN DIMENSIONS & WEIGHTS

SINGLE STACK

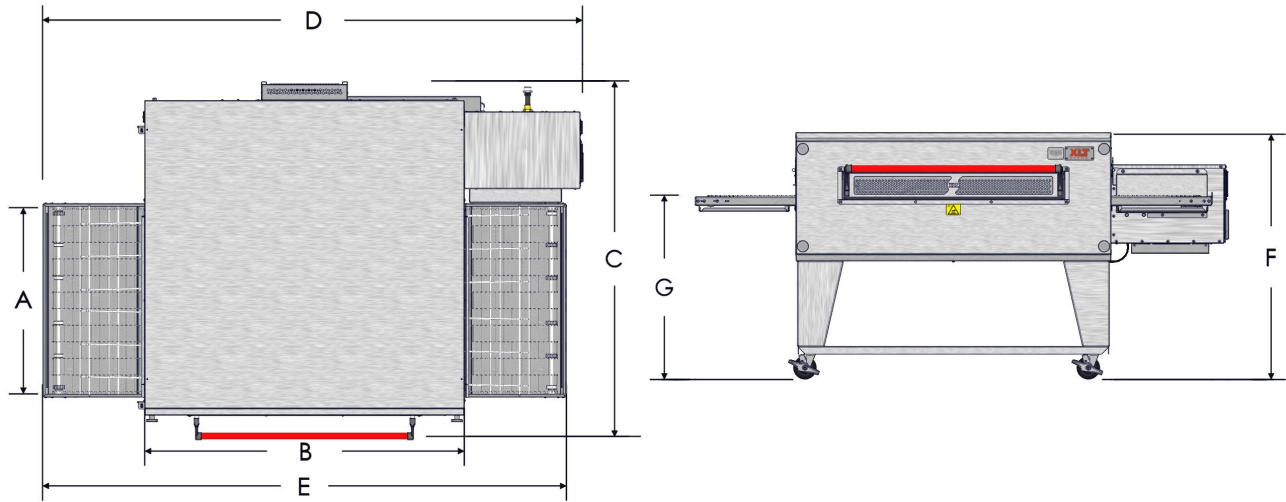

SINGLE OVEN	A	B	C	D	E	F	G	OVEN WEIGHT	CRATED WEIGHTS (1 CRATE)			
									DOM. WOOD	INTL. WOOD	METAL SKID	
1832	18 [457]	32 [813]	47 5/6 [1215]	70 1/4 [1784]	67 1/4 [1708]	43 [1092]	32 [813]	569 [258]	1832	696 [316]	747 [339]	624 [283]
2336	23 [584]	36 [914]	51 [1295]	70 1/4 [1784]	65 3/4 [1670]	43 [1092]	32 [813]	634 [288]	2336	761 [345]	826 [375]	691 [313]
2440	24 [610]	40 [1016]	53 5/6 [1367]	78 1/4 [1988]	75 1/4 [1911]	43 [1092]	32 [813]	706 [320]	2440	833 [378]	898 [407]	766 [347]
3240	32 [813]	40 [1016]	61 5/6 [1570]	78 1/4 [1988]	75 1/4 [1911]	43 [1092]	32 [813]	817 [371]	3240	944 [428]	1015 [460]	877 [398]
3255	32 [813]	55 [1397]	61 5/6 [1570]	93 1/4 [2369]	90 1/4 [2292]	43 [1092]	32 [813]	993 [450]	3255	1154 [523]	1223 [555]	1061 [481]
3855	38 [965]	55 [1397]	67 5/6 [1723]	93 1/4 [2369]	90 1/4 [2292]	43 [1092]	32 [813]	1065 [483]	3855	1226 [556]	1300 [590]	1133 [514]
4455	44 [1118]	55 [1397]	73 5/6 [1875]	93 1/4 [2369]	90 1/4 [2292]	43 [1092]	32 [813]	1131 [513]	4455	1292 [586]	1363 [618]	1199 [544]
3270-1B	32 [813]	70 [1778]	61 5/6 [1570]	108 [2743]	105 1/4 [2673]	43 [1092]	32 [813]	1169 [530]	3270-1B	1317 [597]	1413 [641]	1280 [581]
3270-2B	32 [813]	70 [1778]	61 5/6 [1570]	111 [2819]	105 1/4 [2673]	43 [1092]	32 [813]	1273 [577]	3270-2B	1421 [645]	1517 [688]	1384 [628]
3870	38 [965]	70 [1778]	67 5/6 [1723]	111 [2819]	105 1/4 [2673]	43 [1092]	32 [813]	1388 [630]	3870	1536 [697]	1638 [743]	1499 [680]
3280	32 [813]	80 [2032]	61 5/6 [1570]	110 5/8 [2810]	110 4/5 [2814]	43 [1092]	32 [813]	1369 [621]	3280	1517 [688]	1613 [732]	1480 [671]

DS MODELS

SINGLE OVEN	A	B	C	D	E	F	G	OVEN WEIGHT	CRATED WEIGHTS (1 CRATE)			
									DOM. WOOD	INTL. WOOD	METAL SKID	
3250-DS	32 [813]	50 [1270]	61 7/8 [1572]	90 1/2 [2299]	90 1/4 [2292]	48 5/8 [1235]	35 [889]	978 1/2 [444]	3250-DS	1104 [501]	1185 [538]	1044 [474]
3265-DS	32 [813]	65 [1651]	61 7/8 [1572]	105 3/4 [2686]	105 1/4 [2673]	48 5/8 [1235]	35 [889]	1258 [571]	3265-DS	1416 [642]	1499 [680]	1341 [608]
3280-DS	32 [813]	80 [2032]	61 7/8 [1572]	120 3/4 [3067]	119 7/8 [3045]	48 5/8 [1235]	35 [889]	1454 [660]	3280-DS	1612 [731]	1714 [777]	1568 [711]
3880-DS	38 [965]	80 [2032]	67 7/8 [1724]	120 3/4 [3067]	119 7/8 [3045]	48 5/8 [1235]	35 [889]	1601 1/4 [726]	3880-DS	1760 [798]	1866 [846]	1715 [778]

NOTE: All dimensions in inches [millimeters], ± 1/4 [6], unless otherwise noted.
All weights in pounds [kilograms] unless otherwise noted.

DOUBLE STACK

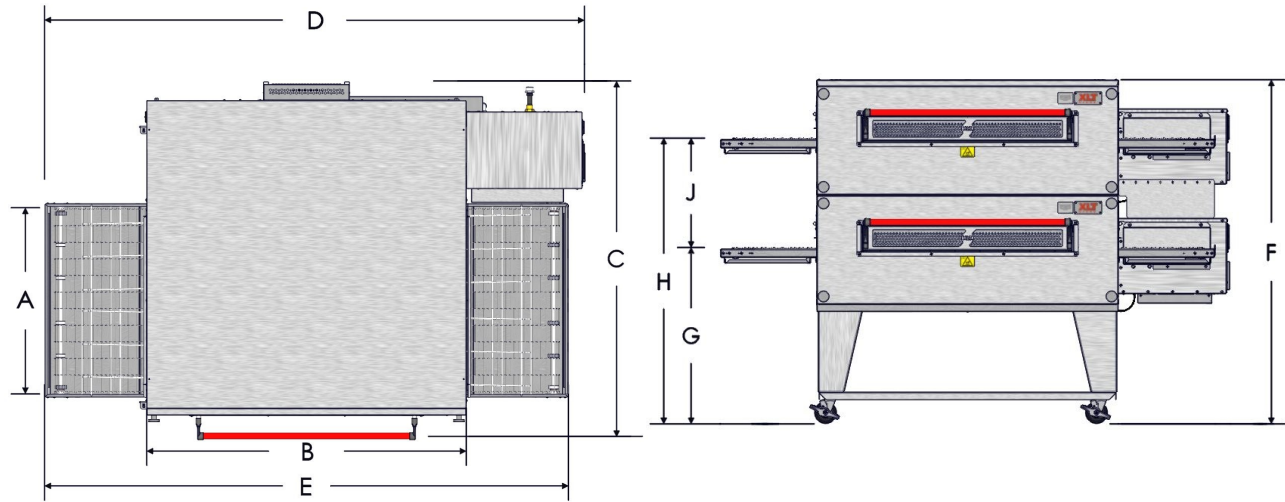

DOUBLE STACK	A	B	C	D	E	F	G	H	OVEN WEIGHT	DOUBLE OVEN	CRATED WEIGHTS (2 CRATES)		
											DOM. WOOD	INTL. WOOD	METAL SKID
1832	18 [457]	32 [813]	47 5/6 [1215]	70 1/4 [1784]	67 1/4 [1708]	63 [1600]	32 [813]	52 [1321]	1034 [469]	1832	1288 [584]	1390 [630]	1143 [518]
2336	23 [584]	36 [914]	51 [1295]	70 1/4 [1784]	65 3/4 [1670]	63 [1600]	32 [813]	52 [1321]	1151 [522]	2336	1405 [637]	1534 [696]	1265 [574]
2440	24 [610]	40 [1016]	53 5/6 [1367]	78 1/4 [1988]	75 1/4 [1911]	63 [1600]	32 [813]	52 [1321]	1286 [583]	2440	1540 [699]	1669 [757]	1405 [637]
3240	32 [813]	40 [1016]	61 5/6 [1570]	78 1/4 [1988]	75 1/4 [1911]	63 [1600]	32 [813]	52 [1321]	1483 [673]	3240	1737 [788]	1878 [852]	1602 [727]
3255	32 [813]	55 [1397]	61 5/6 [1570]	93 1/4 [2369]	90 1/4 [2292]	63 [1600]	32 [813]	52 [1321]	1800 [816]	3255	2121 [962]	2260 [1025]	1936 [878]
3855	38 [965]	55 [1397]	67 5/6 [1723]	93 1/4 [2369]	90 1/4 [2292]	63 [1600]	32 [813]	52 [1321]	1931 [876]	3855	2252 [1021]	2401 [1089]	2067 [938]
4455	44 [1118]	55 [1397]	73 5/6 [1875]	93 1/4 [2369]	90 1/4 [2292]	63 [1600]	32 [813]	52 [1321]	2047 [929]	4455	2368 [1074]	2511 [1139]	2183 [990]
3270-1B	32 [813]	70 [1778]	61 5/6 [1570]	108 [2743]	105 1/4 [2673]	63 [1600]	32 [813]	52 [1321]	2119 [961]	3270-1B	2415 [1095]	2607 [1183]	2340 [1061]
3270-2B	32 [813]	70 [1778]	61 5/6 [1570]	111 [2819]	105 1/4 [2673]	63 [1600]	32 [813]	52 [1321]	2329 [1056]	3270-2B	2625 [1191]	2817 [1278]	2550 [1157]
3870	38 [965]	70 [1778]	67 5/6 [1723]	111 [2819]	105 1/4 [2673]	63 [1600]	32 [813]	52 [1321]	2534 [1149]	3870	2830 [1284]	3033 [1376]	2755 [1250]
3280	32 [813]	80 [2032]	61 5/6 [1570]	110 5/8 [2810]	110 4/5 [2814]	63 [1600]	32 [813]	52 [1321]	2496 [1132]	3280	2792 [1266]	2984 [1354]	2717 [1232]

DS MODELS

DOUBLE STACK	A	B	C	D	E	F	G	H	OVEN WEIGHT	DOUBLE OVEN	CRATED WEIGHTS (2 CRATES)		
											DOM. WOOD	INTL. WOOD	METAL SKID
3250-DS	32 [813]	50 [1270]	61 7/8 [1572]	77 7/8 [1978]	78 [1981]	67 3/4 [1721]	28 [711]	54 [1372]	1779 [807]	3250-DS	2030 [921]	2192 [994]	1910 [866]
3265-DS	32 [813]	65 [1651]	61 7/8 [1572]	93 [2362]	93 [2362]	67 3/4 [1721]	28 [711]	54 [1372]	2303 [1045]	3265-DS	2619 [1188]	2784 [1263]	2469 [1120]
3280-DS	32 [813]	80 [2032]	61 7/8 [1572]	108 [2743]	108 [2743]	67 3/4 [1721]	28 [711]	54 [1372]	2660 [1207]	3280-DS	2976 [1350]	3179 [1442]	2887 [1310]
3880-DS	38 [965]	80 [2032]	67 7/8 [1724]	108 [2743]	108 [2743]	67 3/4 [1721]	28 [711]	54 [1372]	2925 1/2 [1327]	3880-DS	3242 [1471]	3455 [1567]	3153 [1430]

NOTE: All dimensions in inches [millimeters], ± 1/4 [6], unless otherwise noted.
All weights in pounds [kilograms] unless otherwise noted.

TRIPLE STACK

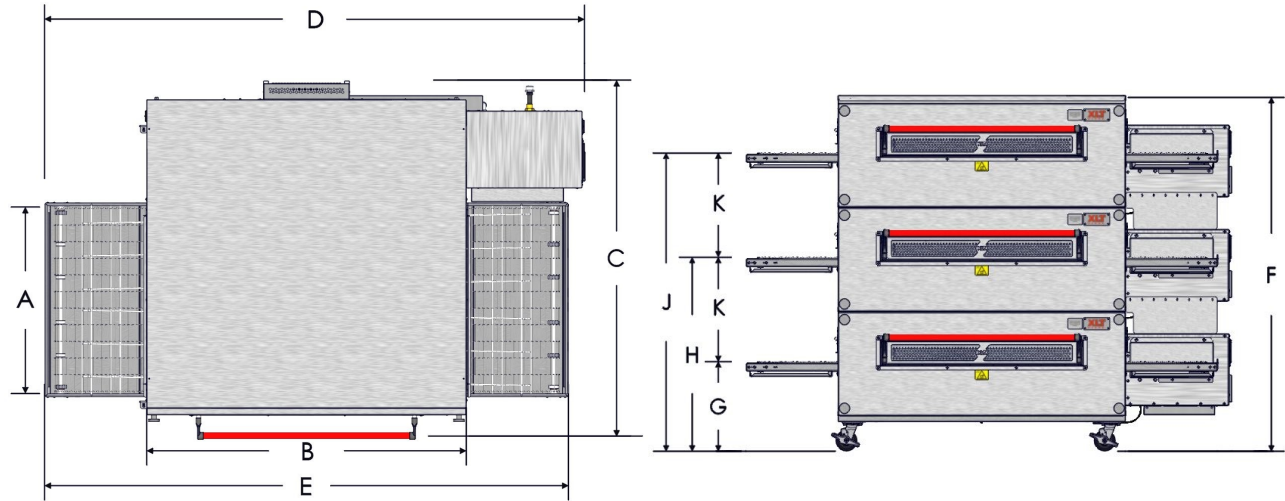

TRIPLE STACK	A	B	C	D	E	F	G	H	J	OVEN WEIGHT	TRIPLE OVEN	CRATED WEIGHTS (3 CRATES)		
												DOM. WOOD	INTL. WOOD	METAL SKID
1832	18 [457]	32 [813]	47 5/6 [1215]	70 1/4 [1784]	67 1/4 [1708]	68 [1727]	17 [432]	37 [940]	57 [1448]	1343 [609]	1832	1724 [782]	1877 [851]	1507 [684]
2336	23 [584]	36 [914]	51 [1295]	70 1/4 [1784]	65 3/4 [1670]	68 [1727]	17 [433]	37 [941]	57 [1448]	1502 [681]	2336	1883 [854]	2076 [942]	1673 [759]
2440	24 [610]	40 [1016]	53 5/6 [1367]	78 1/4 [1988]	75 1/4 [1911]	68 [1727]	17 [432]	37 [940]	57 [1448]	1707 [774]	2440	2088 [947]	2281 [1035]	1885 [855]
3240	32 [813]	40 [1016]	61 5/6 [1570]	78 1/4 [1988]	75 1/4 [1911]	68 [1727]	17 [433]	37 [941]	57 [1448]	2005 [909]	3240	2386 [1082]	2597 [1178]	2183 [990]
3255	32 [813]	55 [1397]	61 5/6 [1570]	93 1/4 [2369]	90 1/4 [2292]	68 [1727]	17 [432]	37 [940]	57 [1448]	2605 [1182]	3255	3086 [1400]	3294 [1494]	2809 [1274]
3855	38 [965]	55 [1397]	67 5/6 [1723]	93 1/4 [2369]	90 1/4 [2292]	68 [1727]	17 [433]	37 [941]	57 [1448]	2994 [1358]	3855	3475 [1576]	3698 [1677]	3198 [1451]
4455	44 [1118]	55 [1397]	73 5/6 [1875]	93 1/4 [2369]	90 1/4 [2292]	68 [1727]	17 [432]	37 [940]	57 [1448]	3146 [1427]	4455	3627 [1645]	3842 [1743]	3350 [1520]
3270-1B	32 [813]	70 [1778]	61 5/6 [1570]	108 [2743]	105 1/4 [2673]	68 [1727]	17 [433]	37 [941]	57 [1448]	3064 [1390]	3270-1B	3508 [1591]	3796 [1722]	3395 [1540]
3270-2B	32 [813]	70 [1778]	61 5/6 [1570]	111 [2819]	105 1/4 [2673]	68 [1727]	17 [432]	37 [940]	57 [1448]	3559 [1614]	3270-2B	4003 [1816]	4291 [1946]	3890 [1764]
3870	38 [965]	70 [1778]	67 5/6 [1723]	111 [2819]	105 1/4 [2673]	68 [1727]	17 [433]	37 [941]	57 [1448]	3801 [1724]	3870	4245 [1925]	4549 [2063]	4132 [1874]
3280	32 [813]	80 [2032]	61 5/6 [1570]	110 5/8 [2810]	110 4/5 [2814]	68 [1727]	17 [432]	37 [940]	57 [1448]	3789 [1719]	3280	4233 [1920]	4521 [2051]	4120 [1869]

NOTE: All dimensions in inches [millimeters], ± 1/4 [6], unless otherwise noted.
All weights in pounds [kilograms] unless otherwise noted.

SINGLE STACK

GAS AND ELECTRICAL INLET DIMENSIONS WORLD (230V / 50 Hz)

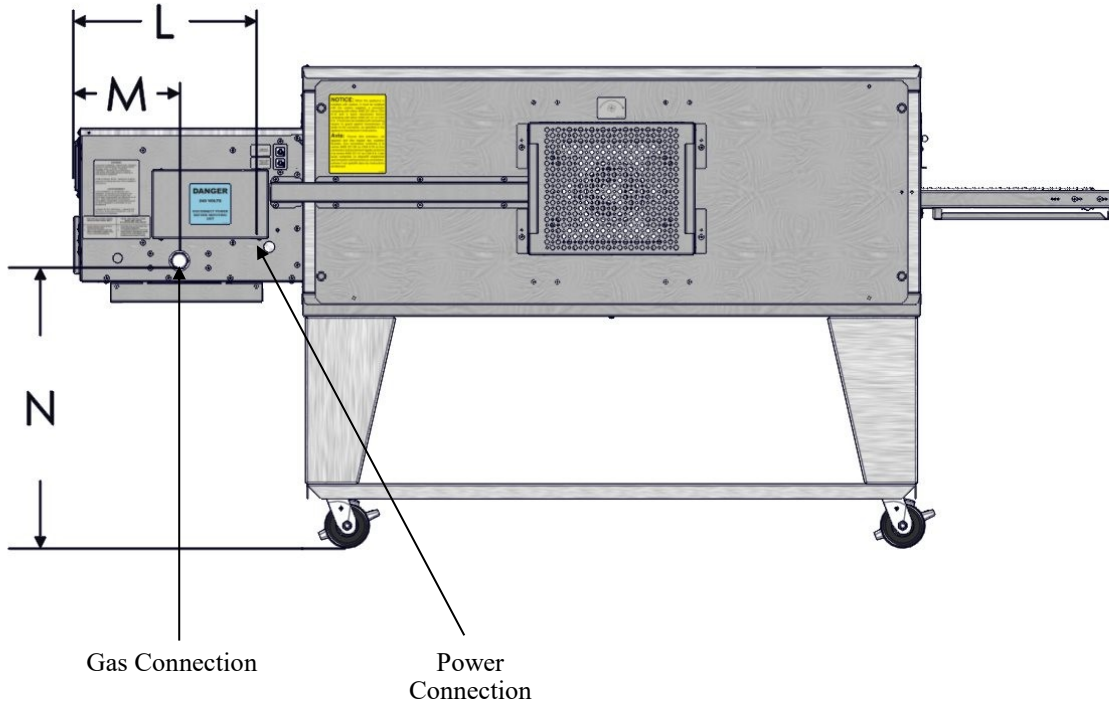

SINGLE OVEN	L	M	N	OVEN WEIGHT
1832	18 1/4 [464]	9 3/8 [238]	25 1/2 [648]	576 [261]
2336	18 1/4 [464]	9 3/8 [238]	25 1/2 [648]	641 [291]
2440	18 1/4 [464]	9 3/8 [238]	25 1/2 [648]	713 [323]
3240	16 1/8 [410]	9 3/8 [238]	25 1/2 [648]	832 [377]
3255	16 1/8 [410]	9 3/8 [238]	25 1/2 [648]	1002 [454]
3855	16 1/8 [410]	9 3/8 [238]	25 1/2 [648]	1072 [486]
4455	16 1/8 [410]	9 3/8 [238]	25 1/2 [648]	1140 [517]
3270-1B	16 1/8 [410]	9 3/8 [238]	25 1/2 [648]	1178 [534]
3270-2B	16 1/8 [410]	9 3/8 [238]	25 1/2 [648]	1286 [583]
3870	16 1/8 [410]	9 3/8 [238]	25 1/2 [648]	1398 [634]
3280	16 1/8 [410]	9 3/8 [238]	25 1/2 [648]	1383 [627]

SINGLE OVEN	CRATED WEIGHTS (1 CRATE)		
	DOM. WOOD	INTL. WOOD	METAL SKID
1832	703 [319]	754 [342]	631 [286]
2336	768 [348]	833 [378]	698 [317]
2440	840 [381]	905 [411]	773 [351]
3240	959 [435]	1030 [467]	892 [405]
3255	1163 [528]	1232 [559]	1070 [485]
3855	1233 [559]	1307 [593]	1140 [517]
4455	1301 [590]	1372 [622]	1208 [548]
3270-1B	1326 [601]	1422 [645]	1289 [585]
3270-2B	1434 [650]	1530 [694]	1397 [634]
3870	1546 [701]	1648 [748]	1509 [684]
3280	1531 [694]	1627 [738]	1494 [678]

DS MODELS

SINGLE OVEN	CRATED WEIGHTS (1 CRATE)		
	DOM. WOOD	INTL. WOOD	METAL SKID
3250-DS	1104 [501]	1185 [538]	1044 [474]
3265-DS	1416 [642]	1499 [680]	1341 [608]
3280-DS	1612 [731]	1714 [777]	1568 [711]
3880-DS	1760 [798]	1866 [846]	1715 [778]

NOTE: All dimensions in inches [millimeters], ± 1/4 [6], unless otherwise noted.
All weights in pounds [kilograms] unless otherwise noted.

OVEN REQUIREMENTS

DOUBLE STACK

GAS AND ELECTRICAL INLET DIMENSIONS WORLD (230V / 50 Hz)

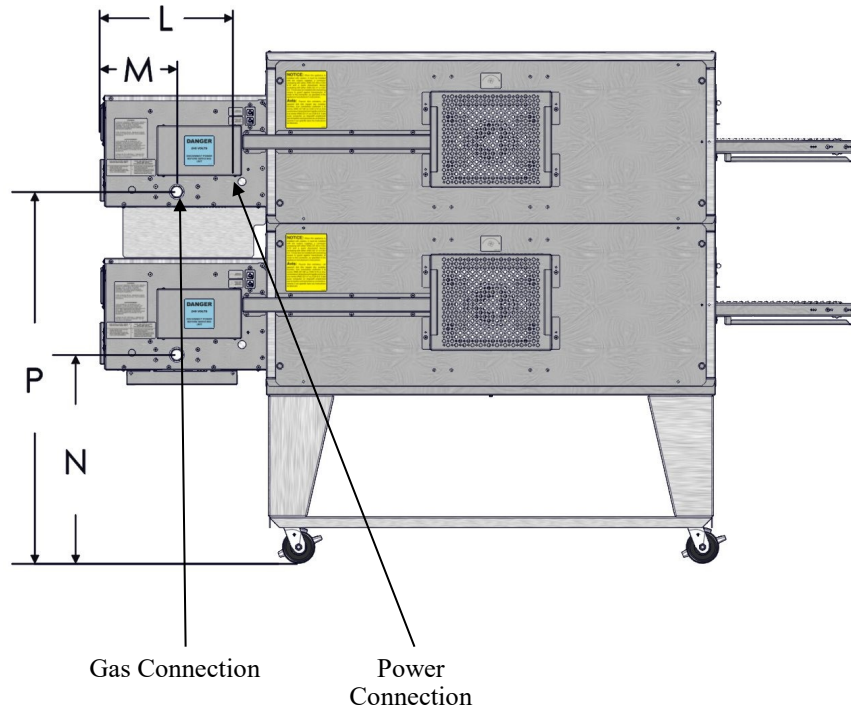

DOUBLE STACK	L	M	N	P	OVEN WEIGHT
1832	18 1/4 [464]	9 3/8 [238]	25 1/2 [648]	45 1/2 [1156]	1000 [454]
2336	18 1/4 [464]	9 3/8 [238]	25 1/2 [648]	45 1/2 [1156]	1115 [506]
2440	18 1/4 [464]	9 3/8 [238]	25 1/2 [648]	45 1/2 [1156]	1243 [564]
3240	16 1/8 [410]	9 3/8 [238]	25 1/2 [648]	45 1/2 [1156]	1444 [655]
3255	16 1/8 [410]	9 3/8 [238]	25 1/2 [648]	45 1/2 [1156]	1751 [794]
3855	16 1/8 [410]	9 3/8 [238]	25 1/2 [648]	45 1/2 [1156]	1872 [849]
4455	16 1/8 [410]	9 3/8 [238]	25 1/2 [648]	45 1/2 [1156]	1980 [898]
3270-1B	16 1/8 [410]	9 3/8 [238]	25 1/2 [648]	45 1/2 [1156]	2070 [939]
3270-2B	16 1/8 [410]	9 3/8 [238]	25 1/2 [648]	45 1/2 [1156]	2277 [1033]
3870	16 1/8 [410]	9 3/8 [238]	25 1/2 [648]	45 1/2 [1156]	2466 [1119]
3280	16 1/8 [410]	9 3/8 [238]	25 1/2 [648]	45 1/2 [1156]	2444 [1109]

DOUBLE OVEN	CRATED WEIGHTS (2 CRATES)		
	DOM. WOOD	INTL. WOOD	METAL SKID
1832	1254 [569]	1356 [615]	1109 [503]
2336	1369 [621]	1498 [679]	1229 [557]
2440	1497 [679]	1626 [738]	1362 [618]
3240	1698 [770]	1839 [834]	1563 [709]
3255	2072 [940]	2211 [1003]	1887 [856]
3855	2193 [995]	2342 [1062]	2008 [911]
4455	2301 [1044]	2444 [1109]	2116 [960]
3270-1B	2366 [1073]	2558 [1160]	2291 [1039]
3270-2B	2573 [1167]	2765 [1254]	2498 [1133]
3870	2762 [1253]	2965 [1345]	2687 [1219]
3280	2740 [1243]	2932 [1330]	2665 [1209]

DS MODELS

DOUBLE OVEN	CRATED WEIGHTS (2 CRATES)		
	DOM. WOOD	INTL. WOOD	METAL SKID
3250-DS	2030 [921]	2192 [994]	1910 [866]
3265-DS	2619 [1188]	2784 [1263]	2469 [1120]
3280-DS	2976 [1350]	3179 [1442]	2887 [1310]
3880-DS	3242 [1471]	3455 [1567]	3153 [1430]

NOTE: All dimensions in inches [millimeters], ± 1/4 [6], unless otherwise noted.
All weights in pounds [kilograms] unless otherwise noted.

TRIPLE STACK

GAS AND ELECTRICAL INLET DIMENSIONS WORLD (230V / 50 Hz)

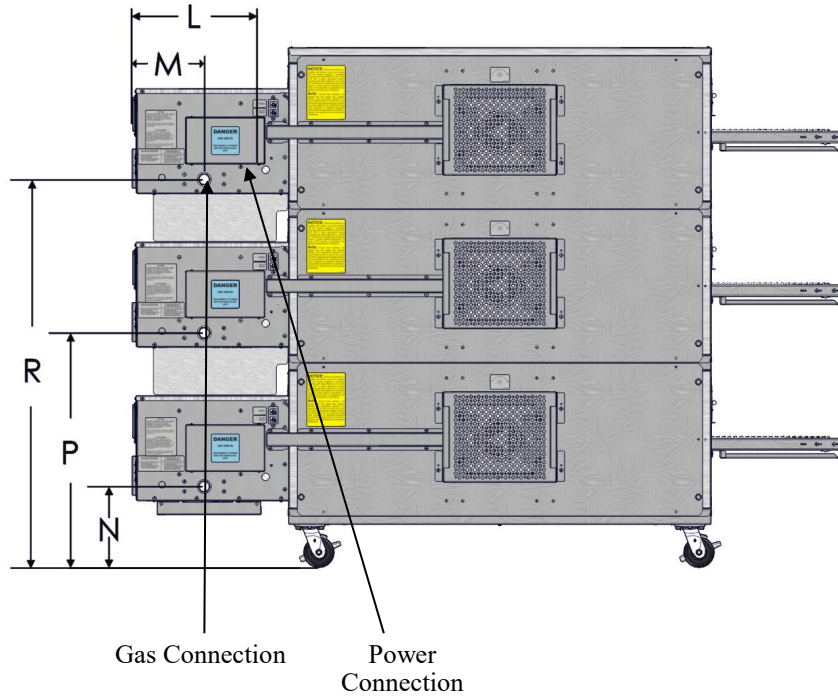

TRIPLE STACK	L	M	N	P	R	OVEN WEIGHT
1832	18 1/4 [464]	9 1/2 [241]	10 1/2 [267]	30 1/2 [775]	50 1/2 [1283]	1363 [618]
2336	18 1/4 [464]	9 1/2 [241]	10 1/2 [267]	30 1/2 [775]	50 1/2 [1283]	1523 [691]
2440	18 1/4 [464]	9 1/2 [241]	10 1/2 [267]	30 1/2 [775]	50 1/2 [1283]	1727 [783]
3240	16 1/8 [410]	9 3/8 [238]	10 1/2 [267]	30 1/2 [775]	50 1/2 [1283]	2048 [929]
3255	16 1/8 [410]	9 3/8 [238]	10 1/2 [267]	30 1/2 [775]	50 1/2 [1283]	2631 [1193]
3855	16 1/8 [410]	9 3/8 [238]	10 1/2 [267]	30 1/2 [775]	50 1/2 [1283]	3021 [1370]
4455	16 1/8 [410]	9 3/8 [238]	10 1/2 [267]	30 1/2 [775]	50 1/2 [1283]	3175 [1440]
3270-1B	16 1/8 [410]	9 3/8 [238]	10 1/2 [267]	30 1/2 [775]	50 1/2 [1283]	3091 [1402]
3270-2B	16 1/8 [410]	9 3/8 [238]	10 1/2 [267]	30 1/2 [775]	50 1/2 [1283]	3599 [1632]
3870	16 1/8 [410]	9 3/8 [238]	10 1/2 [267]	30 1/2 [775]	50 1/2 [1283]	3831 [1738]
3280	16 1/8 [410]	9 3/8 [238]	10 1/2 [267]	30 1/2 [775]	50 1/2 [1283]	3829 [1737]

TRIPLE OVEN	CRATED WEIGHTS (3 CRATES)		
	DOM. WOOD	INTL. WOOD	METAL SKID
1832	3105 [1408]	3203 [1453]	2967 [1346]
2336	3441 [1561]	3564 [1617]	3307 [1500]
2440	3869 [1755]	3992 [1811]	3740 [1696]
3240	4543 [2061]	4678 [2122]	4414 [2002]
3255	5832 [2645]	5964 [2705]	5655 [2565]
3855	6651 [3017]	6793 [3081]	6474 [2937]
4455	6974 [3163]	7111 [3225]	6797 [3083]
3270-1B	6774 [3073]	6957 [3156]	6702 [3040]
3270-2B	7841 [3557]	8024 [3640]	7769 [3524]
3870	8328 [3778]	8522 [3866]	8256 [3745]
3280	8324 [3776]	8507 [3859]	8252 [3743]

NOTE: All dimensions in inches [millimeters], ± 1/4 [6], unless otherwise noted.
All weights in pounds [kilograms] unless otherwise noted.

OVEN REQUIREMENTS

All values shown on this page are per each oven

Standard (120V/60Hz) - Gas Oven Heating Values & Orifice Sizes						
Oven Model	Heating Values		Orifice Sizes			
	All Fuels		NAT		LP	
	BTU/HR		Inches	MM	Inches	MM
1832	56,000		0.136	3.45	0.084	2.13
2336	71,000		0.152	3.86	0.098	2.49
2440	71,000		0.152	3.86	0.098	2.49
3240	125,000		0.196	4.98	0.125	3.18
3255	140,000		0.209	5.31	0.130	3.30
3855	140,000		0.218	5.54	0.134	3.40
4455	170,000		0.234	5.94	0.140	3.56
3270-1B	150,000		0.218	5.54	0.134	3.40
3270-2B	209,000		0.187	4.75	0.113	2.87
3870	209,000		0.187	4.75	0.113	2.87
3280	235,000		0.196	4.98	0.123	3.12
3250-DS	140,000		0.218	5.54	0.134	3.40
3265-DS	209,000		0.187	4.75	0.113	2.87
3280-DS	235,000		0.196	4.98	0.123	3.12
3880-DS	235,000		0.196	4.98	0.123	3.12



NOTE

The BTU readings listed are maximums that could be reached while climbing to the set point temperature. Once set point is reached the BTU/HR will lower. Readings will vary as oven capacity changes during operation.

World (230V/50Hz) - Gas Oven Heating Values & Orifice Sizes								
Oven Model	Heating Values						Orifice Sizes	
	Natural		Butane	Propane		NAT	LP	
	G20		G30	G31				
	KW/HR	MJ/HR	KW/HR	KW/HR	KW/HR	MJ/HR	MM	MM
1832	16.41	59.08	13.18	18.50	16.41	59.08	3.45	2.13
2336	20.80	74.91	16.99	25.00	20.80	74.91	3.86	2.49
2440	20.80	74.91	16.99	25.00	20.80	74.91	3.86	2.49
3240	36.60	131.88	28.00	39.50	36.60	131.88	4.98	3.18
3255	41.00	147.71	33.00	43.00	41.00	147.71	5.31	3.30
3855	41.03	147.71	33.70	44.54	41.03	147.71	5.54	3.40
4455	49.80	179.36	40.00	52.00	49.80	179.36	5.94	3.56
3270-1B	43.90	158.26	37.00	43.90	45.40	163.44	5.54	3.40
3270-2B	61.25	220.51	51.28	65.94	61.25	220.51	4.75	2.87
3870	61.25	220.51	51.28	65.94	61.25	220.51	4.75	2.87
3280	68.87	247.93	55.68	73.85	68.87	247.93	4.98	3.12
3250-DS	41.03	147.71	33.70	44.54	41.03	147.71	5.54	3.40
3265-DS	61.25	220.51	51.28	65.94	61.25	220.51	4.75	2.87
3280-DS	68.87	247.93	55.68	73.85	68.87	247.93	4.98	3.12
3880-DS	68.87	247.93	55.68	73.85	68.87	247.93	4.98	3.12

All values shown on this page are per each oven

Korea (220V/60Hz) - Gas Oven Heating Values & Orifice Sizes				
Oven Model	Heating Values		Orifice Sizes	
	NAT	LP	NAT	LP
	KW/HR	KW/HR	MM	MM
1832	16.41	16.41	3.45	2.13
2336	20.80	20.80	3.86	2.49
2440	20.80	20.80	3.86	2.49
3240	36.60	36.60	4.98	3.18
3255	41.00	41.00	5.31	3.30
3855	41.03	41.03	5.54	3.40
4455	49.80	49.80	5.94	3.56
3270-1B	43.90	45.40	5.54	3.40
3270-2B	61.25	61.25	4.75	2.87
3870	61.25	61.25	4.75	2.87
3280	68.87	68.87	4.98	3.12
3250-DS	41.03	41.03	5.54	3.40
3265-DS	61.25	61.25	4.75	2.87
3280-DS	68.87	68.87	4.98	3.12
3880-DS	68.87	68.87	4.98	3.12

Australia & New Zealand (230V/50Hz) - Gas Oven Heating Values & Orifice Sizes						
Oven Model	Heating Values				Orifice Sizes	
	NAT		LP		NAT	LP
	KW/HR	MJ/HR	KW/HR	MJ/HR	MM	MM
1832	16.41	59.08	16.41	59.08	3.45	2.13
2336	20.80	74.91	20.80	74.91	3.86	2.49
2440	20.80	74.91	20.80	74.91	3.86	2.49
3240	36.60	131.88	36.60	131.88	4.98	3.18
3255	41.00	147.71	41.00	147.71	5.31	3.30
3855	41.03	147.71	41.03	147.71	5.54	3.40
4455	49.80	179.36	49.80	179.36	5.94	3.56
3270-1B	43.90	158.26	45.40	163.44	5.54	3.40
3270-2B	61.25	220.51	61.25	220.51	4.75	2.87
3870	61.25	220.51	61.25	220.51	4.75	2.87
3280	68.87	247.93	68.87	247.93	4.98	3.12
3250-DS	41.03	147.71	41.03	147.71	5.54	3.40
3265-DS	61.25	220.51	61.25	220.51	4.75	2.87
3280-DS	68.87	247.93	68.87	247.93	4.98	3.12
3880-DS	68.87	247.93	68.87	247.93	4.98	3.12

Gas Oven Fuel Pressure Requirements														
Oven Models	Inlet Pressure Range								Manifold Pressure					
	Standard, World, Australia and New Zealand						Korea		Natural Gas			LP Gas		
	Natural Gas			LP Gas			Natural Gas	LP Gas	Natural Gas		LP Gas			
	W/C	mbar	kPa	W/C	mbar	kPa	kPa	kPa	W/C	mbar	kPa	W/C	mbar	kPa
All	6-14	15-35	1.50-3.50	11-14	27.5-35	2.75-3.50	1.50-2.50	2.30-3.30	3.5	8.75	0.875	10	25	2.5

Adjustable Bypass Low Flame Pressure Setting	
Gas Types	in. W/C
Natural	0.4
Propane	0.8

	Oven Gas Group								
	Natural Gas					Propane Gas			
Gas Group	I _{2H}	I _{2E}	I _{2ELL}	I _{2E+}	I _{2L}	I ₃₊	I _{3B/P} (30)	I _{3P} (30/37/50)	I _{3B} (37)
Inlet pressure (mbar)	20	20	20/25	20/25	25	28/30/37/50	28-30/37/50	30/37/50	37
Number of injectors	(1) per burner								
Main burner opening size	Fixed								
Ignition	Electric Direct Spark Igniter								
Inlet connection	Standard: 3/4" NPT					World/Korean: BSP 3/4" Male thread			

Gas Matrix by Country									
Country	Symbol	Natural Gas (8.75 mbar manifold)					LP Gas (25 mbar manifold)		
		I _{2H}	I _{2E}	I _{2ELL}	I _{2E+}	I _{2L}	I ₃₊	I _{3B/P}	I _{3P}
Austria	AT	X						X	
Belgium	BE				X		X		
Bulgaria	BG	X						X	
Croatia	HR	X						X	X
Cyprus	CY						X	X	X
Czech Republic	CZ	X					X	X	X
Denmark	DK	X						X	
Estonia	EE	X					X	X	
Finland	FI	X						X	X
France	FR				X		X	X	X
Germany	DE		X	X				X	X
Greece	GR	X					X		X
Hungary	HU	X				X		X	X
Iceland	IS	X							
Ireland	IE	X					X		X
Italy	IT	X					X		
Latvia	LT	X					X	X	
Lithuania	LV	X					X	X	
Luxembourg	LU		X				X	X	X
Malta	MT							X	X
Netherlands	NL		X			X		X	X
Norway	NO	X						X	
Poland	PL		X					X	X
Portugal	PT	X					X		X
Romania	RO	X					X		
Slovakia	SK	X					X	X	X
Slovenia	SI	X						X	X
Spain	ES	X					X		X
Sweden	SE	X						X	
Switzerland	CH	X					X	X	X
Turkey	TR	X						X	X
United Kingdom	GB	X					X		X

Gas Supply Requirements for All Ovens



All installations must conform to local building & mechanical codes.

NOTE

1. The gas supply shall have a gas meter and regulator large enough to handle **ALL** of the gas appliances, such as the furnace, water heater, & ovens in operation at the same time. Add up all of the Btu/kw/MJ ratings to determine the total load.
2. The gas supply shall have a separate gas meter and gas pressure regulator for each occupant. Installations in multiple occupancy buildings, (strip malls) shall not share gas meters and regulators with other occupants.
3. Gas hose assemblies with quick disconnects for each oven deck will be installed at each valve. The quick disconnect will connect at the oven side while the threaded end will connect at the shutoff valve.
4. A sediment trap shall be installed downstream of the equipment shutoff valve as close to the inlet of the appliance as practical at the time of appliance installation. The sediment trap shall be a tee fitting with a capped nipple in the bottom outlet as illustrated (Pg. 26), and in accordance with ANSI Z223.1-2012 and NFPA 54-2012 National Fuel Gas Code, section 9.6.7.
5. A sediment trap shall be installed on the rear of the oven control box before the gas hose. The sediment trap shall be a tee fitting with a capped nipple in the bottom outlet as illustrated (Pg. 26), and in accordance with ANSI Z223.1-2012 and NFPA 54-2012 National Fuel Gas Code, section 9.6.7.
6. The composition of gases varies greatly from time to time and from place to place. For this reason, the material used for the gas lines shall be steel or malleable iron, not copper. ANSI Z83.11-2016 CSA 1.8-2016 Gas Food Service Equipment states: "Copper tubing or semi rigid tubing with internal copper layering, whether internally tinned or not, shall not be used for conveying gases." ANSI Z223.1 NFPA 54 National Fuel Gas Code states: "Copper and brass tubing shall not be used if the gas contains more than an average of 0.3 grains of hydrogen sulfide per 100 scf of gas (0,7 mg/100L)."



Do not use Teflon tape on gas line connections as this can cause gas valve malfunction or plugging of orifices from shreds of tape. The use of Teflon tape could void your warranty. Contact XLT at 888-443-2751 with any questions.

- A minimum of a 1 1/2" supply line is required.

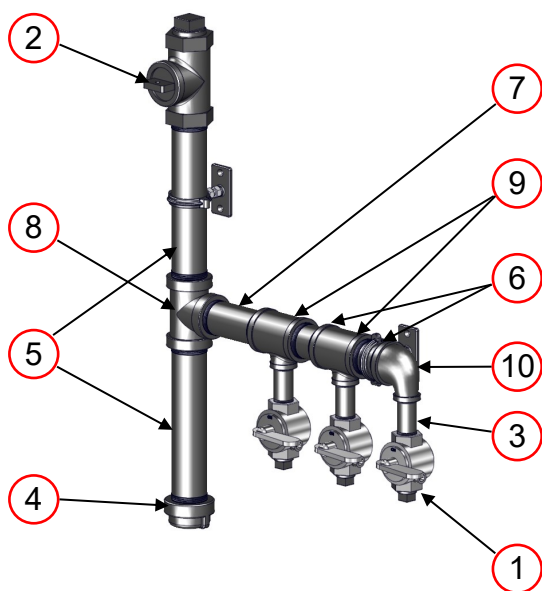

Item#	Description	QTY
1	3/4 Manual Gas Valve	3
2	1-1/2 Ball Valve	1
3	3/4 x 3 Nipple	3
4	1-1/2 Pipe Cap	1
5	1-1/2 x 10 Nipple	2
6	1-1/2 x 3 Nipple	2
7	1-1/2 x 5 Nipple	1
8	1-1/2 Tee	1
9	2-1/2 x 3/4 x 1-1/2 Reducing Tee	2
10	1-1/2 x 3/4 Reducing Elbow	1

Gas Supply Testing Requirements

1. The appliance and its individual shutoff valve must be disconnected from the gas supply piping system during any pressure testing of that system at test pressures in excess of 3.5 kPa or 1/2-psi.
2. The appliance must be isolated from the gas supply piping system by closing its individual manual shutoff valve during any pressure testing of the gas supply piping system at test pressures equal to or less than 3.45 kPa or 1/2-psi.

Gas Hose Requirements

1. For Australia, if installing with a flexible hose assembly, the assembly must be certified to AS/NZS 1869, & be Class B or D.
2. For Standard Ovens, if installing with a flexible gas hose, the installation must comply with either ANSI Z21.69 or CAN/CGA-6.16 & a disconnect device complying with either ANSI Z21.41 or CAN-6.9.
3. The installation must conform with local building codes, or in the absence of local codes, with the National Fuel Gas Code, ANSI Z223.1, latest version, Natural Gas Installation Code, CAN/CGA-B149.1, or the Liquid Petroleum Gas Installation Code, CAN/CGA-B149.2, as applicable.

All values shown this page are per each oven

Gas Oven Electrical Requirements								
Per EACH Oven								
Oven Model	Standard			Australia & World			Korea	
	Volts AC	Amps	Hertz	Volts AC	Amps	Hertz	Volts AC	Watts
1832	120 VAC 1Φ	4.8	50/60	220/230/ 240 VAC 1Φ	3	50/60	220 VAC 1Φ	660
2336								
2440								
3240								
3255								
3855								
4455								
3270-1B								
3270-2B								
3870								
3280								
3250-DS								
3265-DS								
3280-DS								
3880-DS								
				Install in accordance with AS/NZS 3000 Wiring				

FOR EACH OVEN:

- A separate 20A circuit breaker must be provided for each oven deck.
- Electrical connections must be accessible when the ovens are in the installed position.
- Electrical connections must meet all local code requirements.

Electrical Grounding Instructions

Standard Ovens

- This appliance is equipped with a three-prong (grounding) plug for your protection against shock hazard & should be plugged into a properly grounded three-prong receptacle. Do not cut or remove the grounding prong from this plug.
- When installed, the appliance must be electrically grounded in accordance with local codes, or in the absence of local codes, with the National Electrical Code, ANSI/NFPA 70, or the Canadian Electrical Code, CSA C22.2, as applicable.

World Ovens

- This appliance is equipped with a ground lug for your protection against shock hazard & must be properly grounded.
- When installed, the appliance must be electrically grounded in accordance with local codes.

Australia/New Zealand Ovens

- This appliance is equipped with a ground lug for your protection against shock hazard & must be properly grounded.
- The electrical service must be installed in accordance with AS/NZS 3000 Wiring Rules. local codes.



**HIGH
VOLTAGE**

1832, 2336 and 2440 MODELS

These ovens are suitable for installation on either combustible or non-combustible floors, and adjacent to either combustible or non-combustible walls. The motor cover is designed to provide the proper clearance to the back of the oven. The minimum side clearances are 6in./150mm, measured from the ends of the conveyor.

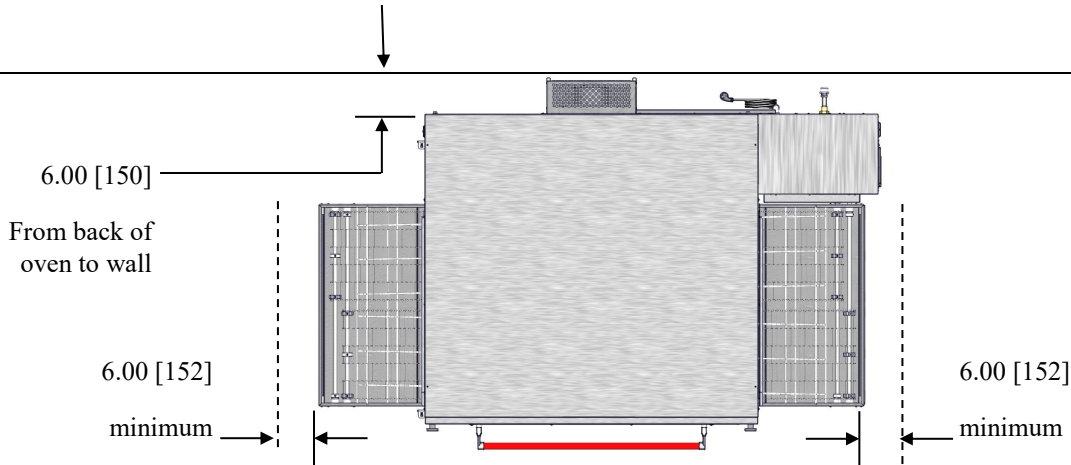

ALL OTHER MODELS

These ovens are suitable for installation on either combustible or non-combustible floors, and adjacent to either combustible or non-combustible walls. The motor cover is designed to provide the proper clearance to the back of the oven. The minimum side clearances are 6in./152mm measured from the ends of the conveyor.

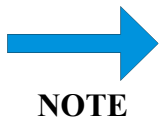
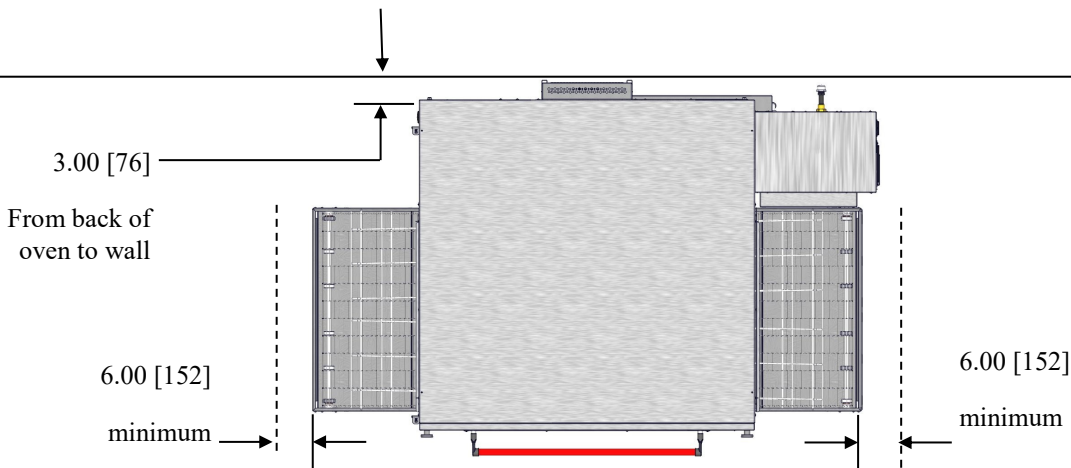

All installations must conform to local building and mechanical codes. It is required that the ovens be placed under a ventilation hood to provide exhaust ventilation and adequate air supply.

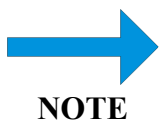

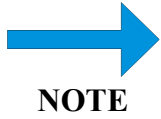

Equipment must be installed with cord anchorage to relieve strain on conductors, twisting of terminals, and abrasions to insulation.

NOTE: All dimensions in inches [millimeters], $\pm 1/4$ [6], unless otherwise noted.

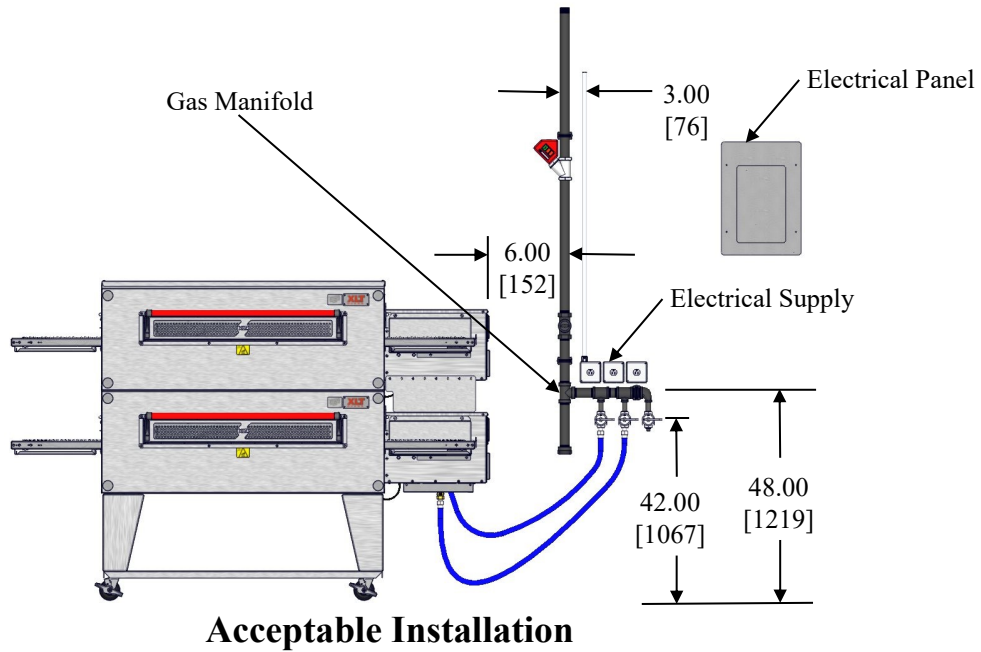

Incoming gas line MUST go beside the oven on the control box side.





CAUTION Utilities must be easily accessible when the ovens are in the installed position. Do not install utilities behind the ovens.

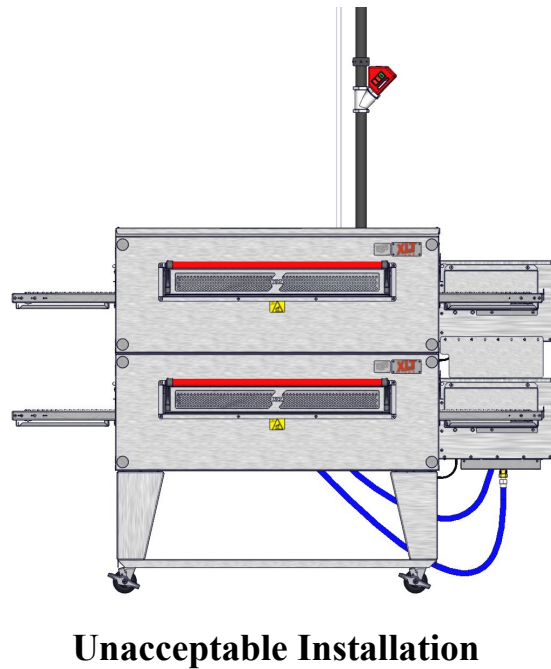

NOTE: All dimensions in inches [millimeters], ± 1/4 [6], unless otherwise noted.

This page is intentionally left blank.

WARNING & SAFETY INFORMATION

XLT ovens can easily be moved and stacked with the proper lifting equipment. The use of XLT approved lifting equipment is highly recommended. Contact XLT for more information.

**DANGER**

- These ovens are heavy & can tip or fall causing bodily injury.
- NEVER place any part of your body beneath any oven that is suspended by the lifting jacks. A crush hazard exists if the oven falls or slips.
- DO NOT place your hands on the lifting jack vertical pole beneath the jack's winch. As the jack's winch descends when you turn the jack handle, a pinch point is created between the winch & the pole.

**CAUTION**

BE CAREFUL when rolling the oven on the cart, especially when going up or down ramps & over bumps. Leave the straps/banding on until the oven is near the assembly area.

**DANGER**

- Make sure that the notch on tube of the winch assembly is aligned with the pin in the tripod base as shown on next view pages. These alignments are important and keep the jack aligned properly.
- Check for smooth operation. The cable should not be pinched and should pass smoothly over the pulley on top of the pole assembly.
- Inspect cable prior to each use.
- If cable is frayed or shows signs of excessive wear and tear, DO NOT USE until cable is replaced.
- At a minimum replace the cable annually with wire rope that meets or exceeds the jack manufacturer's specifications.
- Do not exceed the stated capacity of the jack.

Base Assembly - Single & Double Stack

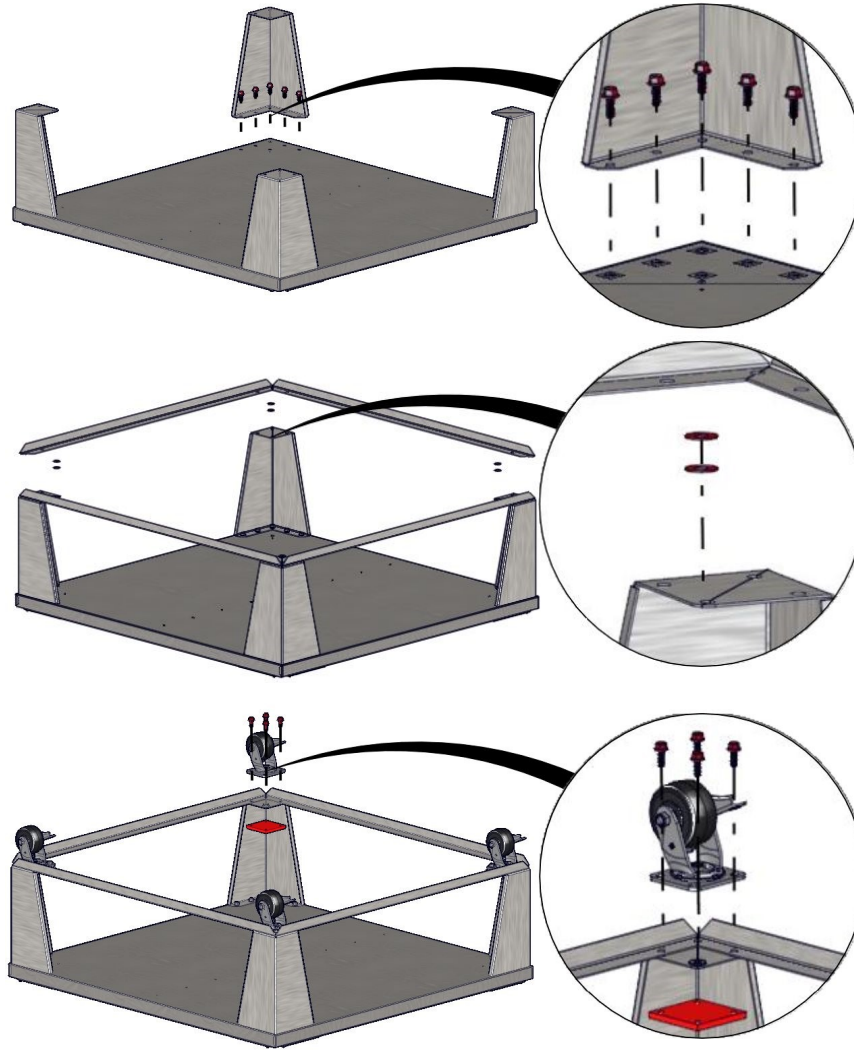

Base Assembly - Triple Stack

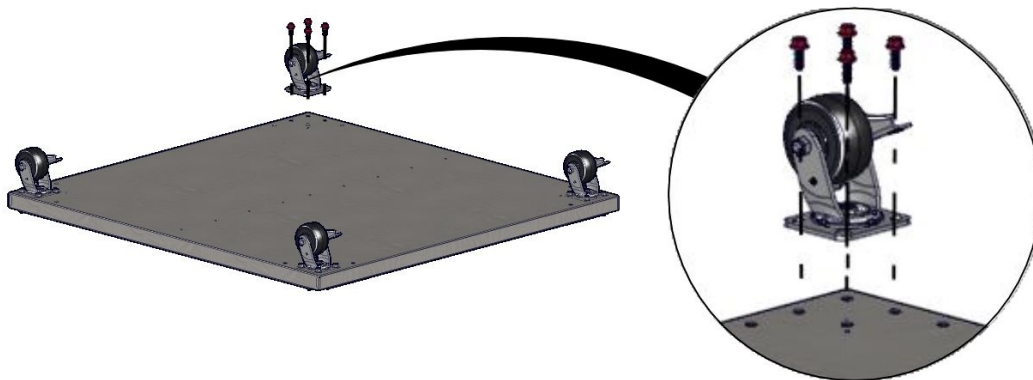



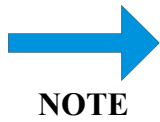
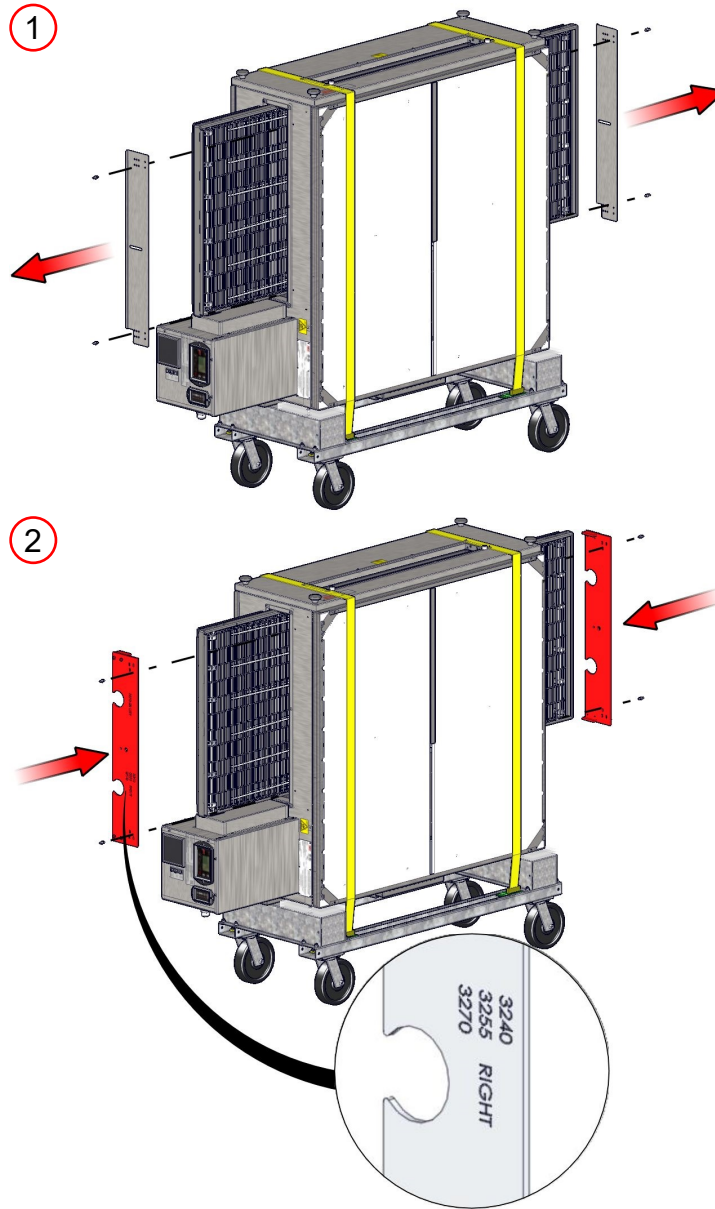

Review and understand the next eight (8) steps first. They illustrate how to stack the ovens safely.

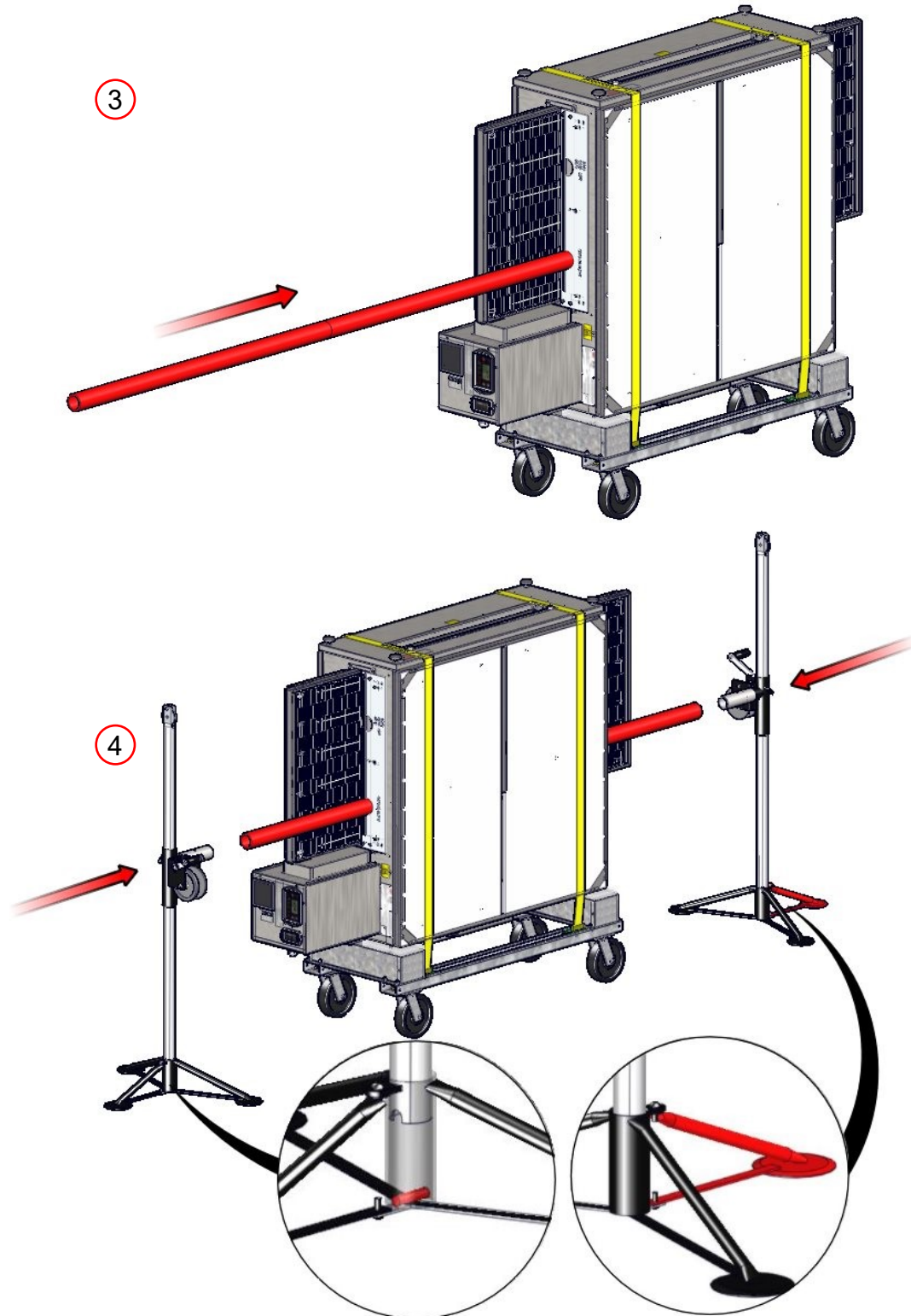

The Lifting Pipe hole, marked for the appropriate oven size, must be installed closest to the control box. If your lifting plates do not have all of our available sizes listed follow the table below.

Oven Size	Use Lifting Plate Position
3250	3270-2B
3265	3270-2B
3280	3270-2B
3880	3870-2B



 The folding leg of the tripod must be positioned outward from the oven.

NOTE

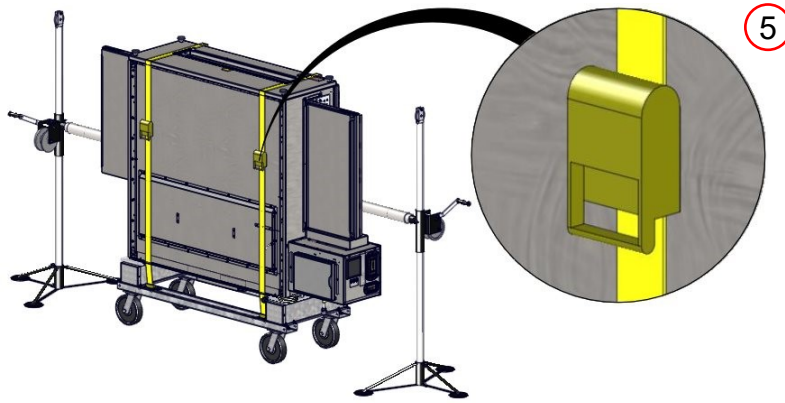

NOTE

Use the release tab on the strap to loosen and remove both straps.

Stacking the Ovens



DANGER

Failure to engage the Lifting Jacks into the Lifting Pipe properly and completely will result in damage, injury, or death from a falling oven.



DANGER

- Both jacks should be raised in unison, otherwise they may bind and a dangerous situation will develop.
- Do not put any part of yourself under the oven at any time.
- The oven is top heavy. Be careful.

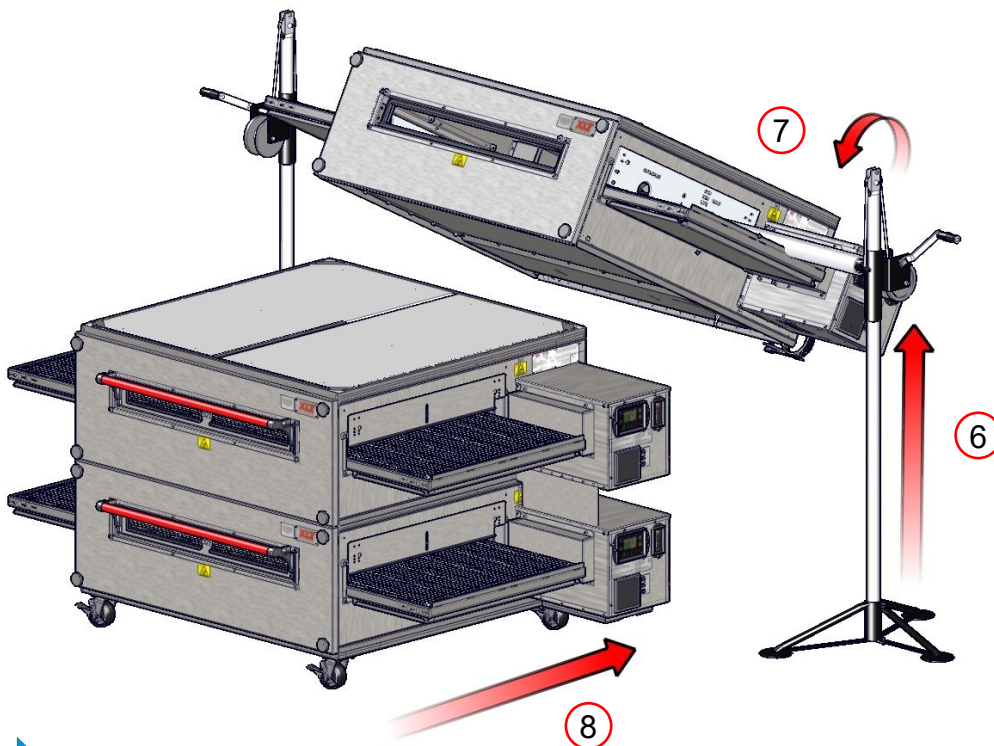

NOTE

DS model ovens may be used in single or double oven stack configurations only.



Individuals with pacemakers or internal medical devices should not handle strong rare-earth magnets. These magnets are found in the sandwich door assembly.

Removing Finger Clips

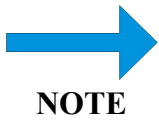
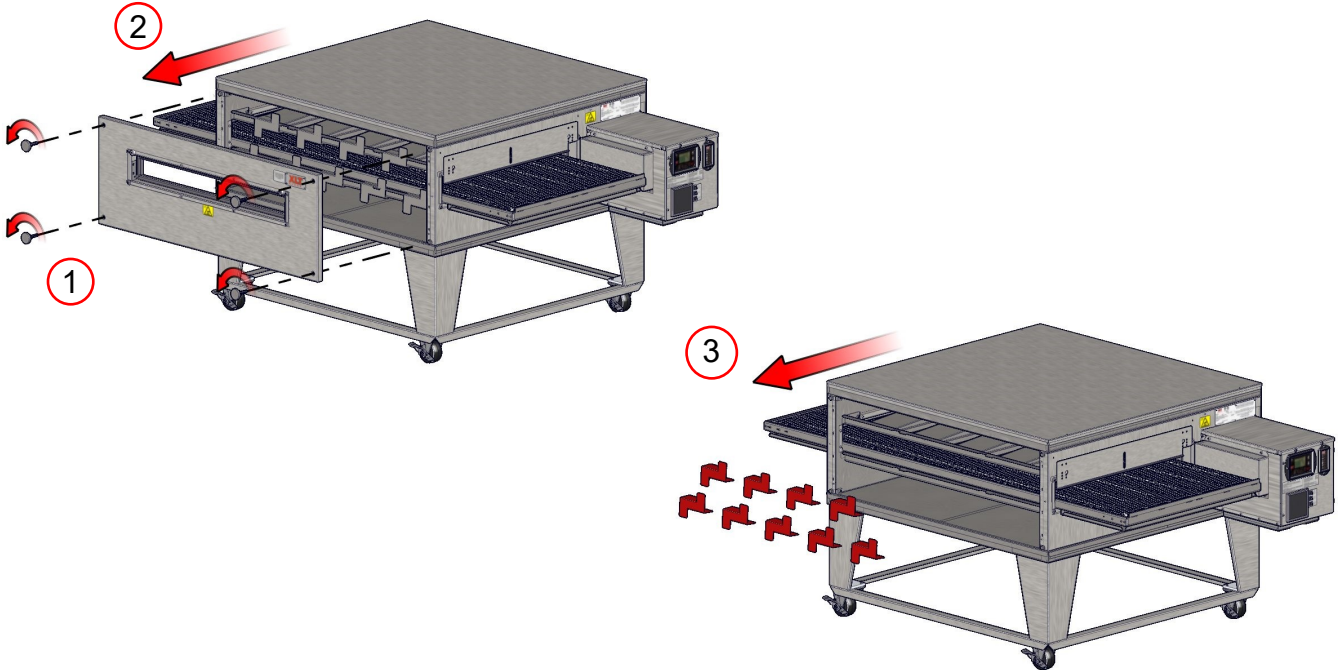

All DS model front panels will have lifting handles.

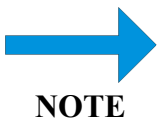

Finger clips for transportation purposes only. Discard once removed.

Installing Sandwich Door

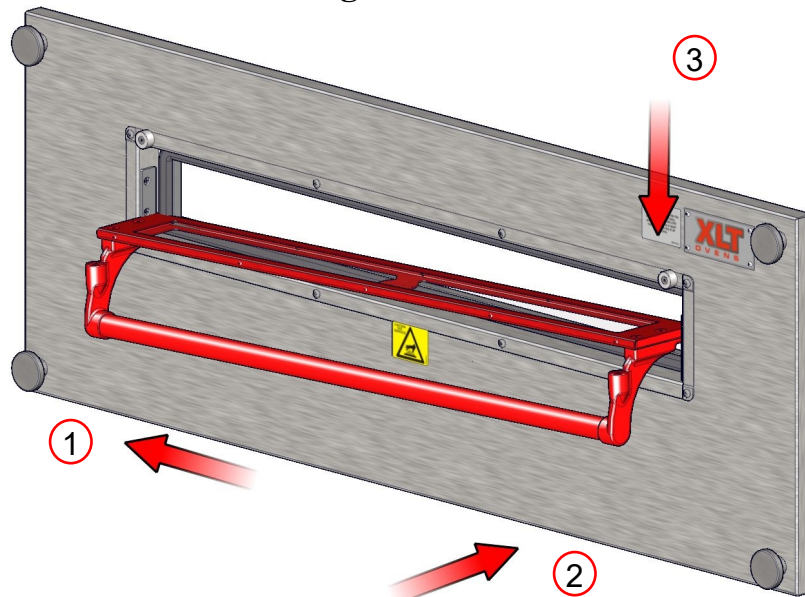

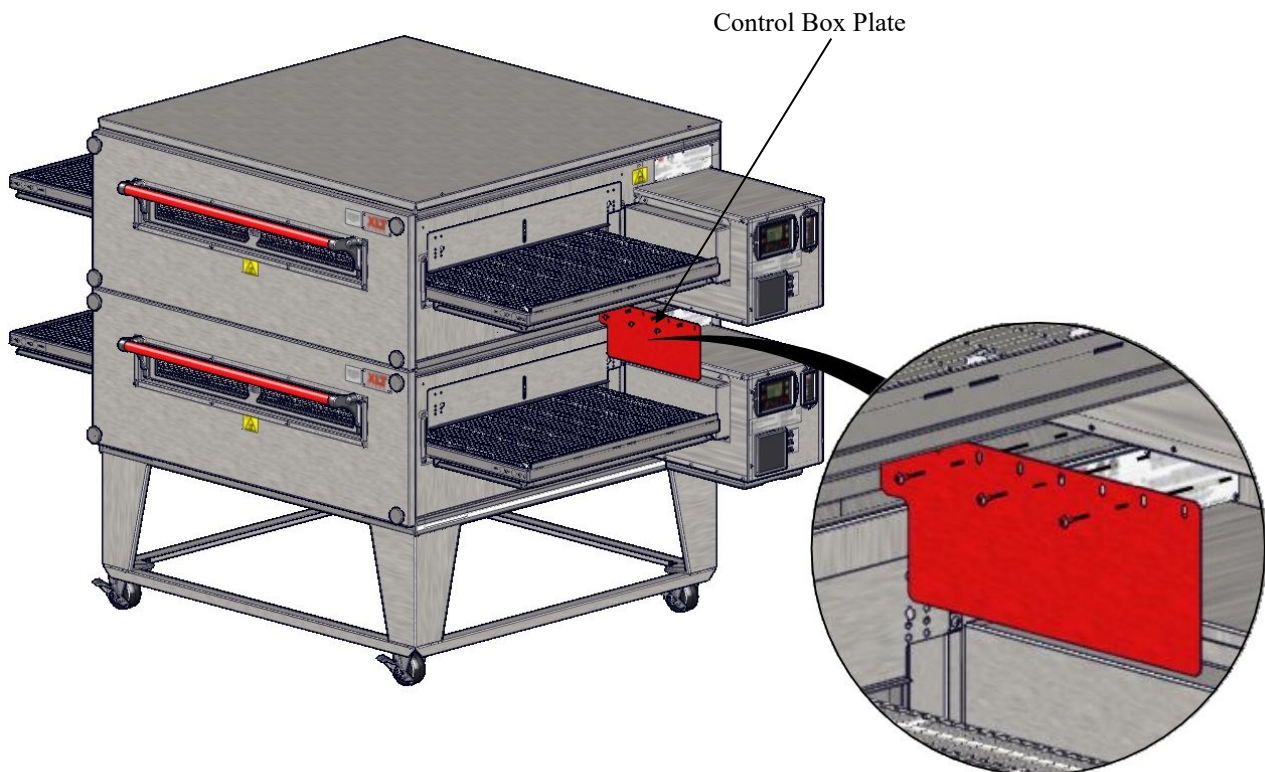
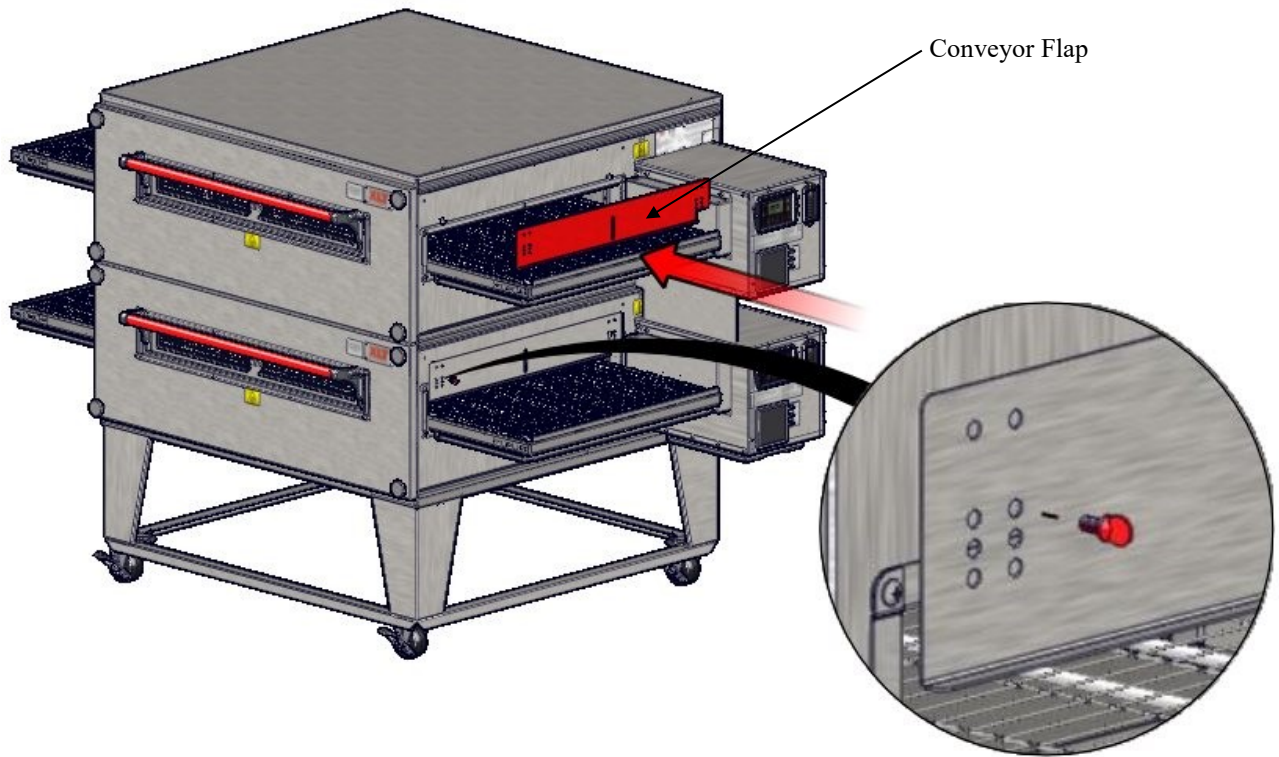

Physical Location & Spacing Requirements

These ovens are suitable for installation on either combustible or non-combustible floors, and adjacent to either combustible or non-combustible walls. The motor cover is designed to provide the proper clearance to the back of the oven. The minimum side clearances are 6in. / 150mm, measured from the end of the conveyor.



**All installations must conform to local building and mechanical codes.
In Australia, install the restraint cable in accordance with AS 5601.**

Restraint

Because all ovens are equipped with casters, all installations must be configured with a restraint to limit the movement of the oven without depending on the electric power supply cord or gas hose to limit the oven movement. One (1) restraint kit, which includes one (1) eye bolt, one (1) stainless steel clip & a cable, is required for each oven stack, regardless if used on a single, double, triple or quad configuration. The clip should be installed in the lowest hole of the back wall on the control end of the lowest oven in the stack. The lag eye bolt must be installed into a structural member of a wall or the floor. It is the owner's responsibility to ensure the restraint is installed correctly.

Upon completion of performing any service or cleaning functions that require removal of the restraint, insure that it is correctly re-attached to the oven.

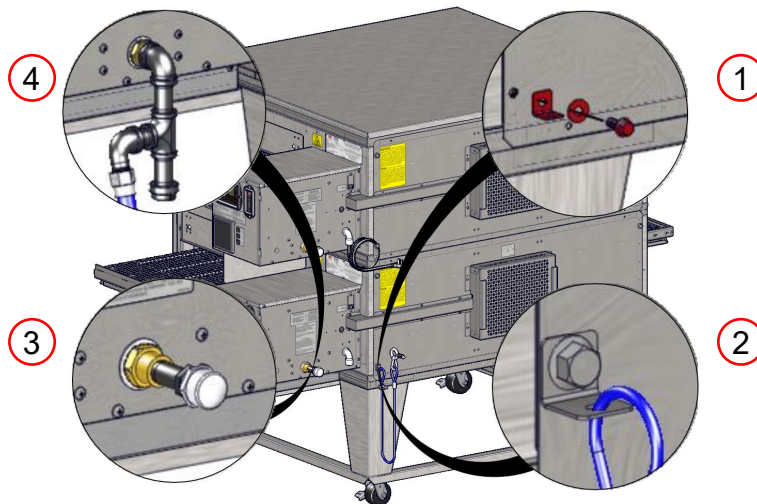

Sediment Trap

Connect sediment trap onto oven before connecting the gas hose. First remove the pipe with white cap from the rear of the control box (item 3 above) and install the supplied sediment trap in its place (item 4 above). Gas hose to hang vertically behind oven. The sediment trap is to be facing in the downward position as in step 4 above. A sediment trap is to be installed on all ovens.



Do not use Teflon tape on gas line connections as this can cause gas valve malfunction or plugging of orifices from shreds of tape. The use of Teflon tape could void your warranty. Contact XLT at 888-443-2751 with any questions.

The requirement for fire suppression systems vary by location and the authority having jurisdiction. If you are required to install fire suppression on your oven, a pre-assembled piping kit is available that utilizes pre-existing holes to simplify installation and future service.

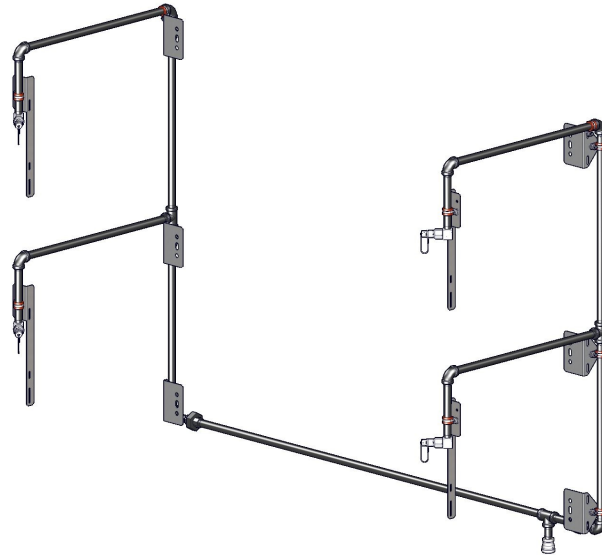

This design has been tested and approved to successfully comply with fire suppression codes. It uses only two (2) nozzles per bake chamber, and allows crumb trays, chain guards, and all other accessories to be easily removed. The kit does not interfere with any operations or maintenance.

For detailed information regarding fire suppression, see manual XD-9011 Fire Suppression Installation for XLT Hoods and XLT Ovens.

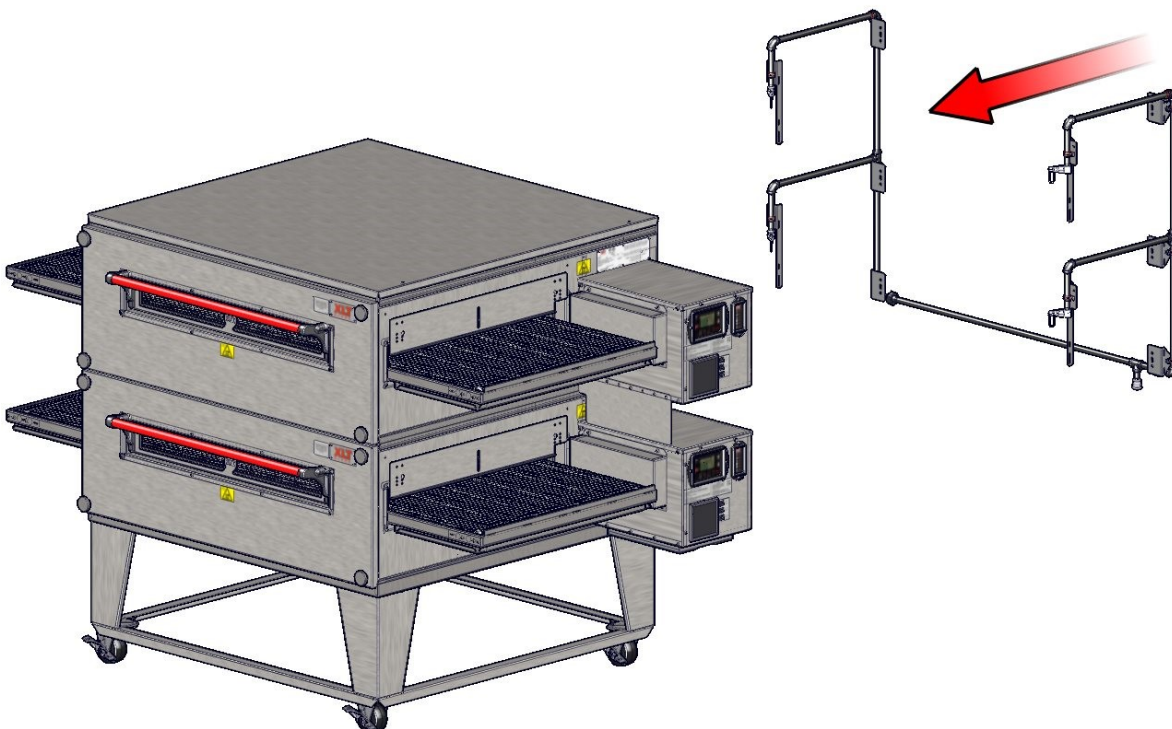

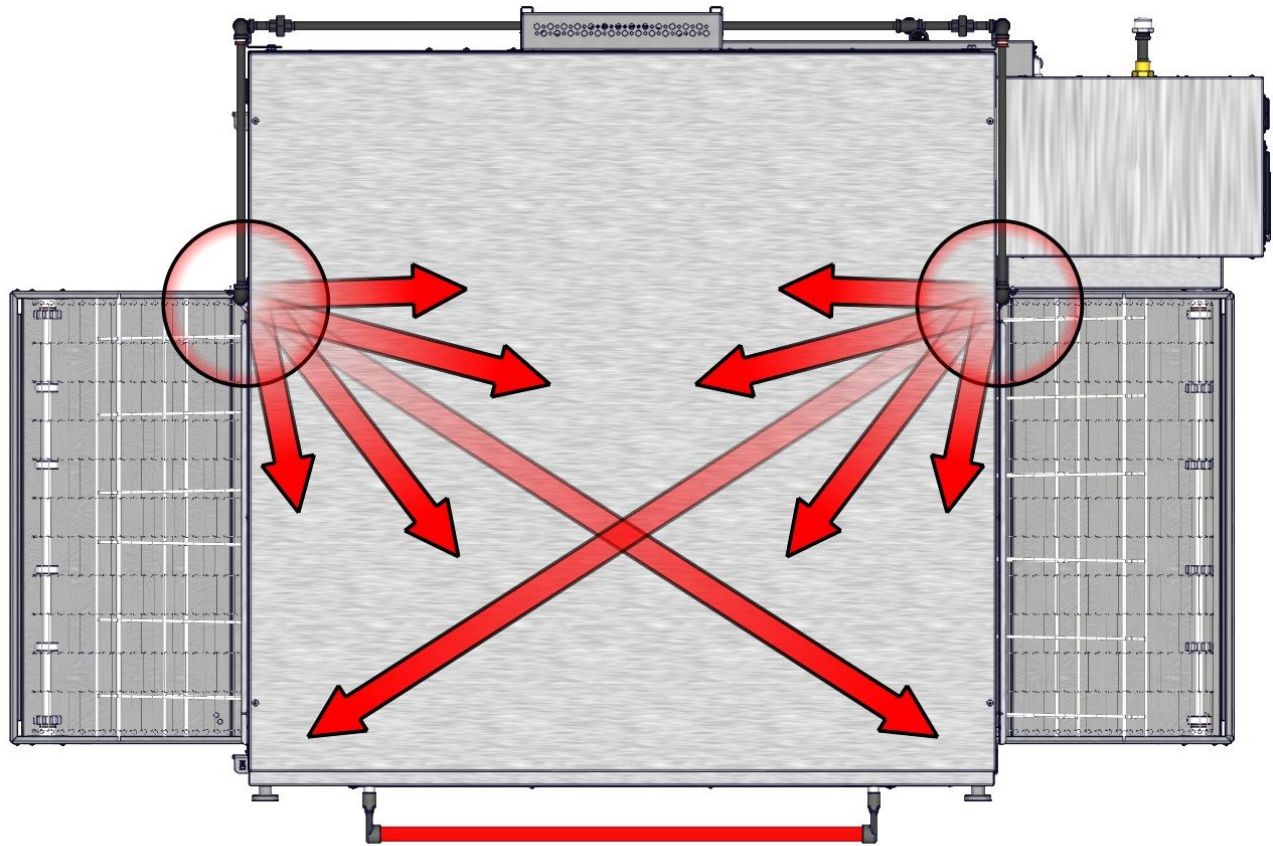
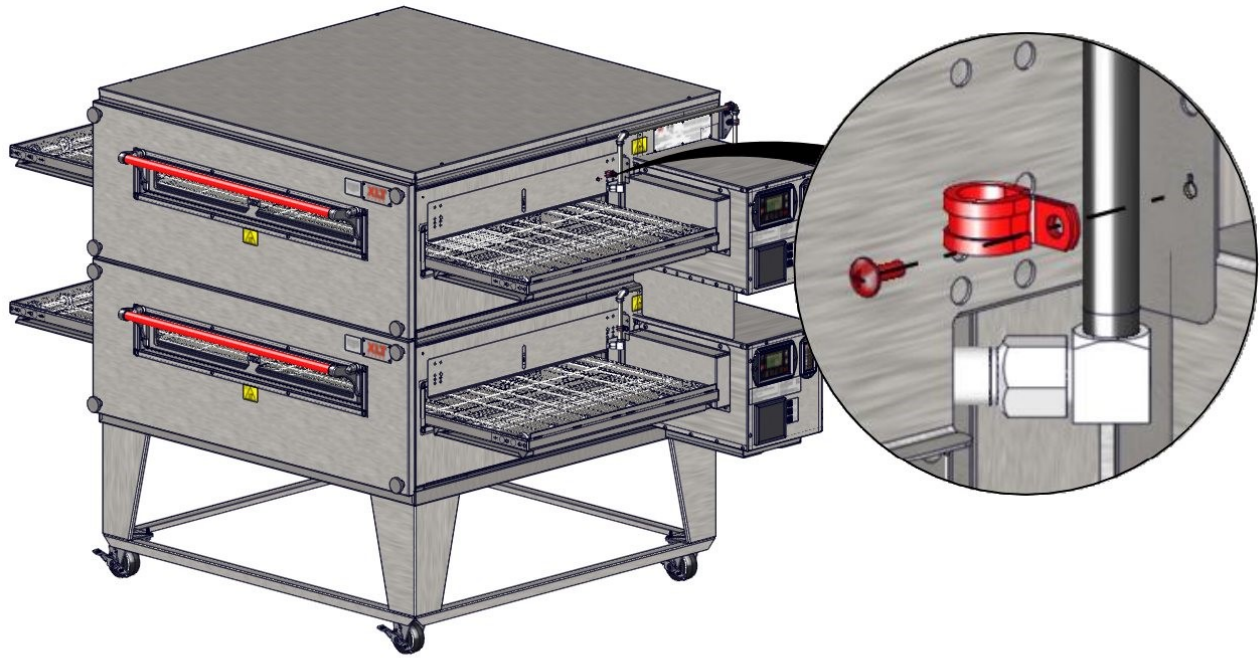

Ventilation Requirements

A powered ventilation hood is required to remove heat and vapors. Some provision must be made to replenish the amount of air that is extracted from the building. The hood and HVAC installation must meet local building and mechanical codes. Requirements vary throughout the country depending upon location. Proper ventilation is the oven owner's responsibility. The XLT hood system is designed to meet all requirements for XLT ovens and it is our recommendation that this system be used.

Ventilation Guidelines

Obtain information from the authority having jurisdiction to determine the requirements for your installation. Your ventilation hood supplier and HVAC contractor should be contacted to provide guidance. An air balance test is highly recommended, and should be performed by a licensed contractor. A properly engineered and installed ventilation hood and HVAC system will expedite approval, reduce all maintenance costs, and provide a more comfortable working environment. XLT also recommends that the operator controls for the ovens and the operator control for the exhaust fan be interlocked so that the exhaust fan gets energized whenever the ovens are turned on.

Ventilation Performance Test

After the oven and ventilation hood have been installed and are operating, a smoke candle can be used to "see" if the heat and vapors are being completely extracted. The test procedure is outlined below:

- The oven must be operating at user defined temperature
- The conveyor must be turned off
- The ventilation hood exhaust fan must be turned on
- Put a smoke candle in a pan on the conveyor belt at the center of the oven
- Observe the smoke pattern coming out of the oven
- Repeat the smoke candle test for each oven, as well as when all ovens are operating

The ventilation hood must capture all of the smoke from the oven.

After the exhaust fan has been adjusted to completely capture and contain the heat, there needs to be a corresponding amount of make up air (MUA) introduced into the building to offset the amount of air volume being removed. An air balance test can determine the proper amount of make-up air flow rates.

All ovens are tested at the factory for functional operation. Operation is verified and adjustments are made to ensure proper function. However, field conditions are sometimes different than factory conditions. **It is necessary to have an authorized service technician verify operation and make field adjustments if needed.**

The Oven Initial Start-Up Checklist, found at the end of this manual, must be completed at time of installation, signed by the Customer and returned to XLT and the Authorized Distributor to initiate Warranty Policy. **If the Start-Up Checklist is not filled out completely and returned to XLT the warranty will not be honored.**

Start-up Procedure

1. Ensure that all ovens have been installed in accordance with the Installation & Operation Manual and that all utilities are connected to the ovens in compliance with local building codes.
2. Place all control boxes in service position and verify incoming gas pressure (Refer to Parts & Service manual for gas valve adjustments). If gas pressure is not within XLT specifications contact gas company to adjust.
3. With all appliances running, check the dynamic gas pressure. If gas pressure is not within XLT specifications contact gas company to adjust.
4. Complete Start-up checklist with owner signature and return to XLT.



CAUTION

Do Not Exceed 65 Hz On VFD Settings.



NOTE

All XLT ovens will come programmed for a bake time of 5:00 minutes and a temperature of 500°F/260°C. End users are responsible for determining oven settings. The tables below indicate minimum and maximum values for bake time and temperature.

Conveyor Belt Times		
Oven Models	MINIMUM	MAXIMUM
1832	1:30	17:00
xx36-xx80	1:30	20:00

Oven Operating Temperature Range		
Oven Models	MINIMUM	MAXIMUM
All	300° F	590° F
	150° C	310° C

Integrated Control Package



This oven is not capable of being safely placed in operation in the event of a power failure. No attempt should be made to operate this oven during power failure.

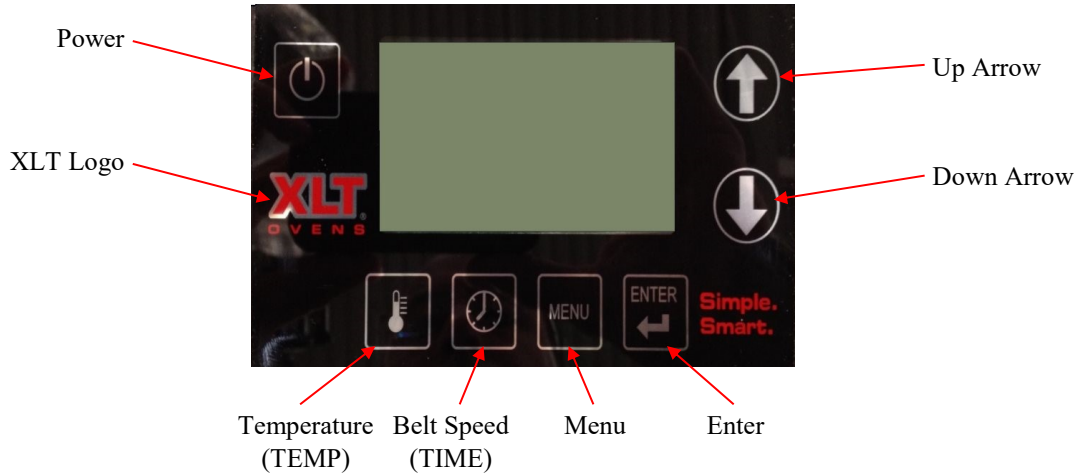

1 **TURN ON:** Hold the Power Button for one (1) second. Press the Enter button

Temperature Adjustment



2 **TEMPERATURE ADJUST:** Press TEMP button for three (3) seconds. To adjust temperature use either the Up or Down arrow. If double burner press the TEMP button to toggle between burner temps. Press Enter to save.

Belt Time Adjustment



3 **BELT TIME ADJUST:** Press TIME button for three (3) seconds. To adjust belt time use either the Up or Down arrow. If split belt, press the TIME button to toggle between belt times. Press Enter to save.

4 **TURN OFF:** Hold the Power Button for one (1) second.

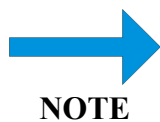

**Control box package may vary based on date of manufacture. Control package shown above for overall oven reference only.

Integrated Control Package

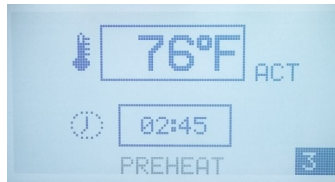
Menu Mode (Optional)

The Menu programming can store up to twelve (12) preset menus that can be recalled by number as needed. Each program contains a specified baking temperature and belt time.

To Select A Menu Program

1. Enter Menu mode by pressing MENU for one (1) second. The number in the lower right hand corner will begin flashing.
2. Use the Up and Down arrows to scroll through the numbered menu programs.
3. To select a desired menu program press Enter for one (1) second. A black box will appear around the number (refer to above image) and will be present on the operating screen.
4. Displays will auto-exit programming screens after five (5) seconds of no activity.

To Cancel A Menu Program

1. Enter Menu mode by pressing MENU for one (1) second. The number in the lower right hand corner will begin flashing.
2. Press MENU for one (1) second again. The operating screen will return without a programmed menu in use and without a number in the lower right hand corner of the screen.

To Change Menu Setting

1. To change a setting, when the number is flashing go to desired preset and press ENTER and MENU for three (3) seconds.

Additional User Options**Lock Settings**

1. To lock and unlock oven time and temperature press TIME and ENTER for three (3) seconds till the LUI beeps once.
2. Then press TEMP, TIME, then TEMP individually within three (3) seconds to lock settings.
3. A lock or unlock symbol will show up in the lower left corner of the LUI.

Fahrenheit To Celsius

1. To change temperature from Fahrenheit to Celsius press and hold TEMP and ENTER for three (3) seconds and the settings will change.

Integrated Control Package

Oven Machine Control LED's Status:

Oven Machine Control

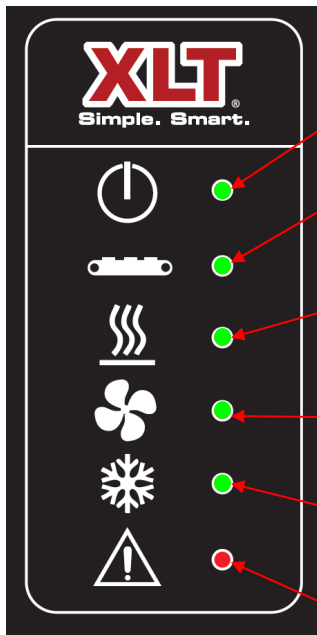

(All LED's on for reference)

Power Green



Steady: Oven has power.

Conveyor Green



Steady: Conveyors are active.

Flash: Problem is detected.

Heat Green



Steady: Oven is calling for heat. Will remain lit while climbing to temperature.

Flash: Problem is detected.

Main Fan Green



Steady: Fan is spinning.

Flash: Problem is detected.

Cool Down Green



Steady: Oven is in cool down mode.

Alarm Red



Steady: Alarm is tripped.

Flash: Some failure conditions will cause a flashing LED.

Integrated Control Package

Split Belt Conveyor Time Controls

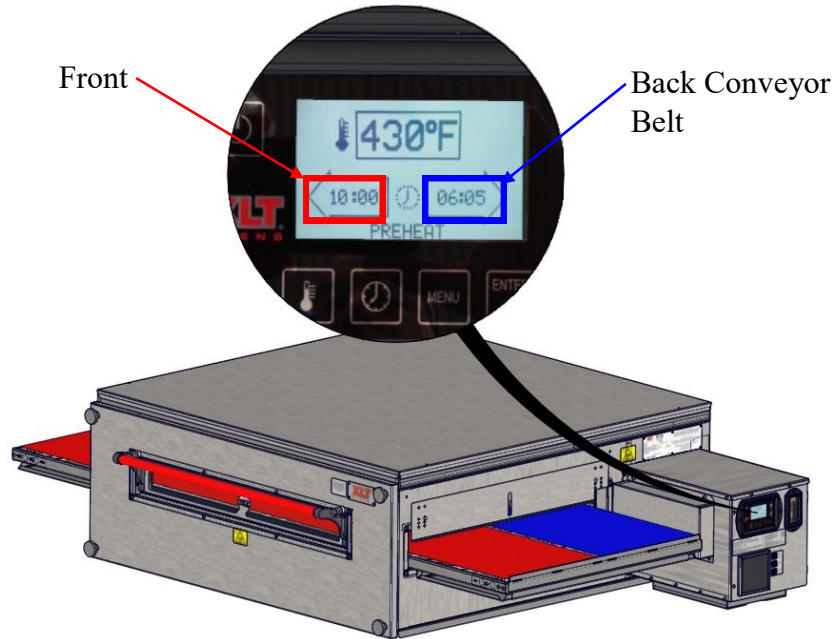

To maintain optimal bake new fingers may be needed if belt direction is changed



If Standard belt, only one (1) conveyor time will be displayed (refer to image below).

Standard Belt Conveyor Time Control

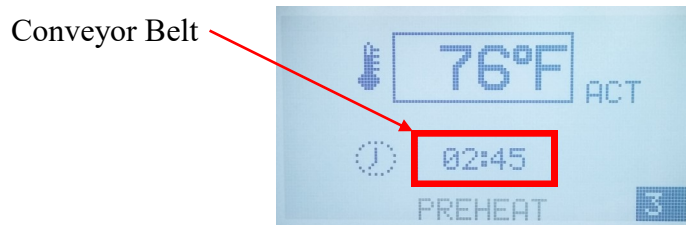

Integrated Control Package

Dual Burner Temperature Controls

3270-2B, 3870, 3280, 3265-DS, 3280-DS and 3880-DS Only

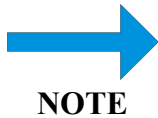
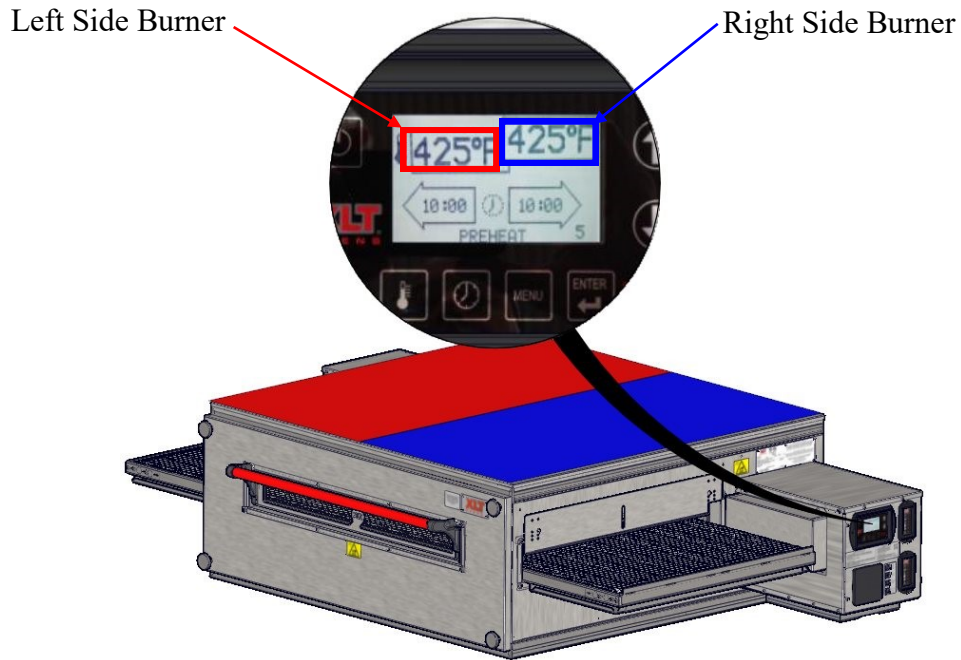

If Single burner, only one (1) temperature will be displayed (refer to image below).

Single Burner Temperature Control

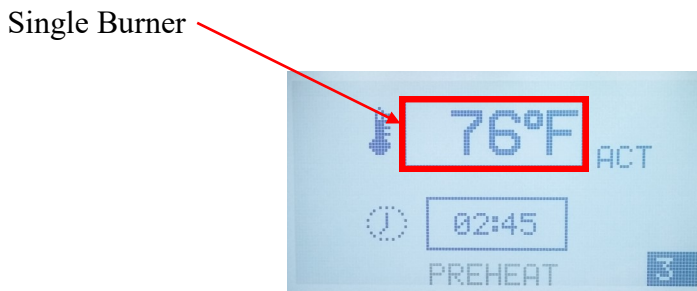

Discrete Control Package



Conveyor Belt
(Standard Belt)

Use Up Arrow to Increase Time
Use Down Arrow to Decrease Time

Conveyor Belt Times		
Oven Models	MINIMUM	MAXIMUM
All	1:30	17:00

Split Belt Conveyor Time Controls

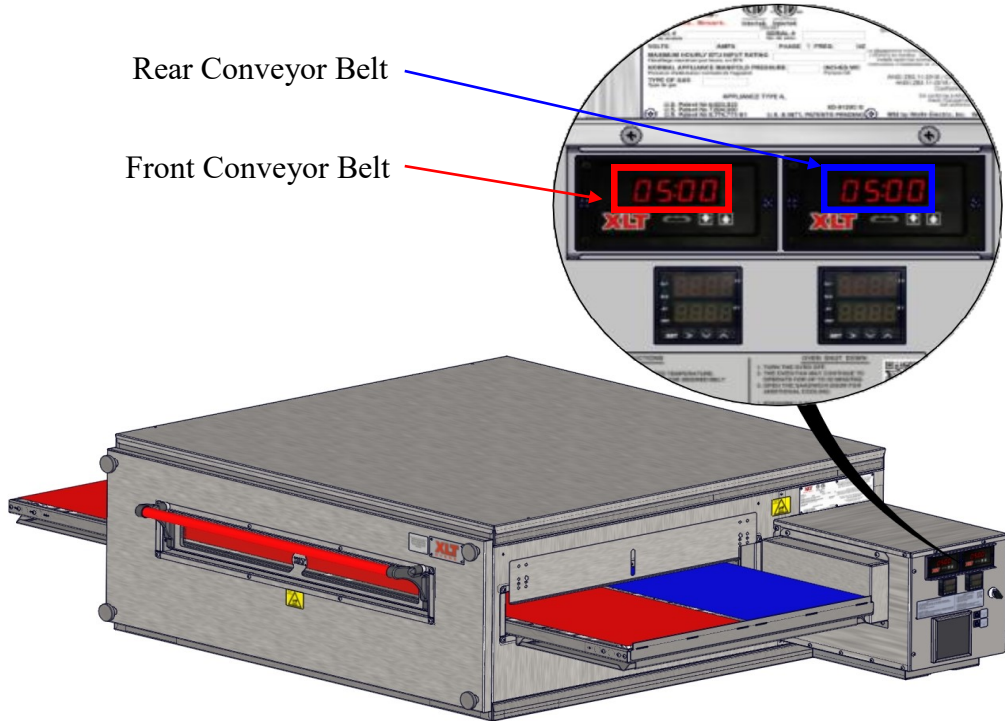

Rear Conveyor Belt

Front Conveyor Belt

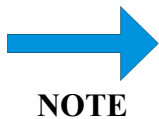

To maintain optimal bake new fingers may be needed if belt direction is changed

Discrete Control Package

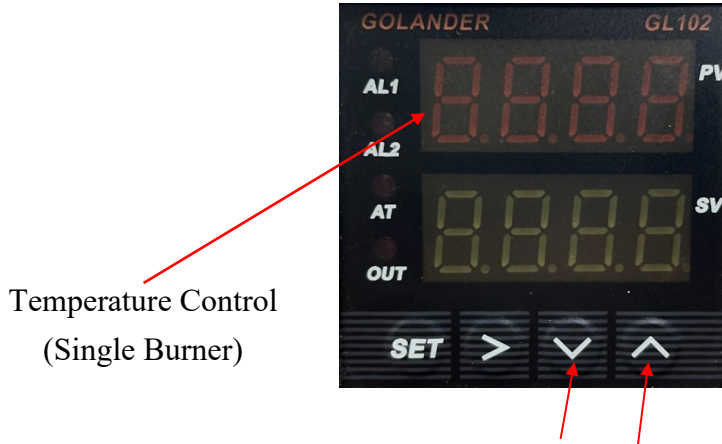

Temperature Control
(Single Burner)

To Adjust Temperature, Press Either the
Up or Down Arrow



Manufacturer recommends that the temperature limit does NOT exceed 600°F when operating ovens utilizing the discrete control package.

Dual Burner Temperature Controls

3270-2B, 3870, 3280, 3265-DS, 3280-DS and 3880-DS Only

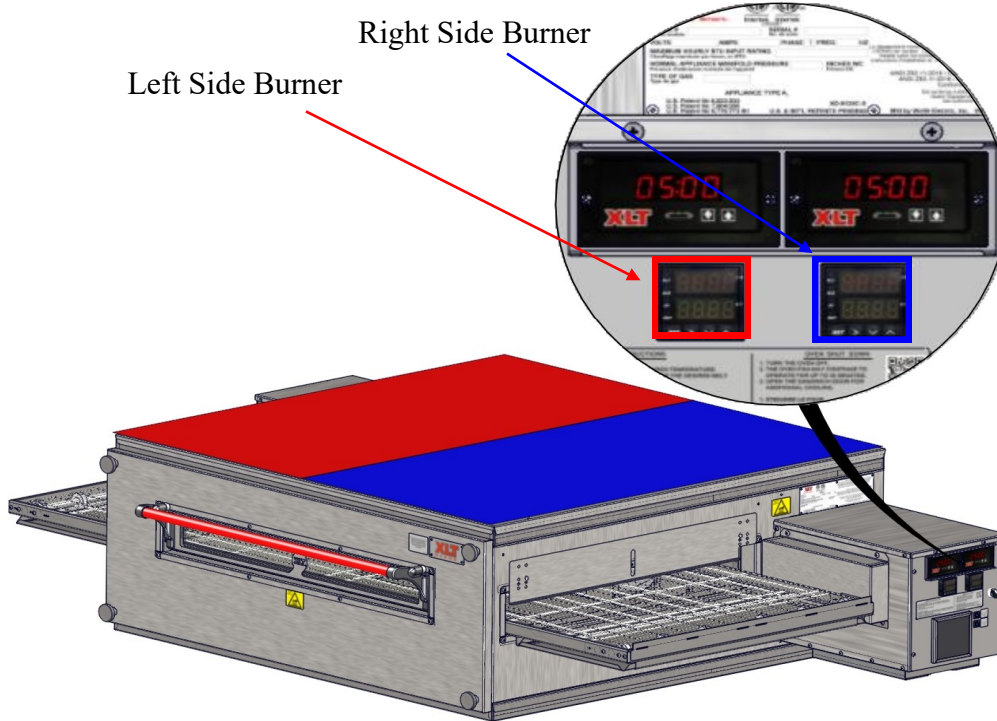

Your XLT oven is constructed of stainless steel. Most commercial cleaning agents may be used safely on all stainless steel surfaces. Check application restrictions on product label prior to usage. Observe recommended precautionary and safety measures as dictated by the product manufacturer. Bleach can cause stainless steel to discolor and corrode and is not recommended for cleaning.

Do not use caustic cleaners on the conveyor bearings as they will cause irreversible damage to the part.

Do not use abrasive cleaners or abrasive pads as they can scratch stainless steel surfaces. Areas with heavy buildup should be sprayed and allowed to soak for up to five (5) minutes prior to wiping clean. Always wipe with the “grain” of the surface to maintain appearance.

Do not use caustic cleaners on the control panel and/or electronic components. Only use cleaners compatible with Lexan® on the face of the conveyor control.

The most critical item to be cleaned is the filter on the fan. The filter is held in place by the stainless steel fan guard/filter mount and can be washed several times. Regular cleaning of the filter is important to maintain air circulation within the control box. This filter should be cleaned daily to maintain optimal air flow to the control box. Please contact XLT for replacement parts.

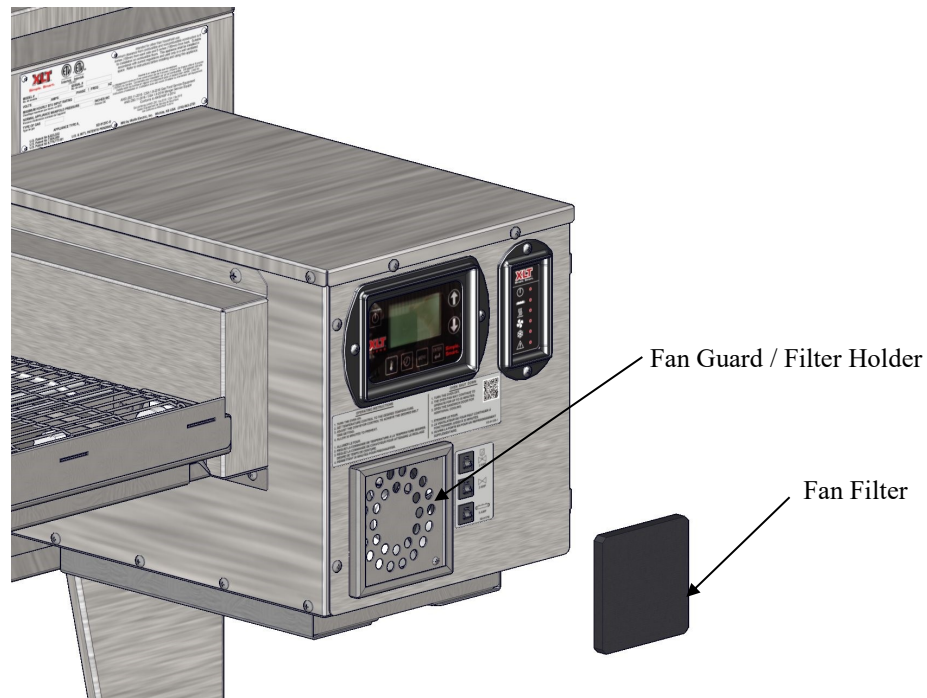

Fan Filter Maintenance

1. When fan filters need to be cleaned, an alarm will appear on the LUI saying “FILTER”.
2. Clean the fan filter.
3. Press the MENU button to enter the “FILTER RESET” screen.
4. Press ENTER to reset the filter timer. This will take you to another screen which will show you the timer back at 00:00 and will exit after five (5) seconds.

**DANGER**

Oven must be cool and the electric cord unplugged before any cleaning or maintenance is done.

**CAUTION**

If the oven is to be removed from its installed location for cleaning or servicing, the following procedure is to be followed:

1. Shut off main manual gas valve
2. Unplug electric cord
3. Unplug gas line
4. Unlock casters
5. Disconnect restraint
6. Disconnect hood relocation cords (if applicable)
7. When servicing or cleaning is complete, move oven to original location
8. Connect hood relocation cords (if applicable)
9. Connect restraint
10. Lock casters
11. Plug in electric cord
12. Plug in gas line
13. Turn manual gas valve on
14. Follow normal lighting instructions

**TIP**

Read and understand the next thirteen (13) steps first. They illustrate how to remove components from the oven for cleaning.

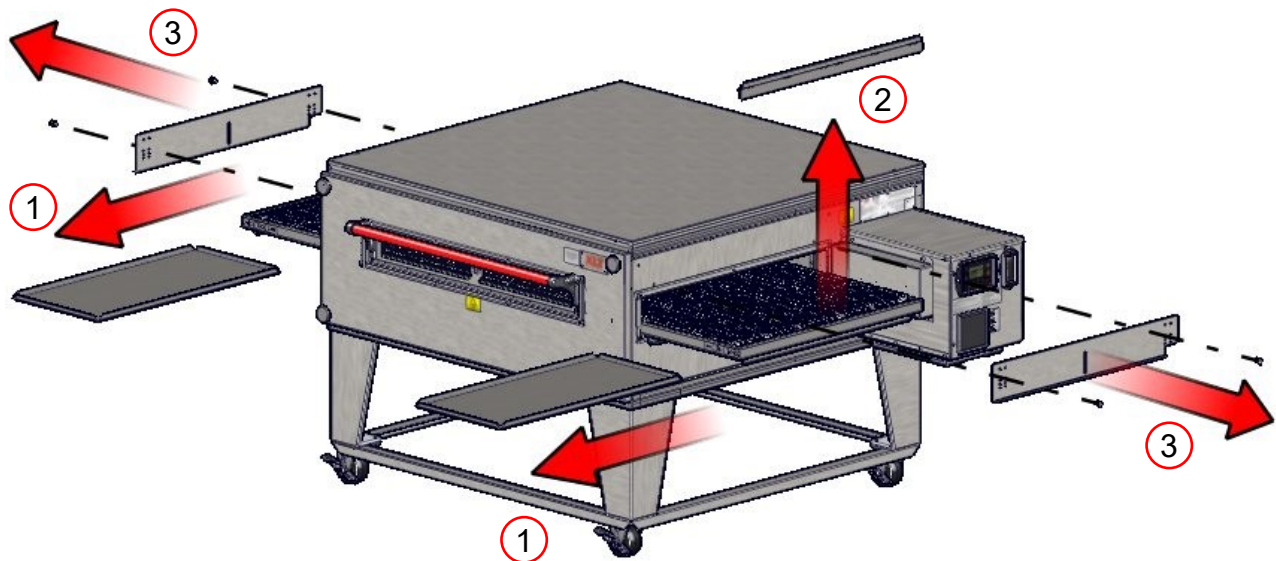



Opening the Sandwich Door will provide a grip location for removing the Front Panel.

TIP**CAUTION**

Front Panels can weigh up to 94 lbs. [42 kg]. Use caution when lifting.

**WARNING**

Individuals with pacemakers or internal medical devices should not handle strong rare-earth magnets. These magnets are found in the sandwich door assembly.

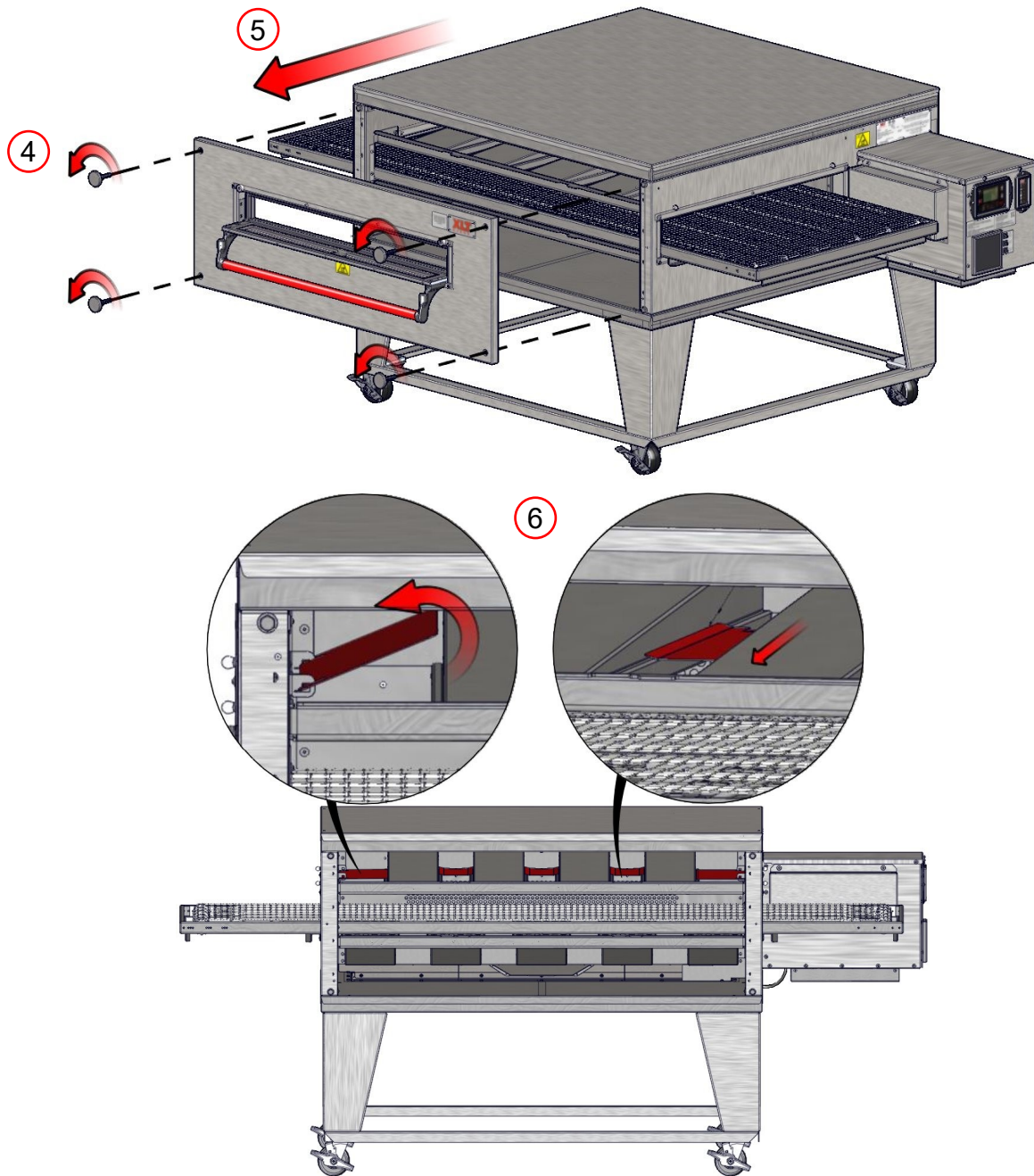

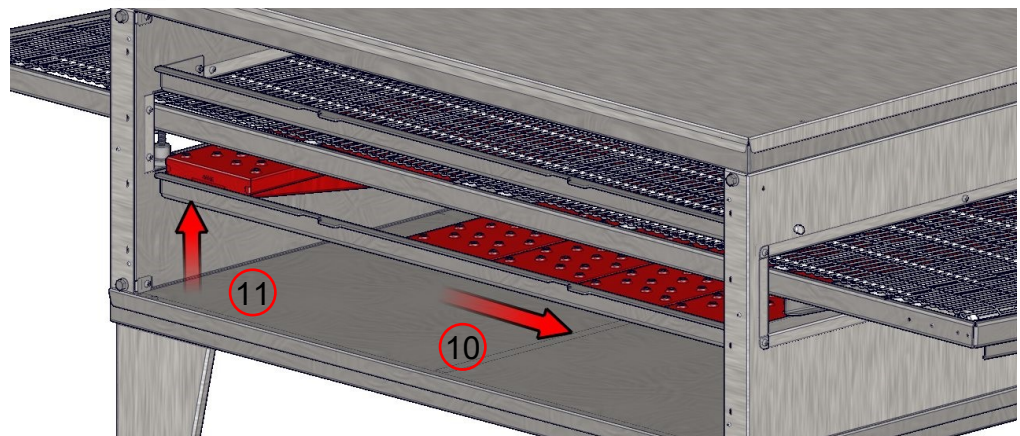
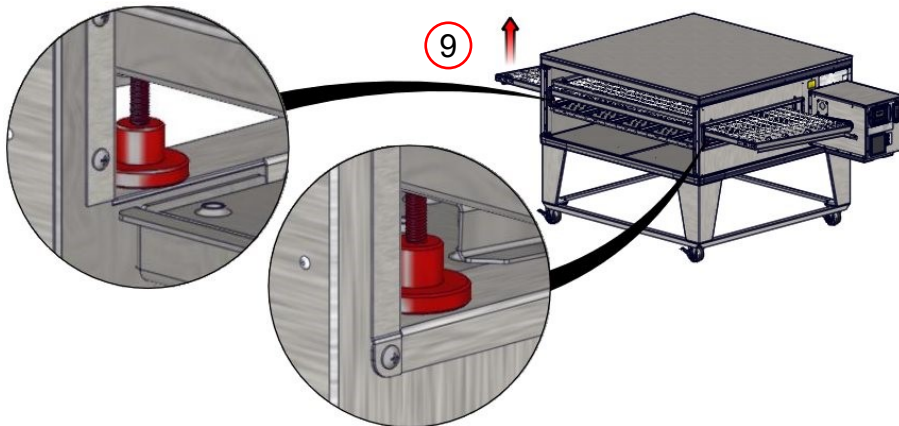
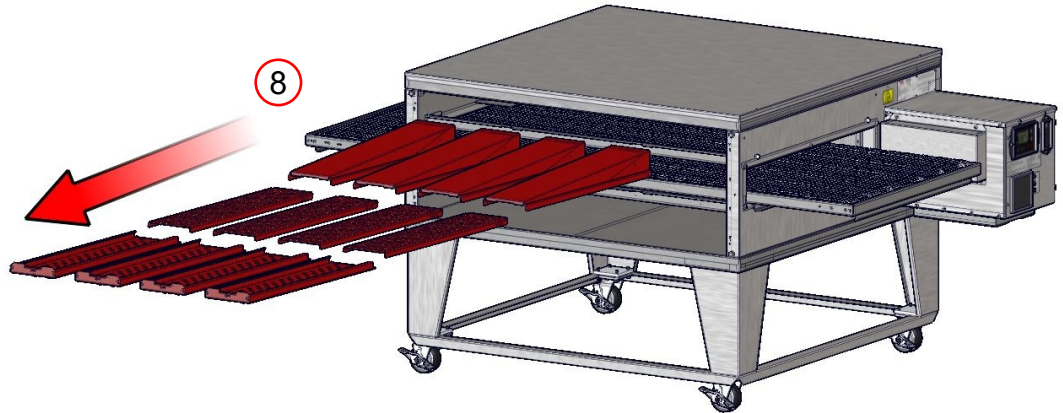
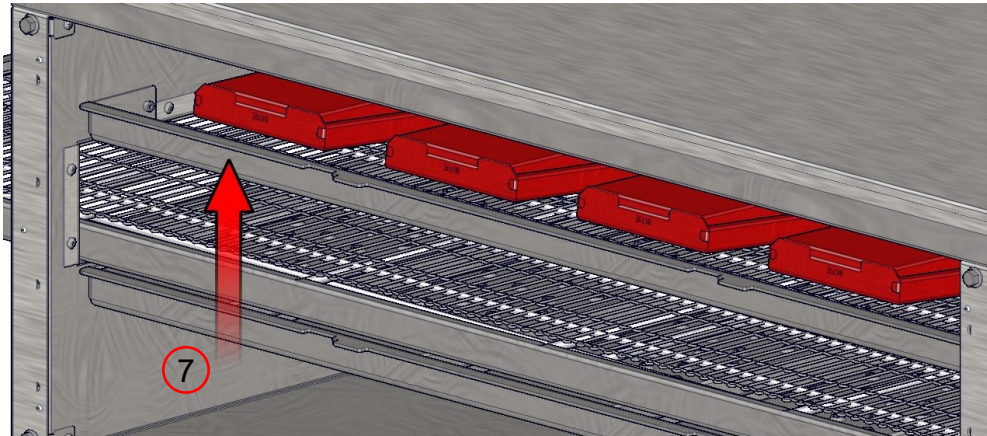

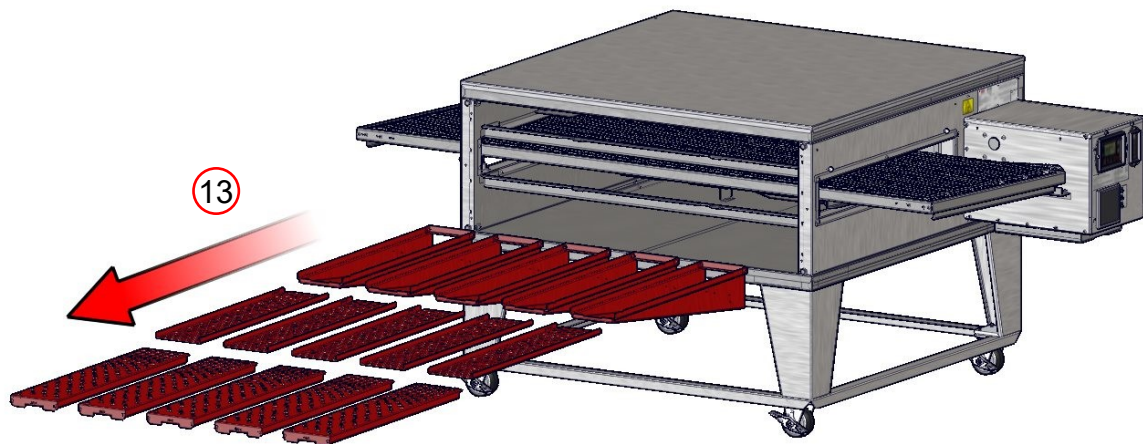
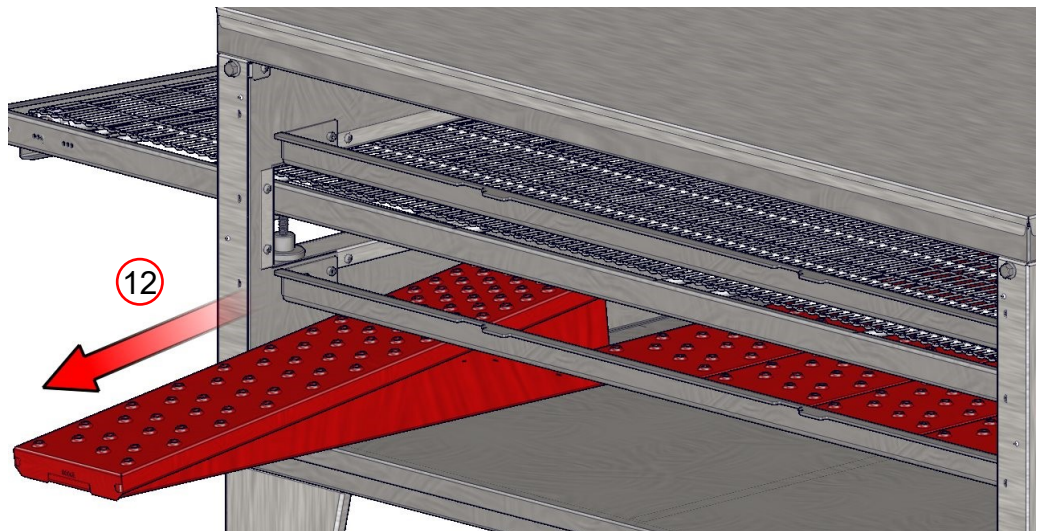
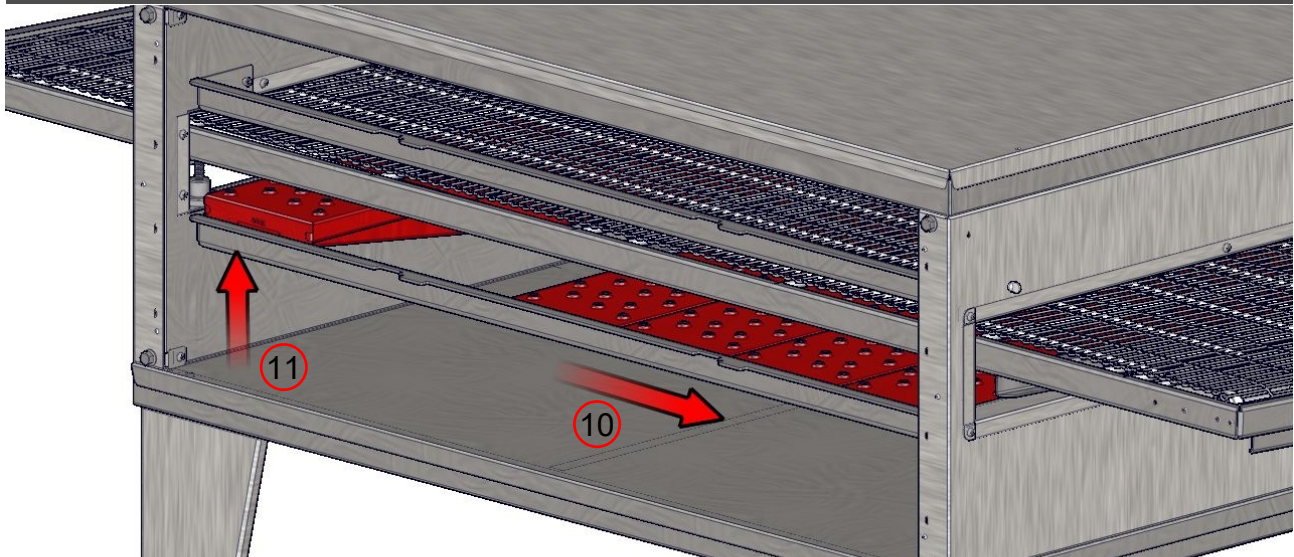

DO NOT spray liquid cleaning agents in the slots and holes in the rear of control box, underneath the control box, or the main fan motor cover.

As with any appliance, periodic maintenance is required. Many factors affect this schedule such as product mix and hours of usage. An example schedule is included.



Oven must be cool and the electric cord unplugged before any cleaning or maintenance is performed.

DANGER

Oven Maintenance Schedule					
		Daily	Weekly	Monthly	Semi-Annual
Cleaning					
	Empty Crumb Trays	<input type="checkbox"/>			
	Wipe down Front, Sides, & Top	<input type="checkbox"/>			
	Wipe down Control Box & Control Panel *	<input type="checkbox"/>			
	Clean Fan Filters	<input type="checkbox"/>			
	Remove large debris from Conveyor		<input type="checkbox"/>		
	Wipe down Motor Cover		<input type="checkbox"/>		
	Clean Sandwich Window		<input type="checkbox"/>		
	Remove debris from Finger Outers			<input type="checkbox"/>	
	Remove debris from inside Bake Chamber			<input type="checkbox"/>	
	Remove debris from Main Fan Motor			<input type="checkbox"/>	
	Clean Finger Outers				<input type="checkbox"/>
	Clean inside Bake Chamber				<input type="checkbox"/>
	Clean Conveyor Assembly				<input type="checkbox"/>
Inspection					
	Check Conveyor Wire Belt for Stretch		<input type="checkbox"/>		
	Check Conveyor Drive Roller Chain for Stretch			<input type="checkbox"/>	
Lubricate					
	Lubrication of Window Pins W/ Food Grade Grease			<input type="checkbox"/>	
	Conveyor Drive Roller Chain				<input type="checkbox"/>
Replace					
	Fan Filters				<input type="checkbox"/>

* Do not use caustic cleaners on the control panel. Only use cleaners compatible with Lexan® on the face of the conveyor control (refer to Pg. 48)

** To determine if the wire belt is stretched, pull up on the center of the belt at the conveyor opening. If the belt touches the top of the conveyor opening, links will need to be removed to adjust the tension. Refer to Wire Belt Adjustment section of Parts & Service Manual to remove links.

- Do not use caustic cleaners on the conveyor bearings (refer to Pg. 48)
- Do not use abrasive cleaners or abrasive pads (refer to Pg. 48)
- Do not use water jet (high pressure water stream) to clean the oven.

Proper Cooking

Experimentation is about the only way to determine proper time and temperature settings. While a food product may look perfectly cooked on the outside, the inside may be undercooked. A thermometer is necessary to determine if food items are being properly cooked. Most health departments have rules and regulations that establish minimum temperatures for internal food temperatures. Most operators want to cook foods as fast as possible in order to serve more customers per hour. However, cooking foods slower is the only way to achieve a proper internal temperature. If your food products look acceptable on the outside, but have an internal temperature that is too low, then lowering the temperature and decreasing the belt speed (thereby increasing the cook time), will be necessary.

Several factors may affect the cooking performance and characteristics:

- Oven temperature (generally affects color)
- Conveyor speed (generally affects doneness)
- Finger arrangement
- Altitude
- Pans versus screens
- Dough thickness
- Cheese type
- Raw ingredient temperature (frozen?)
- Quantity of toppings

XLT ovens can be configured to cook a wide variety of food items. This is accomplished by designing a finger group to control the baking characteristics. Generally speaking, most cooking is a “bottom up” process. The hot air from the bottom row of fingers has to go through the conveyor (a distance of about 2” / 50.8mm), heat the pan or screen, and then actually cook the food. The hot air from the top, on the other hand, basically only has to melt and re-heat precooked toppings. Consequently, most operators will use the oven with the fingers arranged so that a lot more air is directed to the bottom of the food than to the top. Finger cover plates are available that have six rows of holes, four rows of holes, two rows of holes, and no holes (or blank cover plates). A typical finger arrangement might have most or even all fingers on the bottom “full open”, that is fingers with all six rows of holes, and only two or three fingers on top with four or six rows of holes. The top fingers can be arranged in a symmetrical pattern or can be shifted asymmetrically to either the entrance or exit end of the conveyor. We encourage you to experiment by trying different finger arrangements, temperatures and belt speeds. XLT can assist you with your oven/product configurations.

Mechanical Function

If your oven does not function properly, please verify the following conditions:

1. Verify that the power cord to the oven is connected and/or plugged in if equipped with a plug and receptacle.
2. Check all circuit breakers on the oven control panel and on the back of the control box to ensure they have not been tripped.
3. Check to see that the circuit breakers in the building electrical service panel have not been tripped or turned off.
4. Check the manual gas valve to verify that it is turned on completely. The handle on the valve should be parallel with the gas piping when the valve is turned on, and the handle will be perpendicular with the gas piping when the valve is turned off. Also remember that anytime the gas hose has been disconnected it will take time to purge the air from the gas train.
5. Verify that oven is supplied with gas by disengaging and reengaging the quick-disconnect fitting on the gas hose.
6. Gas line size and pressure must be adequate to support total BTU requirements with all appliances in store turned on. Refer to the "Oven Gas Requirements" section of this manual.



HIGH

Proceed with caution and read the following instructions carefully when unplugging the units.

Hard Reset

If your oven still does not function properly, perform a hard reset. First, power down the unit then unplug the unit from all electrical power. Leave the unit unplugged for one (1) minute. Once this is done, plug the unit back in and turn on the power.

LUI Service Error Codes

Display Alarm	MC LED	Error Determination	Troubleshooting
Oven Probe	Alarm LED on. Flash HEAT LED. All other LED's operate as normal.	Temp Sensor Error, Open or Short. Temp <40F (4C) or >700F (371C)	Perform A Hard Reset. If Error Still Exists, Contact XLT.
Ignition Error	Alarm LED on. Flash HEAT LED. All other LED's operate as normal.	From Ignition enable (run) signal, if oven doesn't see 25F (-4C) temp rise in three (3) minutes. If restart (actual temp within 50F (10C) of set point) error timing ten (10) minutes.	Check To See If Gas Hose Is Connected. Next, Is Exterior Gas Valve On? If Yes, Perform A Hard Reset. If No, Turn Gas Valve On. If Error Still Exists, Contact XLT.
Over Temp	Alarm LED on. Flash HEAT LED. All other LED's operate as normal.	Temp is 50F (10C) over set point for period > one (1) minute. If user adjusts set point lower, inhibit alarm until new set point is reached.	Perform A Hard Reset. If Error Still Exists, Contact XLT.
Under Temp	Alarm LED on. Flash HEAT LED. All other LED's operate as normal.	Once set point is reached, the Actual is 15F (-9C) under set point for more than thirty (30) minutes. If user adjusts set point, reset timer.	Check To See If Gas Hose Is Connected. Next, Is Exterior Gas Valve On? If Yes, Perform A Hard Reset. If Error Still Exists, Contact XLT.
Over Speed	Alarm LED on. Flash CONVEYOR LED. All other LED's operate as normal.	Speed > thirty (30) seconds fast Duration vs. Set Point	Perform A Hard Reset. If Error Still Exists, Check LUI Settings. If Settings Are Correct, Perform A Pan Test To Confirm Settings. If Error Still Exists, Contact XLT.
Under Speed	Alarm LED on. Flash CONVEYOR LED. All other LED's operate as normal.	Speed > thirty (30) seconds slow Duration vs. Set Point	Check Drive Chain and Sprocket To Verify Proper Working Condition. Perform A Hard Reset. If Error Still Exists, Check LUI Settings. If Settings Are Correct, Perform A Pan Test To Confirm Settings. If Error Still Exists, Contact XLT.
Software Error	Alarm LED flash. All other LEDs off.	Internal Software Error	Check for pinched wires. Perform A Hard Reset. If Error Still Exists, Contact XLT.
EEPROM Error	Alarm LED flash. All other LEDs off.	Bad Checksum	Perform A Hard Reset. If Error Still Exists, Contact XLT.
Key Short	Alarm LED flash. All other LEDs off.	Any Key Shorted > one (1) minute.	Clean LUI Screen. Verify LUI software is version 50 (v50) or later in Tech Mode. Perform A Hard Reset. If Error Still Exists, Contact XLT.
Comm Error	Alarm LED flash. All other LEDs off.	Internal Software Error	Perform A Hard Reset. If Error Still Exists, Contact XLT.
Main Fan Low Amps	Alarm LED on. Flash FAN LED. All other LED's operate as normal.	Amps below min level per Main Fan Amp level table for ten (10) seconds.	Perform A Hard Reset. If Error Still Exists, Contact XLT.
Main Fan High Amps	Alarm LED on. Flash FAN LED. All other LED's operate as normal.	Amps above max level per Main Fan Amp level table for ten (10) seconds.	Check CB1 To See If It Has Tripped. If Yes, Reset CB1. If No, Perform A Hard Reset. If Error Still Exists, Contact XLT.

If your oven still does not function properly, XLT has qualified customer service personnel that can provide assistance on any type of XLT equipment problem you may experience. Customer Service is available 24/7/365 at 888-443-2751, or visit www.xltovens.com.

This page is intentionally left blank.

**DANGER**

Check all local codes prior to installation. Special requirements may be necessary depending upon building material construction. It is the installing contractor's responsibility to ensure that the structure the hood is to be hung from meets all codes and can carry the hood weight.

Purchaser's Responsibility

It is the responsibility of the purchaser:

1. Thoroughly review the floor plans and specifications. The exact location of the oven must be determined before installing the hood.
2. To unload, uncrate, assemble, and install the hood to its intended location.
3. To ensure that electric utilities are installed on site in accordance with local building codes and meet the specifications in this manual.
4. To see that electric utilities are connected properly by a qualified installer using the proper hardware.
5. To ensure a qualified installer has performed an initial start-up procedure.
6. Location should minimize long and twisted duct runs, and make efforts to have a straight clear path to the roof/wall fan curb.
7. All hood supporting structures must be strong enough to support the weight of the hood and shrouds. Refer to the Hood Dimensions & Weights page for weight.
8. Maintain the proper clearances from combustible materials according to International Mechanical code (IMC), and National Fire Protection Agency (NFPA) 96, and local mechanical codes.
9. In Australia, a ventilation hood to be installed in accordance with AS 5601 Gas Installation.
10. To Ensure that the XLT Hood is suspended properly from the ceiling structure.

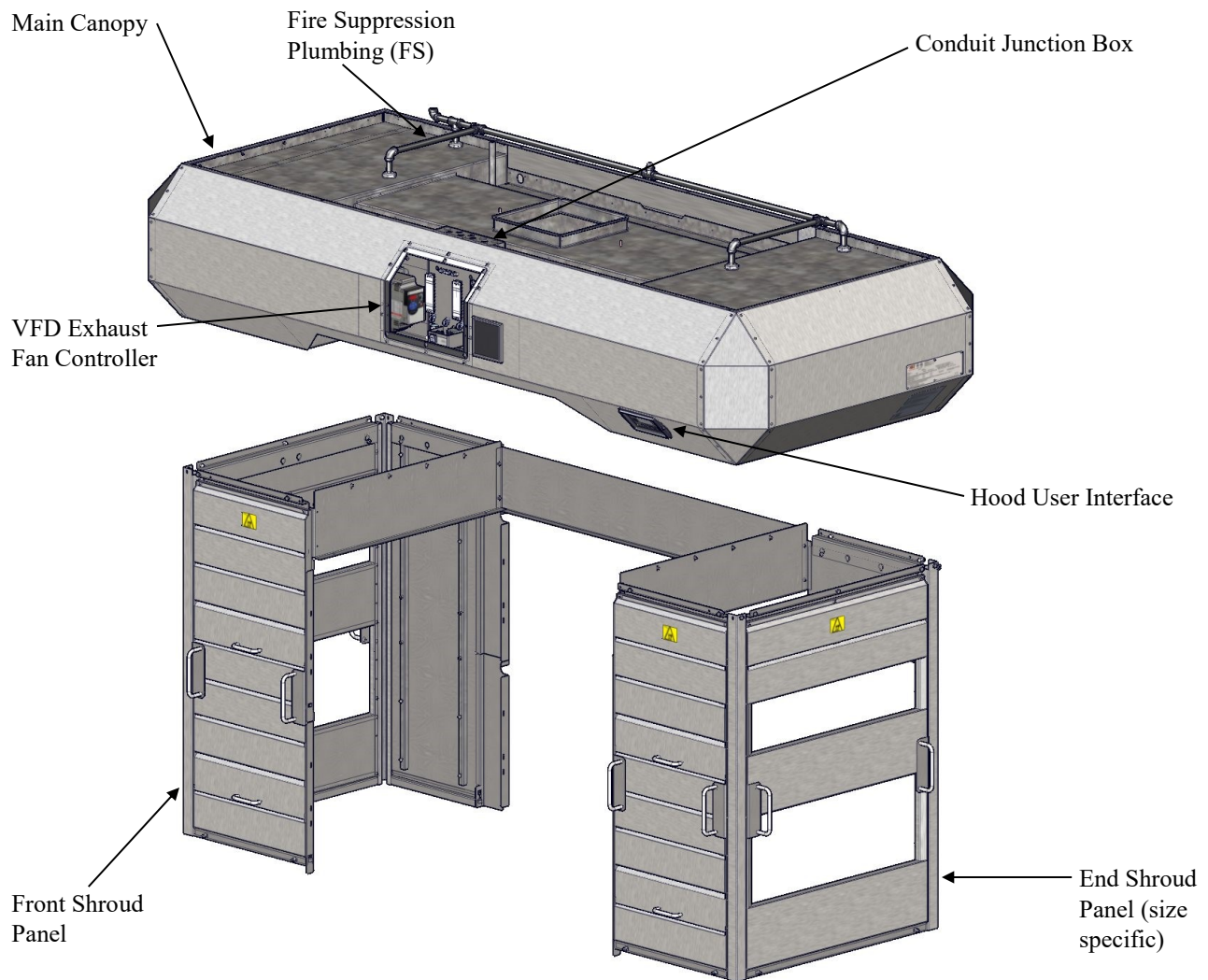

The XLT Hood System consists of three (3) major parts; the Main Canopy, the Shrouds, and the Variable Frequency Drive (VFD) exhaust fan controller.

The Main Canopy serves to collect and transmit heat to the exhaust fan. It houses filters, lights, and the controller. The controller operates both the hood and ovens. The main canopy size is dependent upon oven size.

The Shrouds assist the efficiency of the main canopy by entrapping heat. They are configurable for either front or end loading and front or end unloading, and are easily removable for cleaning and maintenance.

The VFD converts input power to variable frequency three-phase output power to control the speed of the exhaust fan. All electric utilities for the hood and exhaust fan connect through the electrical box located on the front of main canopy. The capacitive touch buttons are located on the Hood User Interface on the front of main canopy, and interlock the power function of the hood and oven(s). There are relays that provide interlocks for equipment such as, HVAC dampers, and/or dedicated MUA units and there is an optional relay for fire suppression.

All XLT hoods are available pre-piped for fire suppression, allowing for simple, in-field installations. For fire suppression detailed information see manual XD-9011 Fire Suppression Installation for XLT Hoods and XLT Ovens.

The XLT hood was designed to conform to the requirements of IMC 2015 or current version, which is a Type I hood. It was also designed to have optional fire suppression added to meet requirements of NFPA 96 standard. This was done to allow XLT to better service the requirements of the customer and the associated jurisdictions.

DOMESTIC HOOD CRATES

Hood Crate Dimensions			
Oven Model	X	Y	Z (With Hood)
1832	115 3/4 [2940]	31 3/4 [806]	47 1/4 [1198]
2440	115 3/4 [2940]	31 3/4 [806]	53 1/4 [1351]
3240	115 3/4 [2940]	31 3/4 [806]	61 1/4 [1554]
3255	132 3/4 [3372]	31 3/4 [806]	61 1/4 [1554]
3855	132 3/4 [3372]	31 3/4 [806]	67 1/4 [1706]
3270	132 3/4 [3372]	31 3/4 [806]	61 1/4 [1554]
3870	132 3/4 [3372]	31 3/4 [806]	67 1/4 [1706]

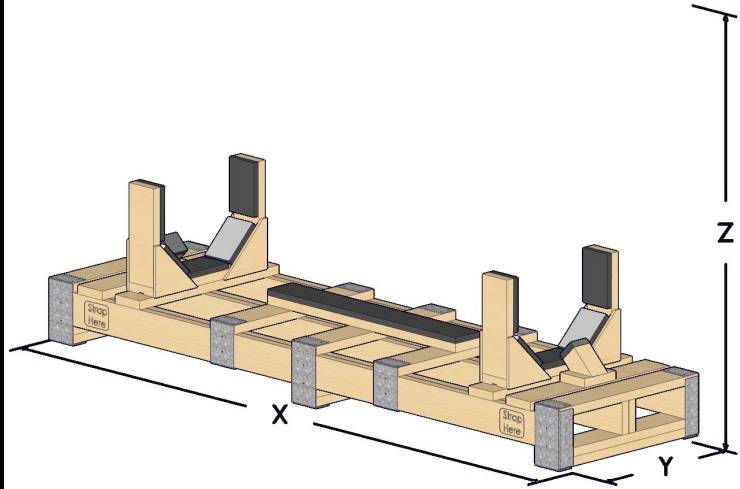

INTERNATIONAL HOOD CRATES

Hood Crate Dimensions			
Oven Model	X	Y	Z
xx32	94 1/4 [2394]	27 [686]	61 1/4 [1556]
xx40	102 1/4 [2597]	27 [686]	64 3/8 [1635]
xx55	117 1/4 [2978]	27 [686]	72 3/8 [1838]
xx70	132 1/4 [3359]	27 [686]	72 3/8 [1838]

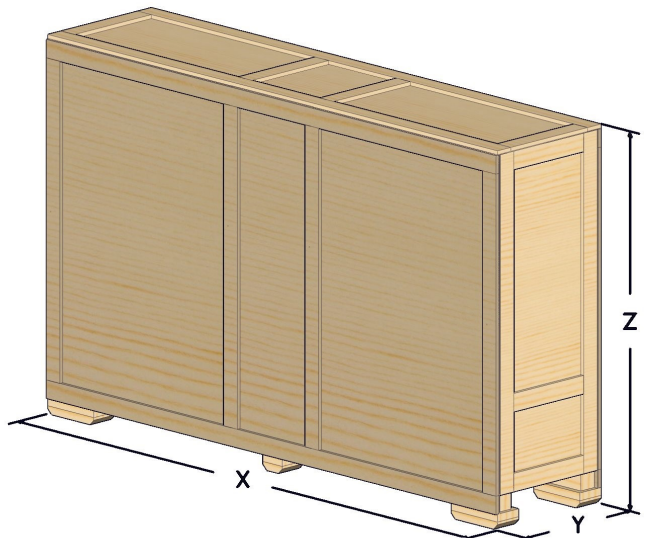

NOTE: All dimensions in inches [millimeters], ± 1/4 [6], unless otherwise noted.

SHROUD CRATES

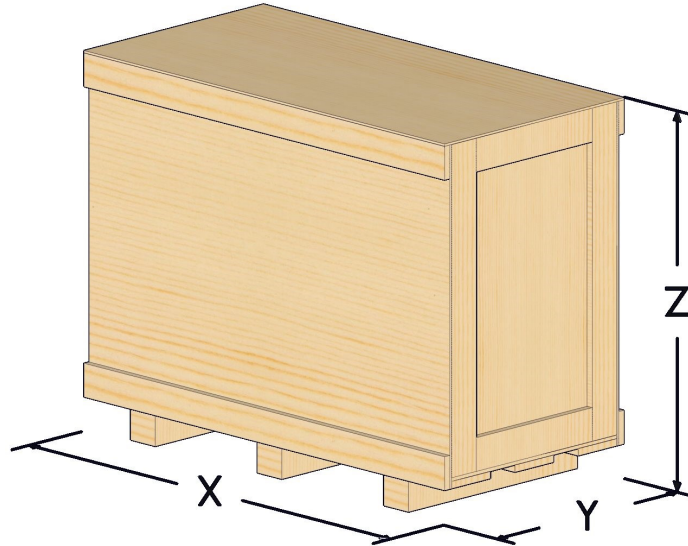

Shroud Crate Dimensions			
Oven Model	X	Y	Z
18xx-1	51 1/4	25 1/2	27 1/2
18xx-2	[1302]	[648]	[699]
18xx-3	66 1/4 [1683]	25 1/2 [648]	27 1/2 [699]
24xx-1	51 1/4	25 1/2	31 1/2
24xx-2	[1302]	[648]	[800]
24xx-3	66 1/4 [1683]	25 1/2 [648]	31 1/2 [800]

Shroud Crate Dimensions			
Oven Model	X	Y	Z
32xx-1	51 1/4	25 1/2	39 1/2
32xx-2	[1302]	[648]	[1003]
32xx-3	66 1/4 [1683]	25 1/2 [648]	39 1/2 [1003]
38xx-1	51 1/4	25 1/2	45 1/2
38xx-2	[1302]	[648]	[1156]
38xx-3	66 1/4 [1683]	25 1/2 [648]	45 1/2 [1156]

NOTE: All dimensions in inches [millimeters], ± 1/4 [6], unless otherwise noted.

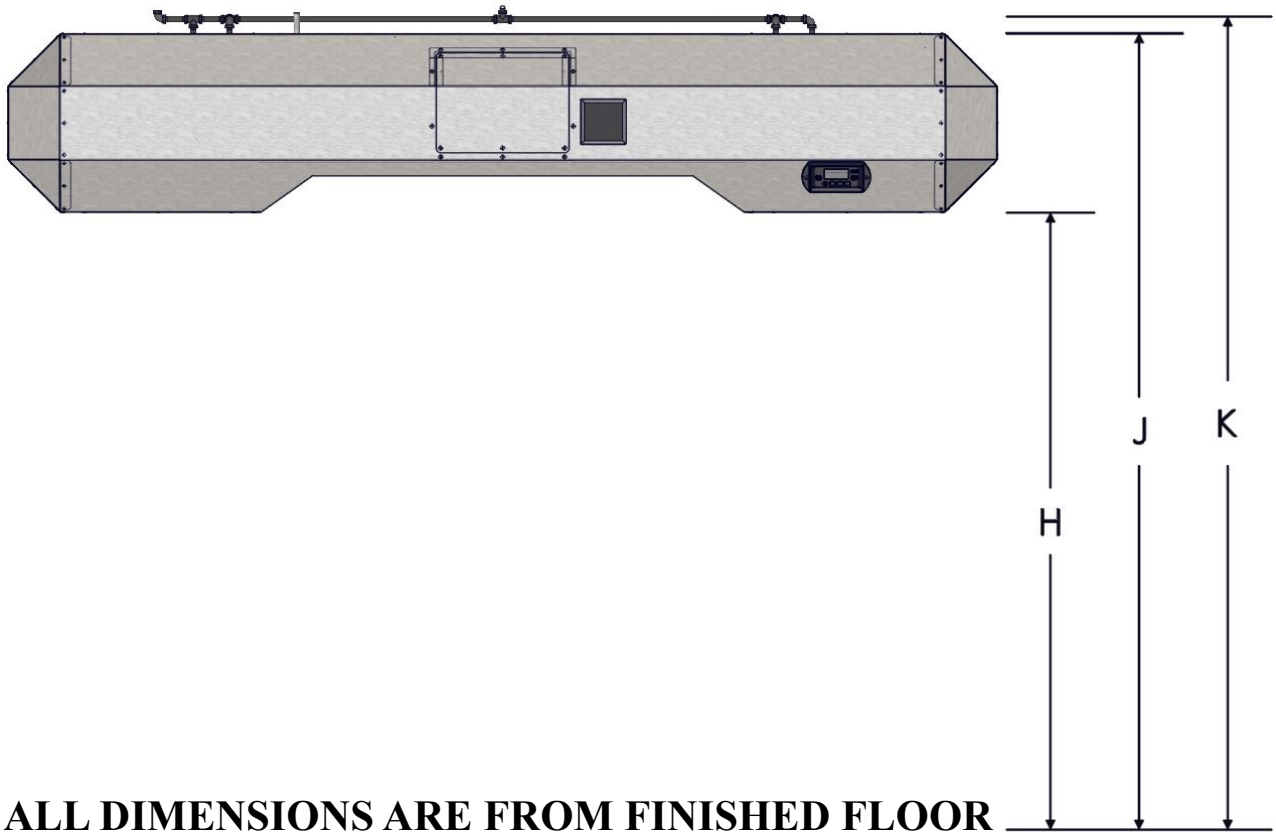
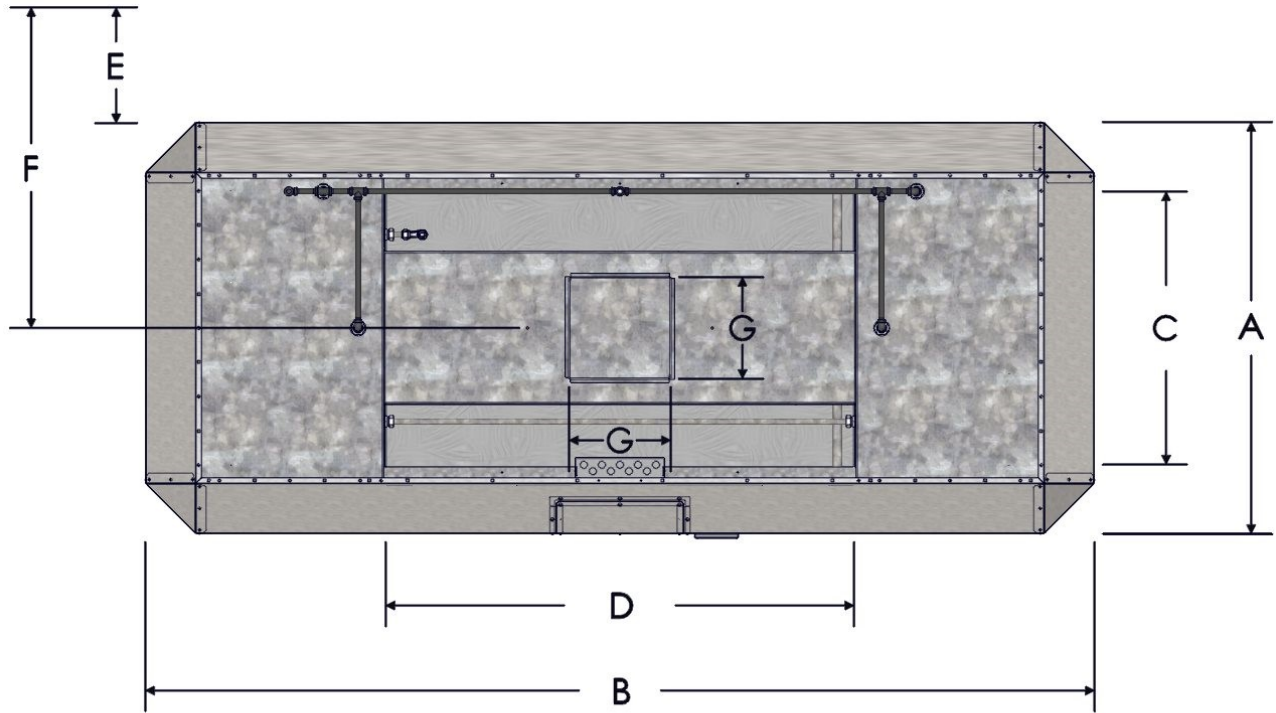

ALL DIMENSIONS ARE FROM FINISHED FLOOR

Oven Model	Hood Dimensions										Hood With Shrouds Weights			Crated Weight (2 Crates)			
	A	B	C	D	E*	F*	G	H	J	K	Single	Double	Triple	Hood	Single	Double	Triple
1832	34 3/8 [873]	88 5/8 [2251]	18 [457]	32 [813]	13 1/2 [343]	30 5/8 [778]	12	69 5/8 ±1/8	89 7/8	91 7/8 [2334]	506 [230]	495 [225]	495 [225]	523 [237]	310 [141]	264 [120]	304 [138]
2440	40 3/8 [1026]	96 5/8 [2454]	24 [610]	40 [1016]		33 5/8 [854]					590 [268]	565 [256]	560 [254]	610 [277]	339 [154]	281 [127]	322 [146]
3240	48 3/8 [1229]	96 5/8 [2454]	32 [813]	40 [1016]		37 5/8 [956]					685 [311]	640 [290]	660 [299]	661 [300]	373 [169]	304 [138]	333 [151]
3255	48 3/8 [1229]	111 5/8 [2835]	32 [813]	55 [1397]		37 5/8 [956]					735 [333]	680 [308]	700 [318]	724 [328]	385 [175]	310 [141]	333 [151]
3270	48 3/8 [1229]	126 5/8 [3216]	32 [813]	70 [1778]		37 5/8 [956]					760 [345]	705 [320]	737 [334]	782 [355]	391 [177]	304 [138]	328 [149]
3855	54 3/8 [1381]	111 5/8 [2835]	38 [965]	55 [1397]		40 5/8 [1032]					795 [361]	730 [331]	745 [338]	764 [347]	408 [185]	310 [141]	339 [154]
3870	54 3/8 [1381]	126 5/8 [3216]	38 [965]	70 [1778]		40 5/8 [1032]					825 [374]	770 [349]	770 [349]	828 [376]	419 [190]	322 [146]	345 [156]

Exhaust Fan And Curb Dimensions			Crated Weight (Stacked)
31 [787]	31 [787]	67 [1702]	185 [84]



NOTE

* E and F are the minimum distances from a non combustible wall structure.

NOTE: All dimensions in inches [millimeters], ± 1/4 [6], unless otherwise noted.
All weights in pounds [kilograms] unless otherwise noted.

Exhaust Flow Rates VOLUME (min. recommended)								
		Ovens On			18xx	24xx	32xx	38xx
		Top	Middle	Bottom				
Single	X				500	500	500	500
					[14.16]	[14.16]	[14.16]	[14.16]
Double	X				500	500	500	500
					[14.16]	[14.16]	[14.16]	[14.16]
	X		X		506	644	828	966
					[14.33]	[18.24]	[23.45]	[27.35]
Triple	X				500	500	500	500
					[14.16]	[14.16]	[14.16]	[14.16]
	X	X			506	644	828	966
					[14.33]	[18.24]	[23.45]	[27.35]
	X		X		766	975	1254	1463
					[21.69]	[27.61]	[35.51]	[41.43]
	X	X	X		506	644	828	966
					[14.33]	[18.24]	[23.45]	[27.35]
X		X	X	766	975	1254	1463	
				[21.69]	[27.61]	[35.51]	[41.43]	
X	X	X	X	766	975	1254	1463	
				[21.69]	[27.61]	[35.51]	[41.43]	

**NOTE**

All values are CFM [M3/Min] unless otherwise noted. Figures represent TOTAL VOLUME measured at the duct.

In accordance with mechanical codes, make up air must be supplied. For commercial kitchen make up air, the amount is determined by the exhaust hood flow rate requirements & all other exhaust flow rate requirements in the kitchen.

At a minimum, smoke candles must be used for a Capture & Containment (C&C) test. Refer to the Ventilation Requirements disclosed in the Oven section in this manual.

A Test & Balance (TAB) report is recommended after installation has been completed. Below are the minimum items to be included in this report:

- Total airflow on all A/C, Make-Up Air (MUA), & exhaust systems.
- Airflow on each supply & exhaust grille.
- Airflows on exhaust hoods compared to design specifications.

A final air balance report, with any corrections of issues found in the report, will help to insure that your building systems are functioning properly & efficiently.

[Refer to “Oven Ventilation Requirements & Guidelines”](#)

Exhaust Flow Rates VELOCITY (min. recommended)								
		Ovens On			18xx	24xx	32xx	38xx
		Top	Middle	Bottom				
Single	X				187.5	187.5	93.75	93.75
					[57.15]	[57.15]	[28.58]	[28.58]
Double	X				187.5	187.5	93.75	93.75
					[57.15]	[57.15]	[28.58]	[28.58]
	X		X		189.75	241.5	155.25	181.125
					[57.84]	[73.61]	[47.32]	[55.21]
Triple	X				187.5	187.5	93.75	93.75
					[57.15]	[57.15]	[28.58]	[28.58]
	X	X			189.75	241.5	155.25	181.125
					[57.84]	[73.61]	[47.32]	[55.21]
	X		X		287.25	365.625	235.125	274.3125
					[87.55]	[111.44]	[71.67]	[83.61]
	X	X			189.75	241.5	155.25	181.125
					[57.84]	[73.61]	[47.32]	[55.21]
X		X		287.25	365.625	235.125	274.3125	
				[87.55]	[111.44]	[71.67]	[83.61]	
X	X	X		287.25	365.625	235.125	274.3125	
				[87.55]	[111.44]	[71.67]	[83.61]	
X	X	X		287.25	365.625	235.125	274.3125	
				[87.55]	[111.44]	[71.67]	[83.61]	



NOTE

All values are FPM [M/Min] unless otherwise noted. Figures represent VELOCITY measured at the Grease Filter.



NOTE

Verify through building codes what the minimum required CFM velocity is and that it is greater than the values listed in the above table for the size and quantity of ovens in below the hood.

The VELOCITY readings above are obtained by holding an anemometer 3” away from the Grease Filter. Take several readings in different locations across the filters and average the results.

Inputs into Electrical

XLT Hood Electric Utility Specifications			
	# of Circuits	Rating	Purpose
Standard	1	208/240 VAC, 1 Phase, 60 Hz, 6 Amp	VFD Controller
	up to 3	120 VAC, 1 Phase, 60 Hz, 20 Amp	Ovens
World	1	230 VAC, 1 Phase, 50 Hz, 6 Amp	VFD Controller
	up to 3	230 VAC, 1 Phase, 50 Hz, 10 Amp	Ovens



CAUTION

Do not connect to 3 Phase power. 1 Phase Only.

Outputs from Electrical

The XLT Hood system provides:

- Up to three (3) switching outputs for HVAC damper and/or dedicated unit.
- One (1) 230 VAC, 10 Amp, variable frequency, three phase power output for the ventilation exhaust fan.
- Up to three (3) receptacles for ovens.
- One (1) 24 VDC fire alarm signal.
- Relocation cord will physically connect into oven.

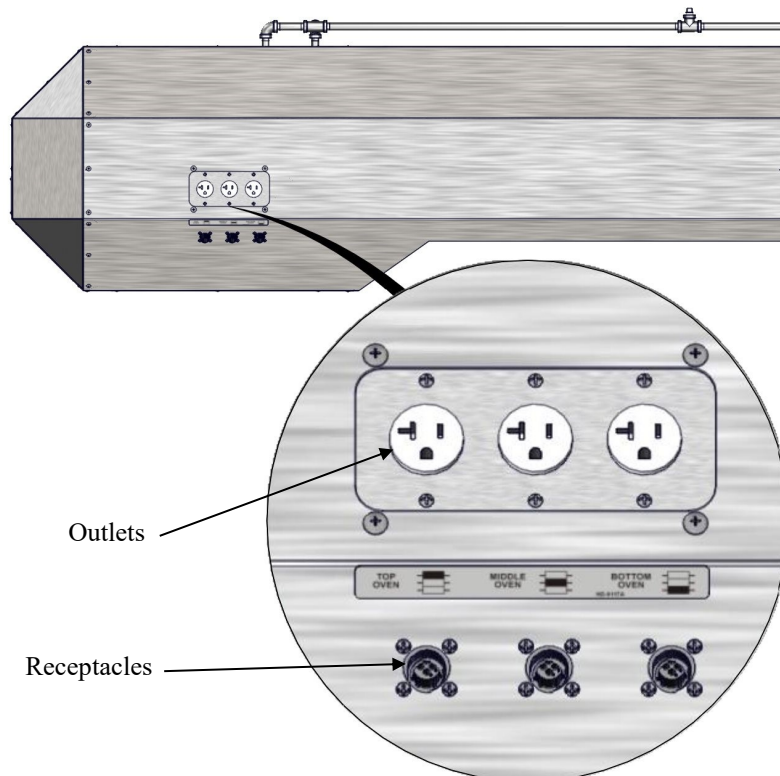

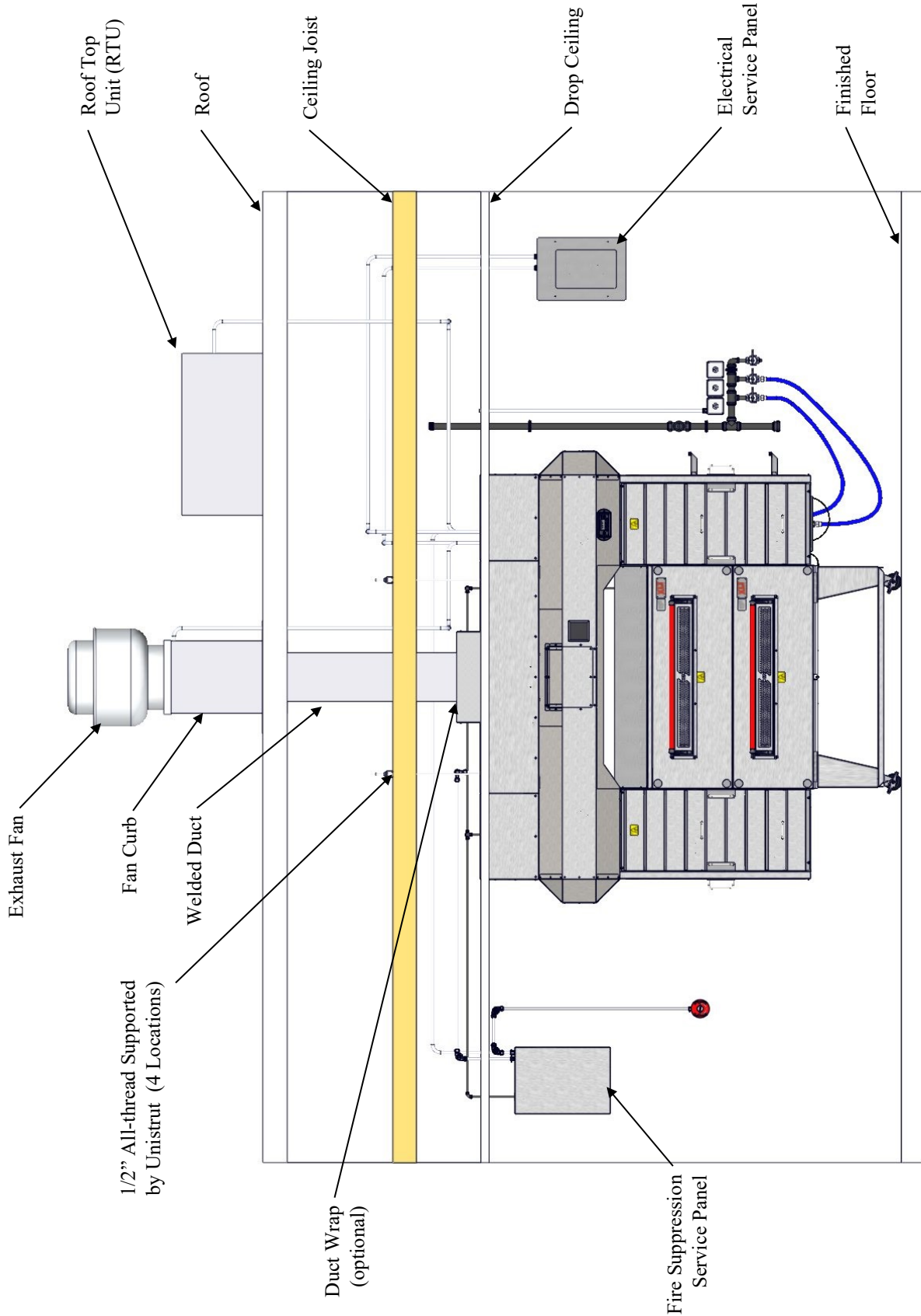

All structural members, electrical & fire suppression equipment shown for reference only.

VFD Control Box

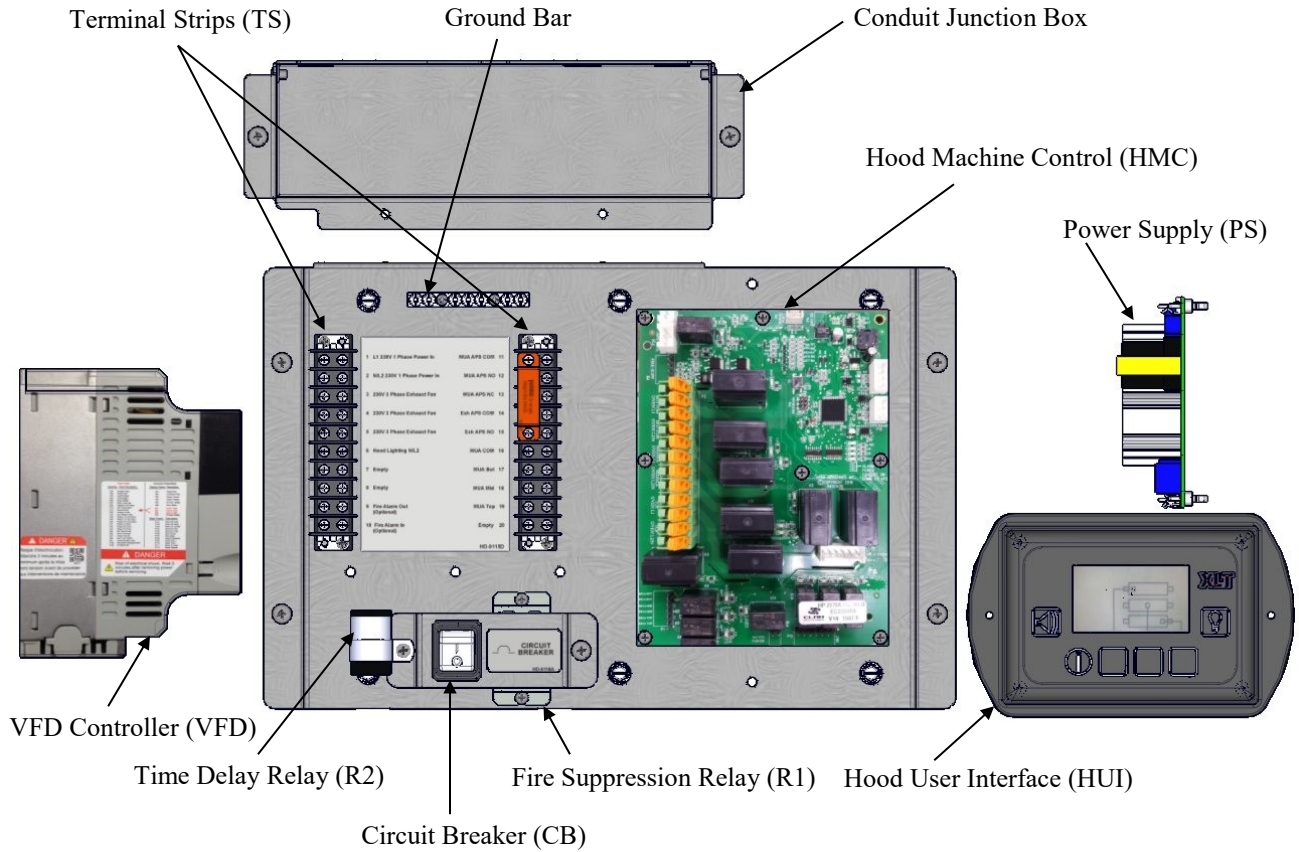

VFD Control Box (Cover removed)

Non VFD Control Box

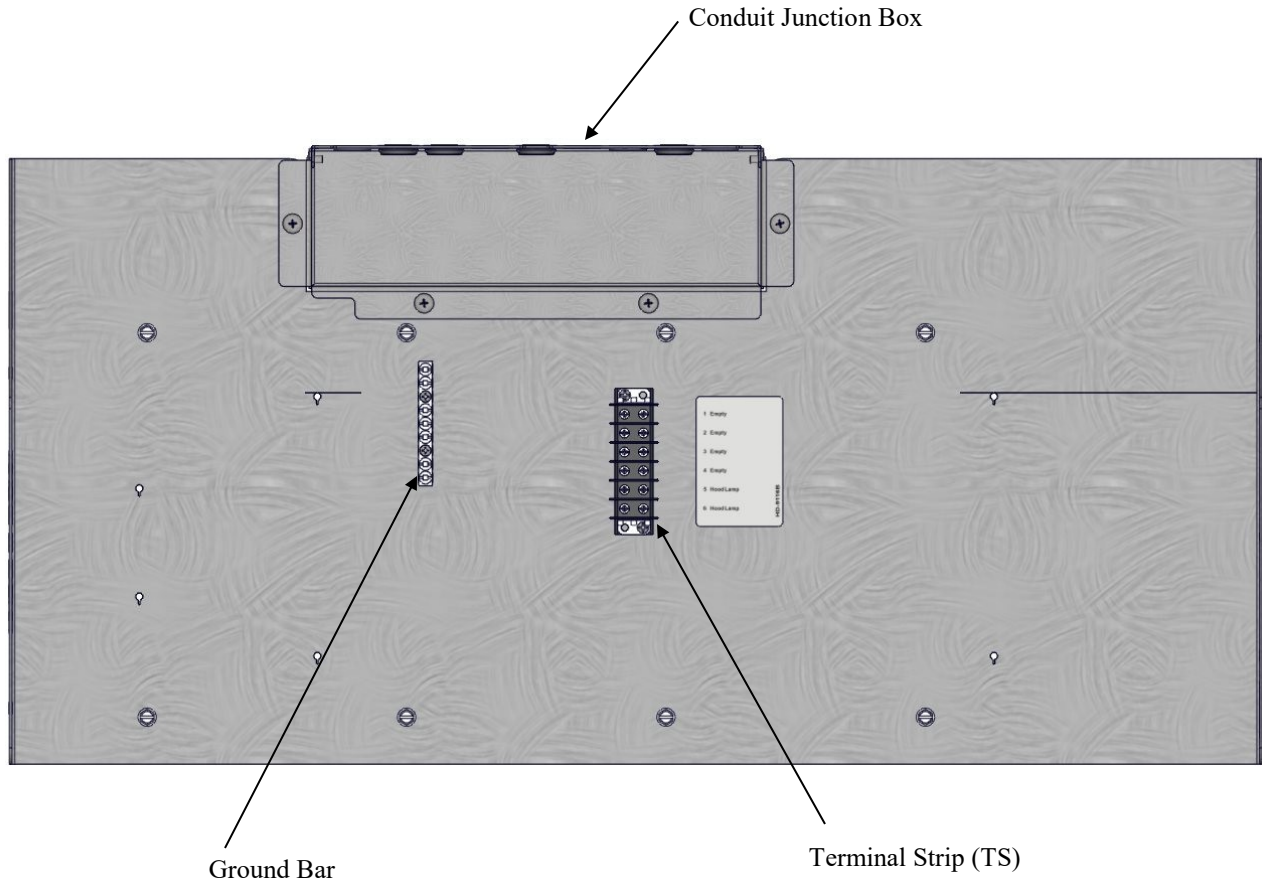

This page is intentionally left blank.

Non VFD Control Box - Input Power To Lights

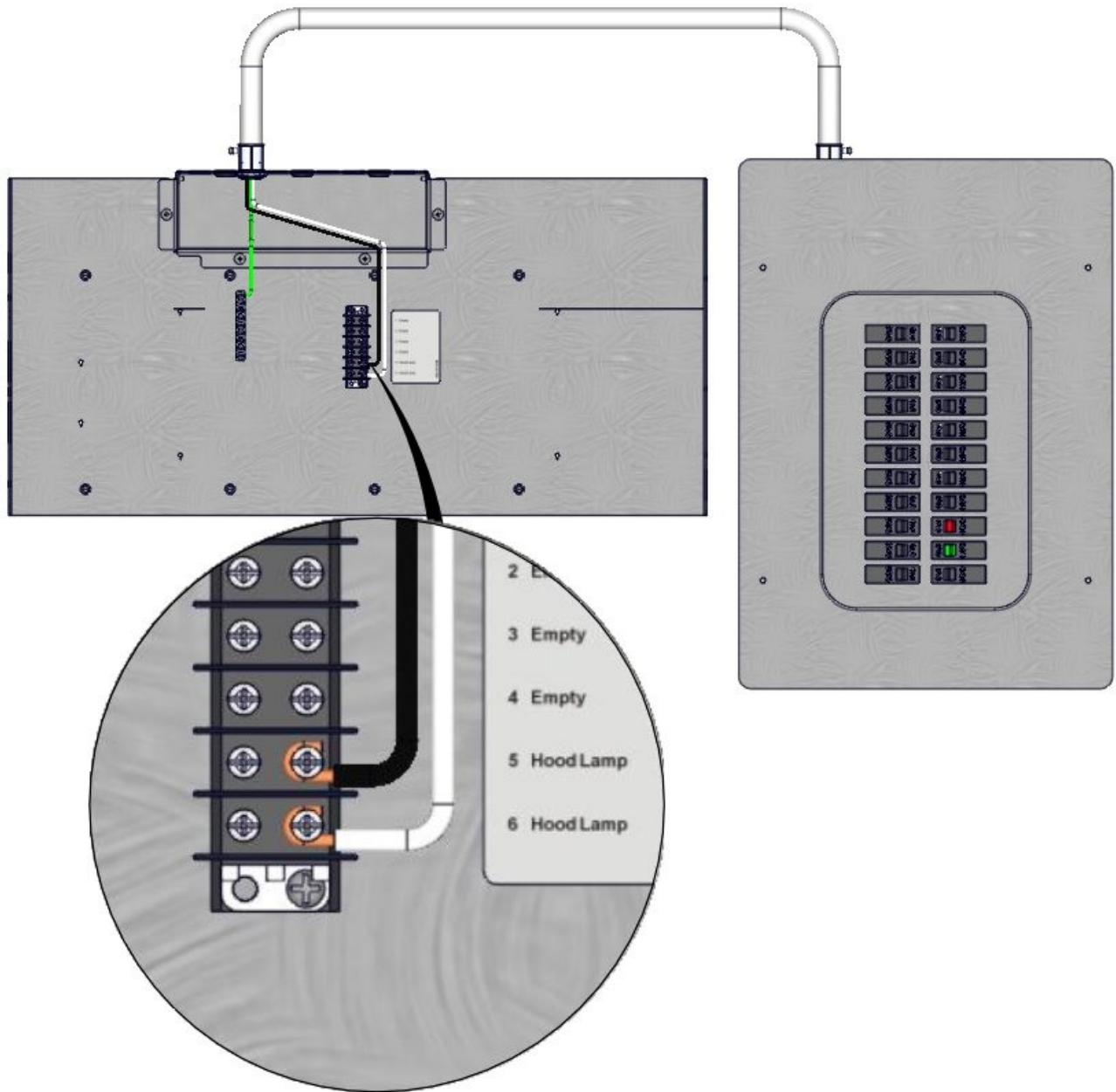

Input Power to Ovens - Standard (120V / 60Hz)

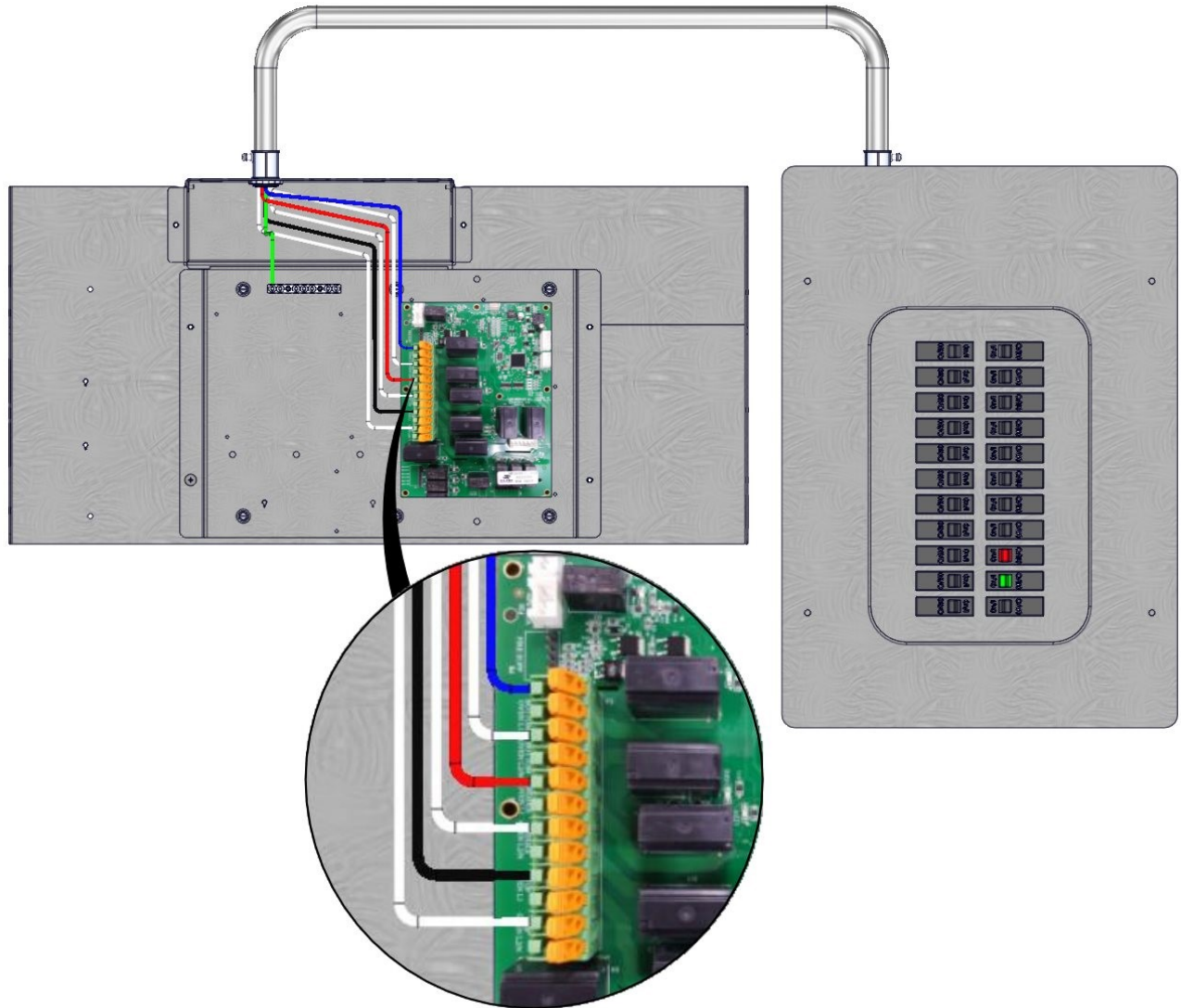
**NOTE**

Each oven will have its own 120V and Neutral wire.

Input Power to Ovens - World (230V / 50Hz)

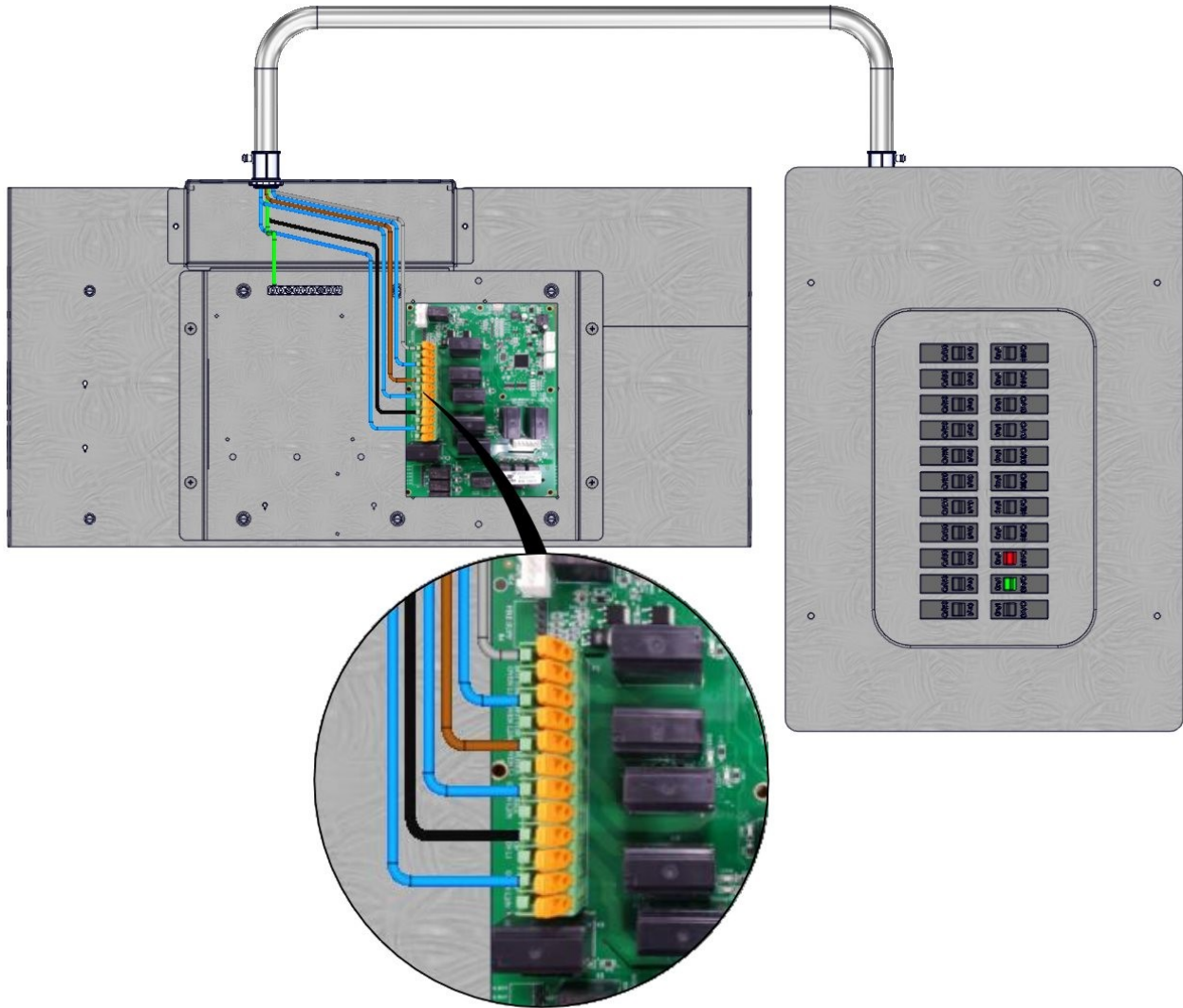

NOTE

Each oven will have its own 230V and Neutral wire.

Input Power to VFD Controller - Standard (208/240V Single Phase)

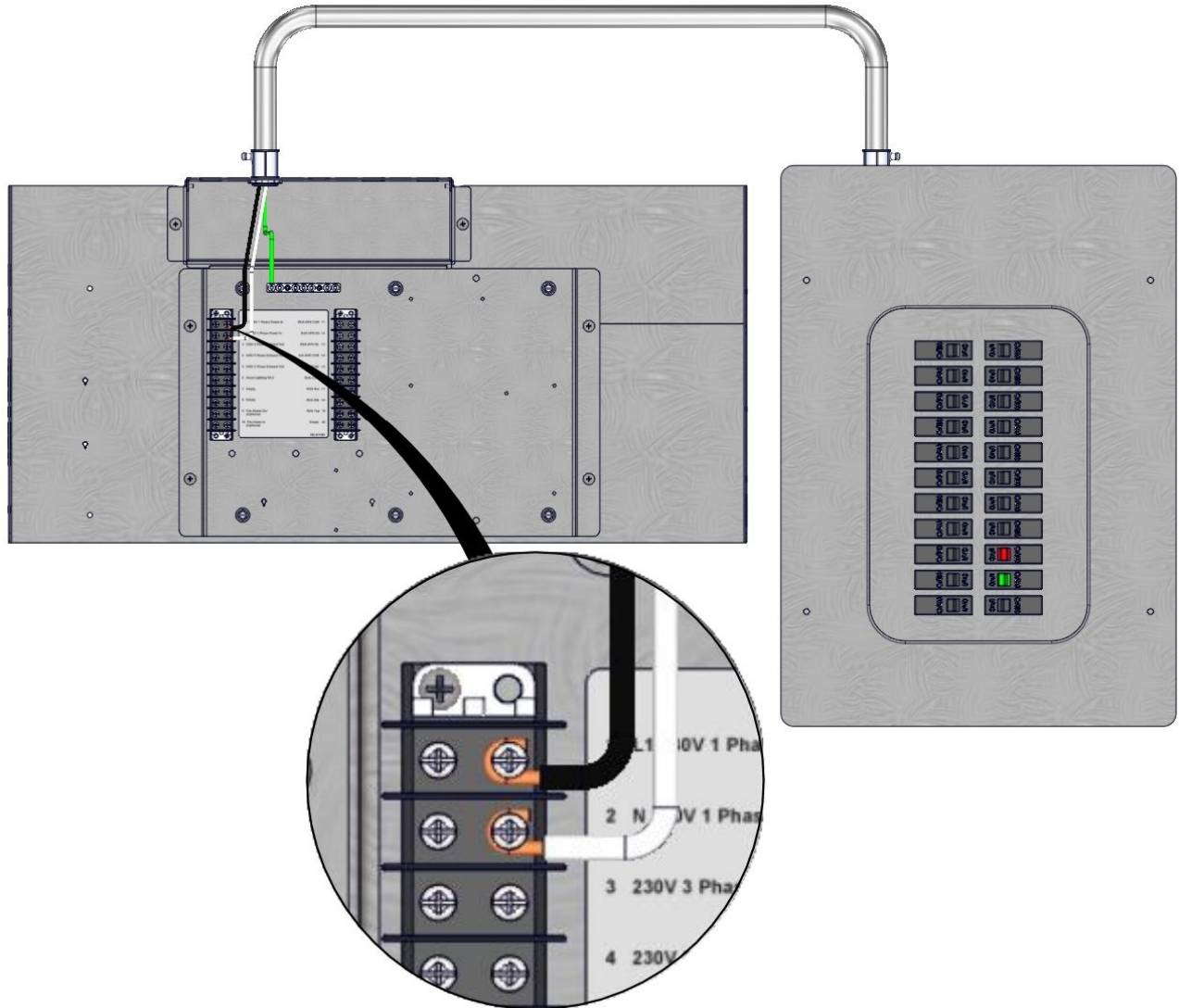

Input Power to VFD Controller - World (230V / 50Hz)

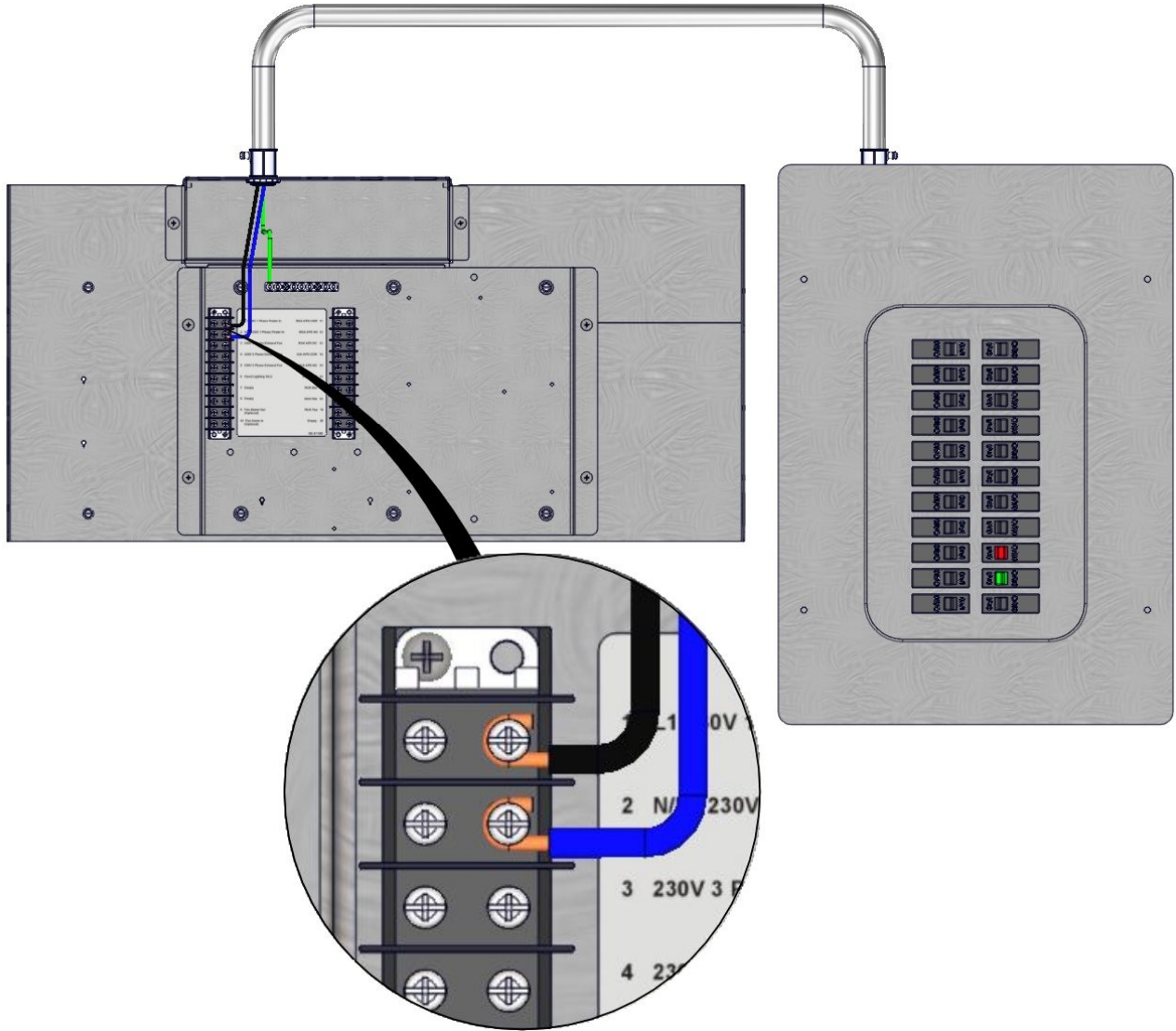

Output Power from VFD to Exhaust Fan - Standard

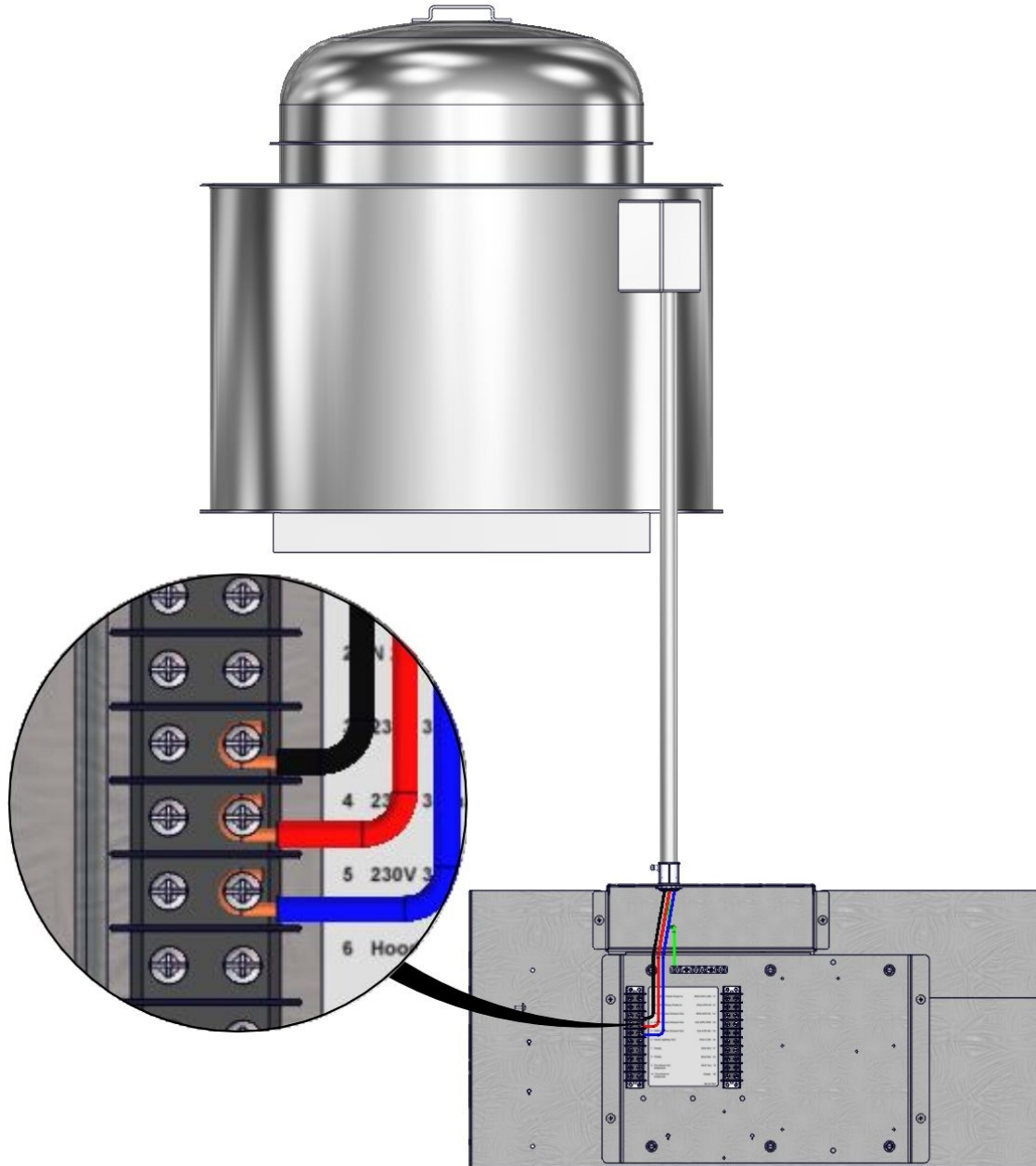

Output Power from VFD to Exhaust Fan - World

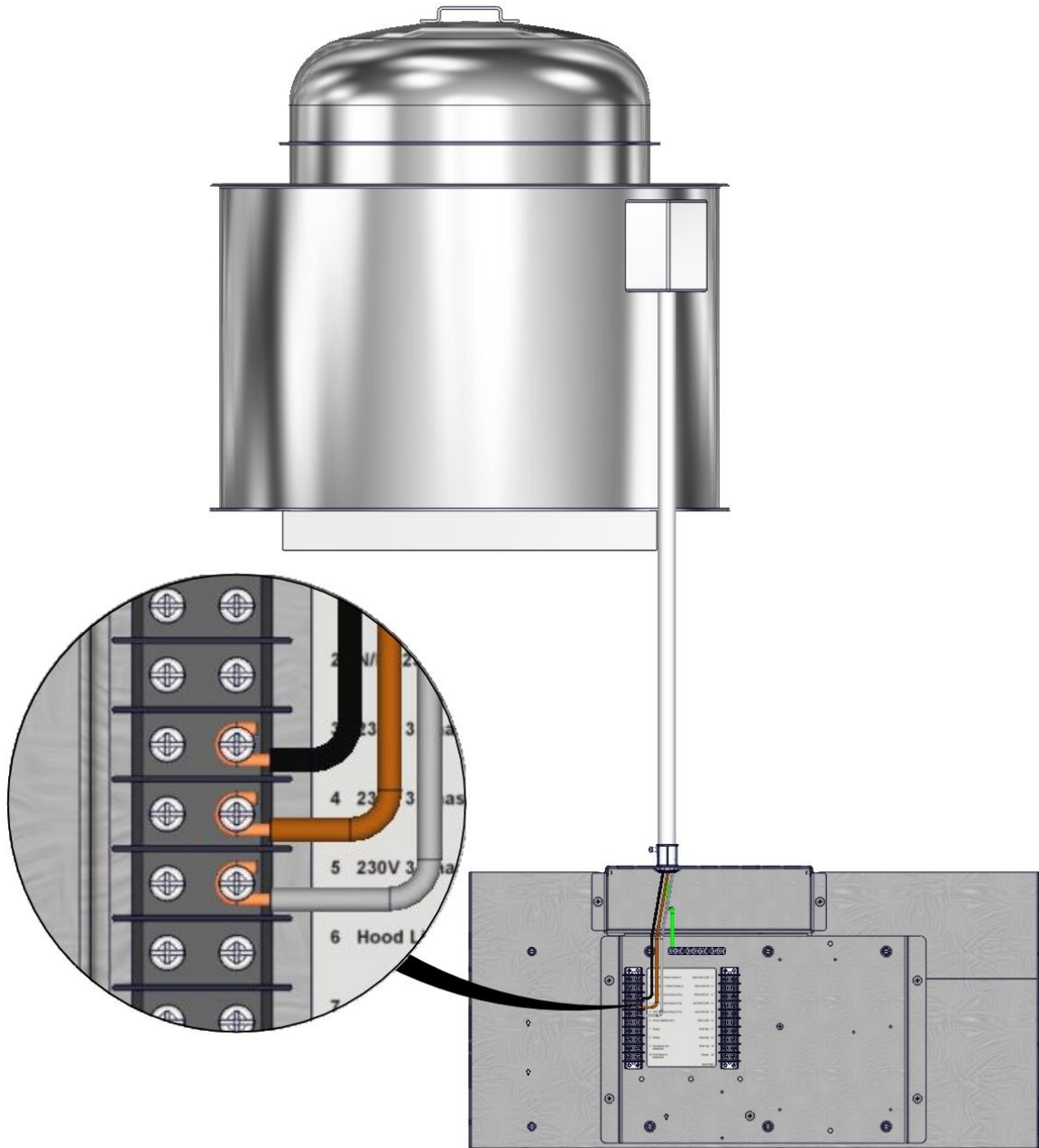

MUA Damper Relays - Single Output - Voltage & Frequency

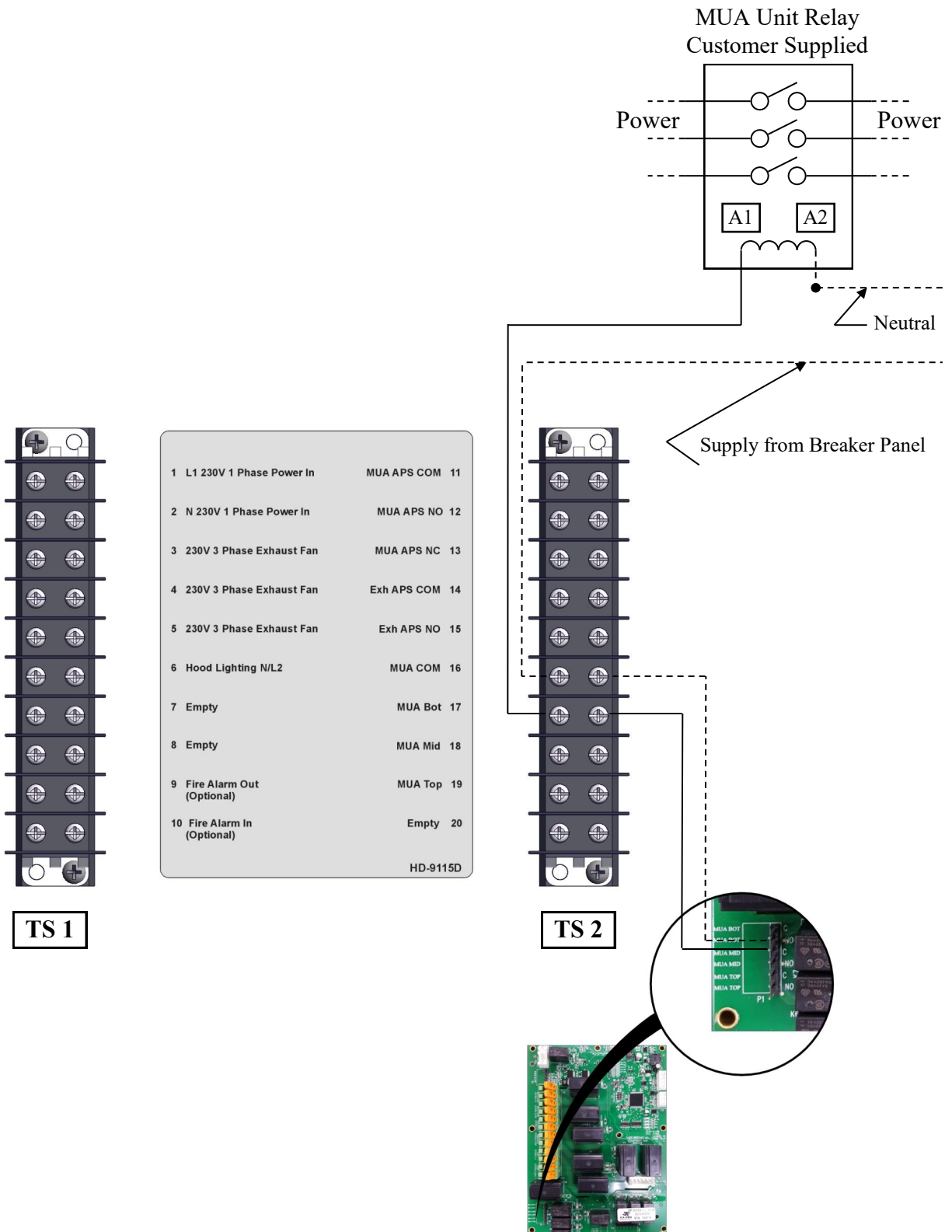

Some wiring removed for clarity. See schematic for details.

MUA Damper Relays - Multiple Output - Voltage & Frequency

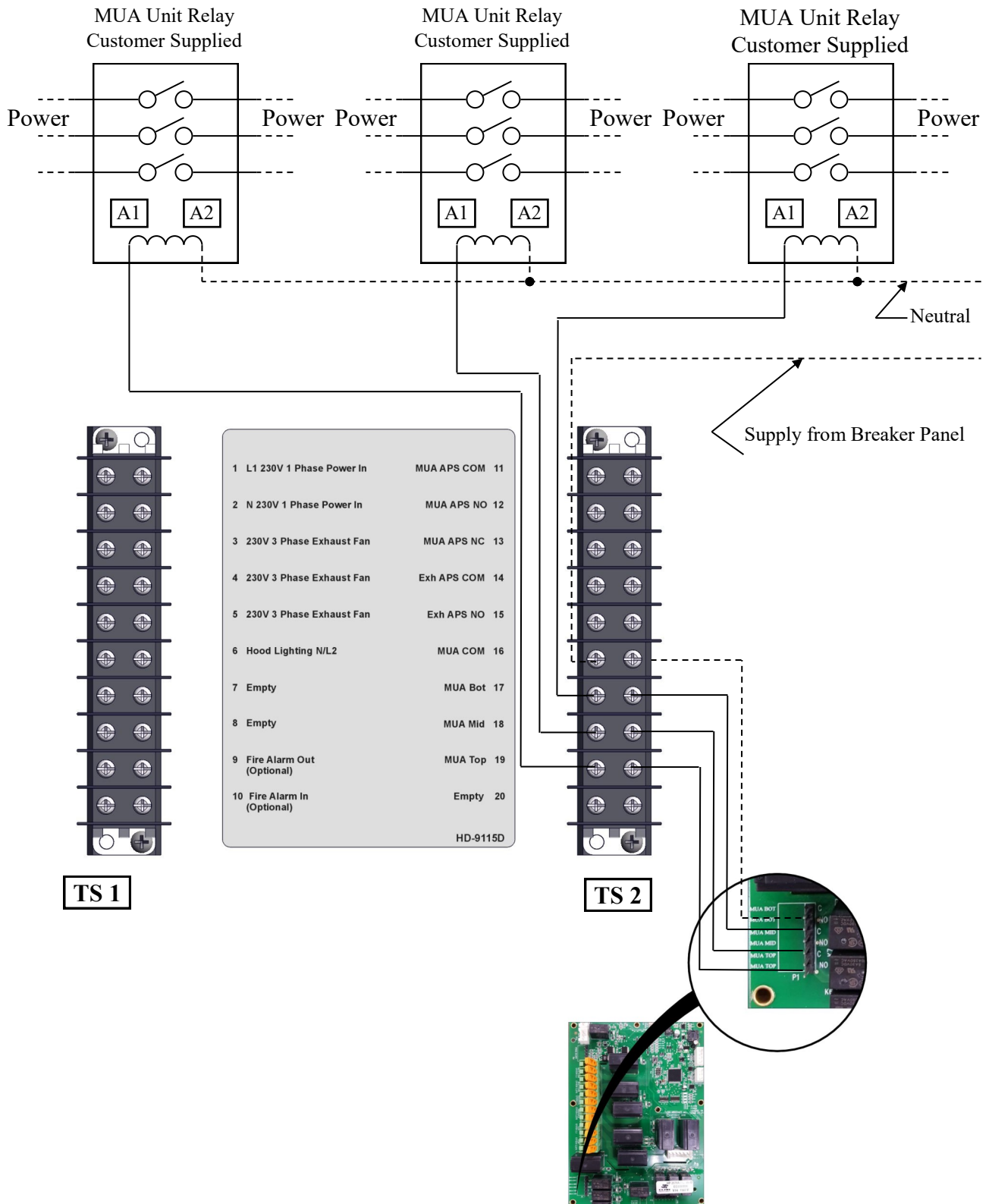

Some wiring removed for clarity. See schematic for details.

World (230V / 50Hz)-W/Air Proving Switches

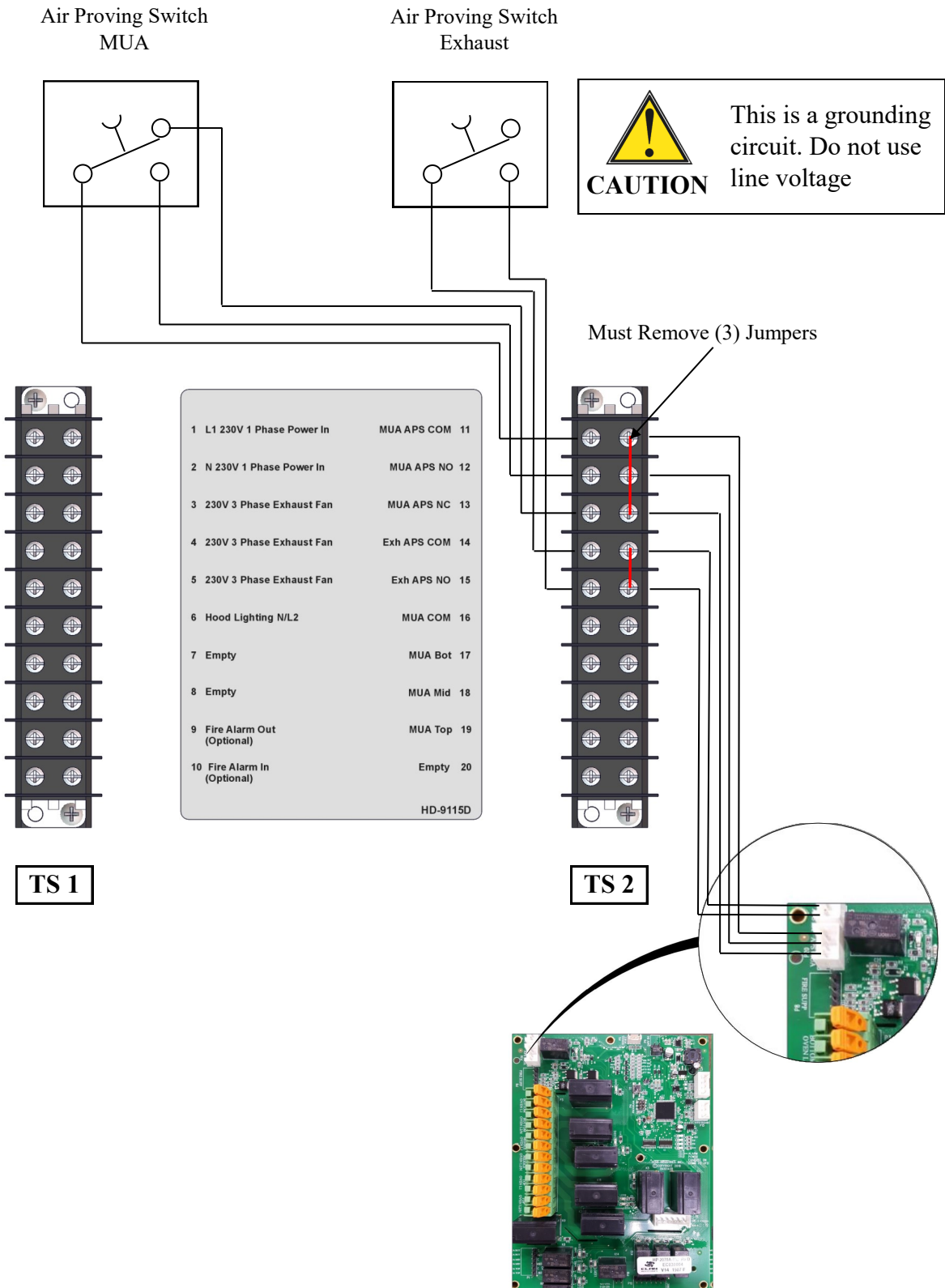

Some wiring removed for clarity. See schematic for details.

Fire Alarm Relay - Voltage & Frequency



Connect wires from the Junction Box to the Normally Open (NO) contacts in the Fire Suppression cabinet.

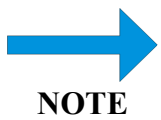
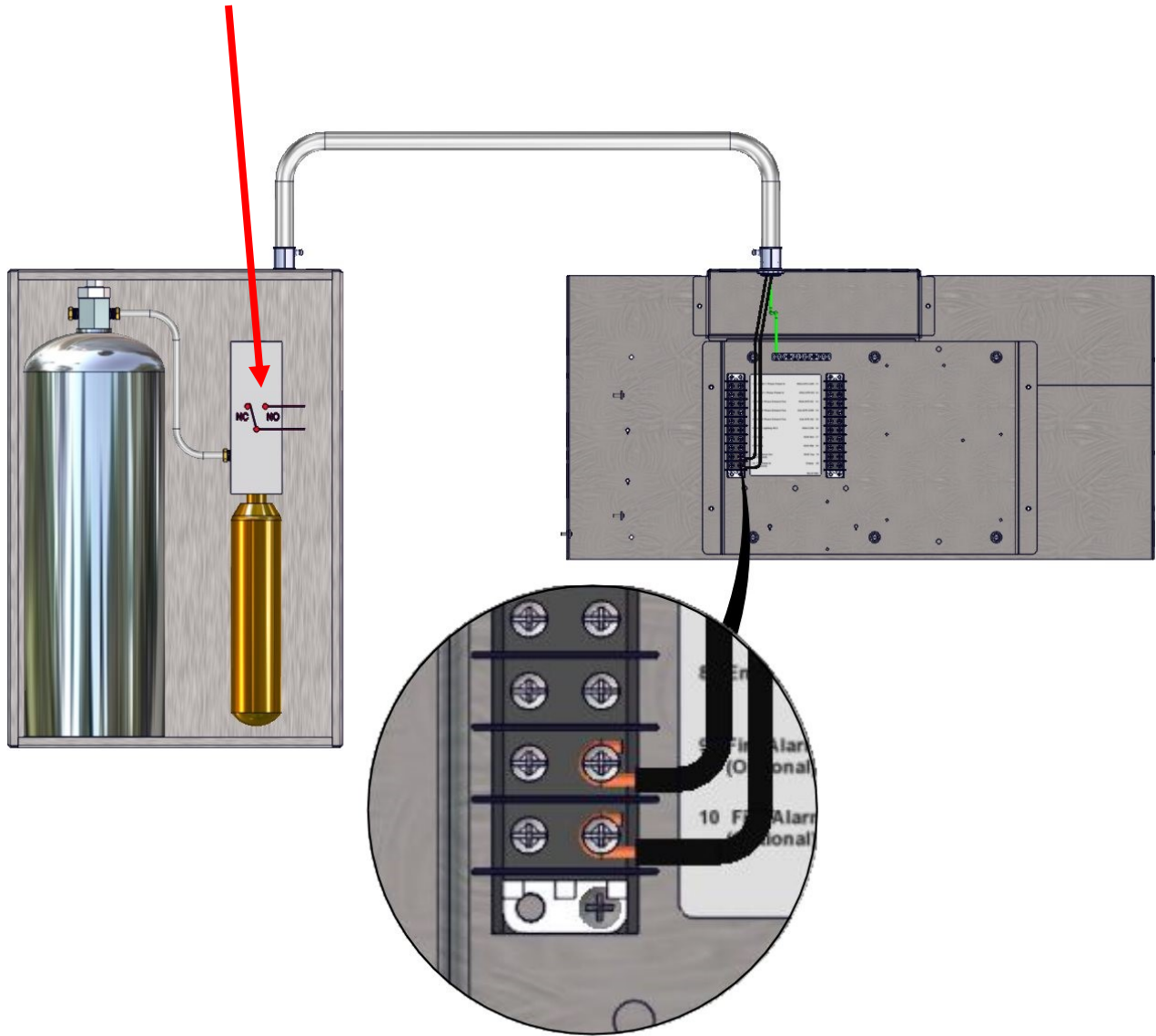

TS1-10R will only have voltage when the Fire Suppression system has been activated.

**DANGER**

Oven must be cool and the electric cord unplugged before hood assembly begins.

**CAUTION**

If the oven is to be removed from its installed location for hood assembly and installation, the following procedure is to be followed:

1. Shut off main manual gas valve
2. Unplug electric cord
3. Unplug gas line
4. Unlock casters
5. Disconnect restraint
6. When hood assembly is complete, move oven to original location
7. Connect restraint
8. Lock casters
9. Connect Relocations cord (if applicable)
10. Plug in electric cord
11. Plug in gas line
12. Turn manual gas valve on
13. Follow normal lighting instructions

**TIP**

Read and understand the next fourteen (14) steps first. They illustrate how to install the components of the hood onto the ovens, and to install the hood.

Prepare Ovens - Remove Lid Screws - Two (2) Only

1

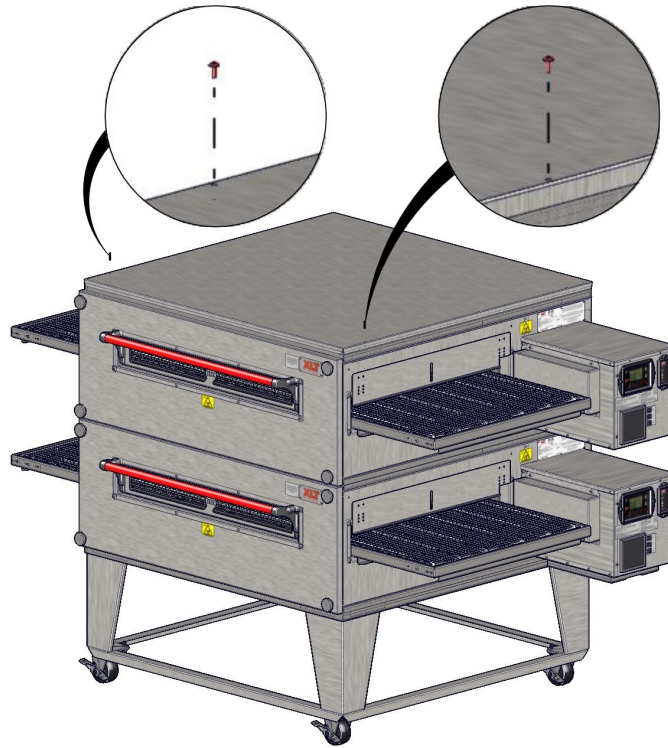

Prepare Ovens - Control Box Closeout Bracket

2



Repeat on other side if the oven(s) are two burner models.



NOTE

Conveyors have been removed for clarity

Prepare Ovens - Front Shroud Brackets

3

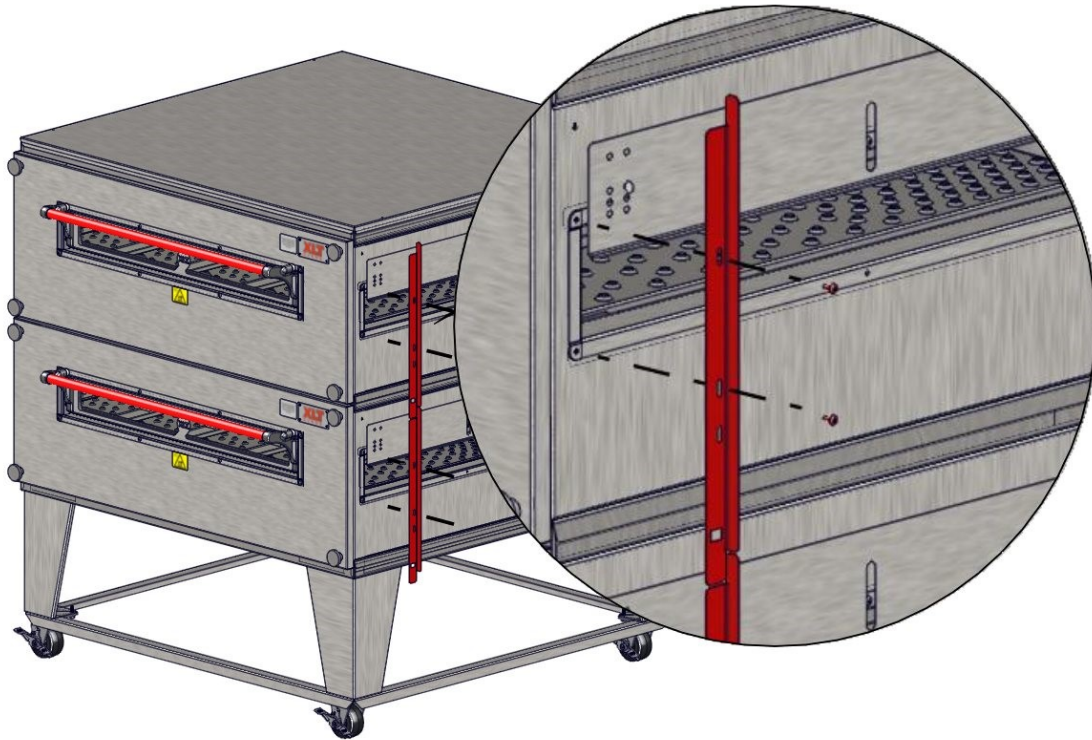

Right Hand Side

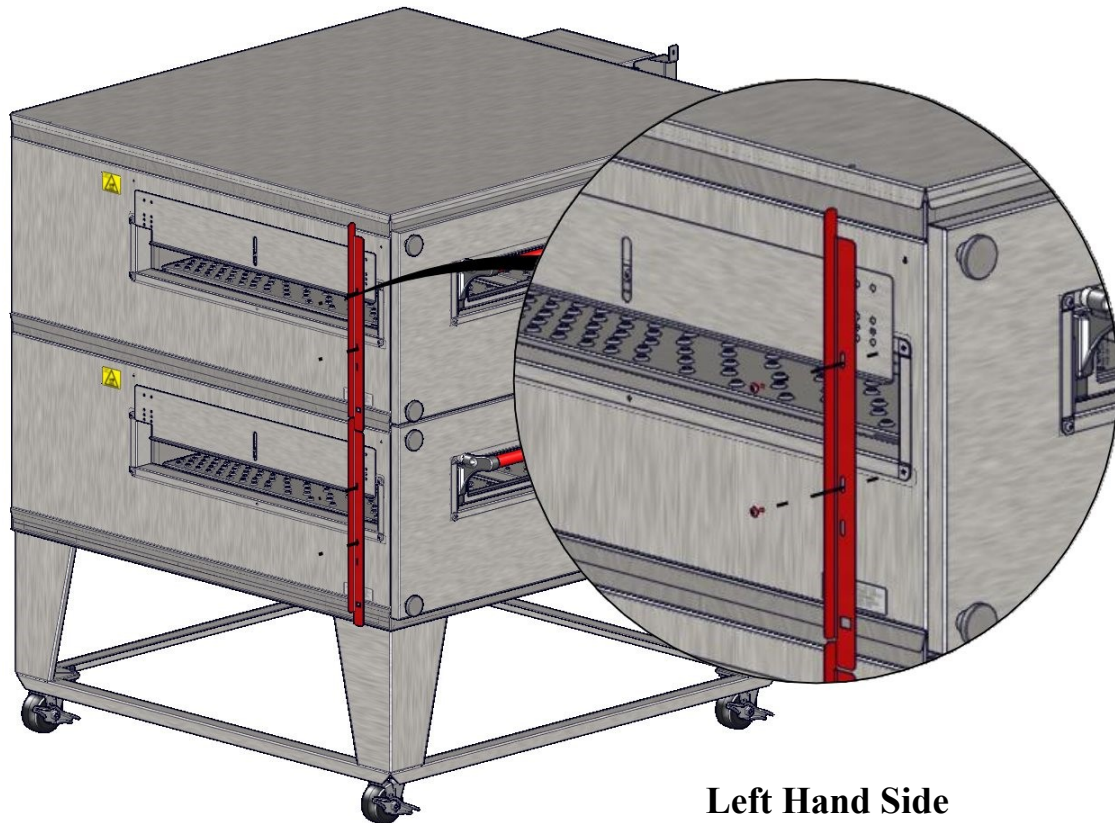

Left Hand Side

Prepare Ovens - Bottom Rail Bracket

4

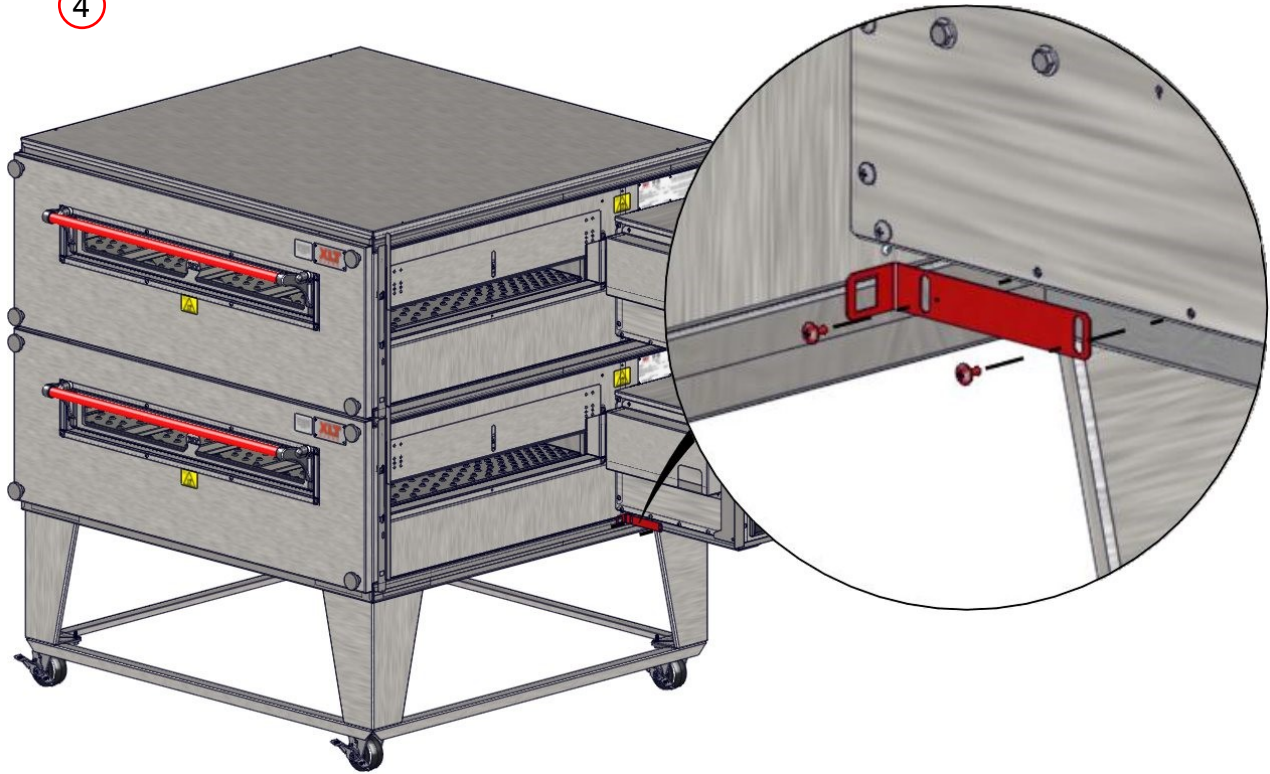

Repeat on other side if the oven(s) are two burner models.

Prepare Ovens - Control Box Side Closeout

5

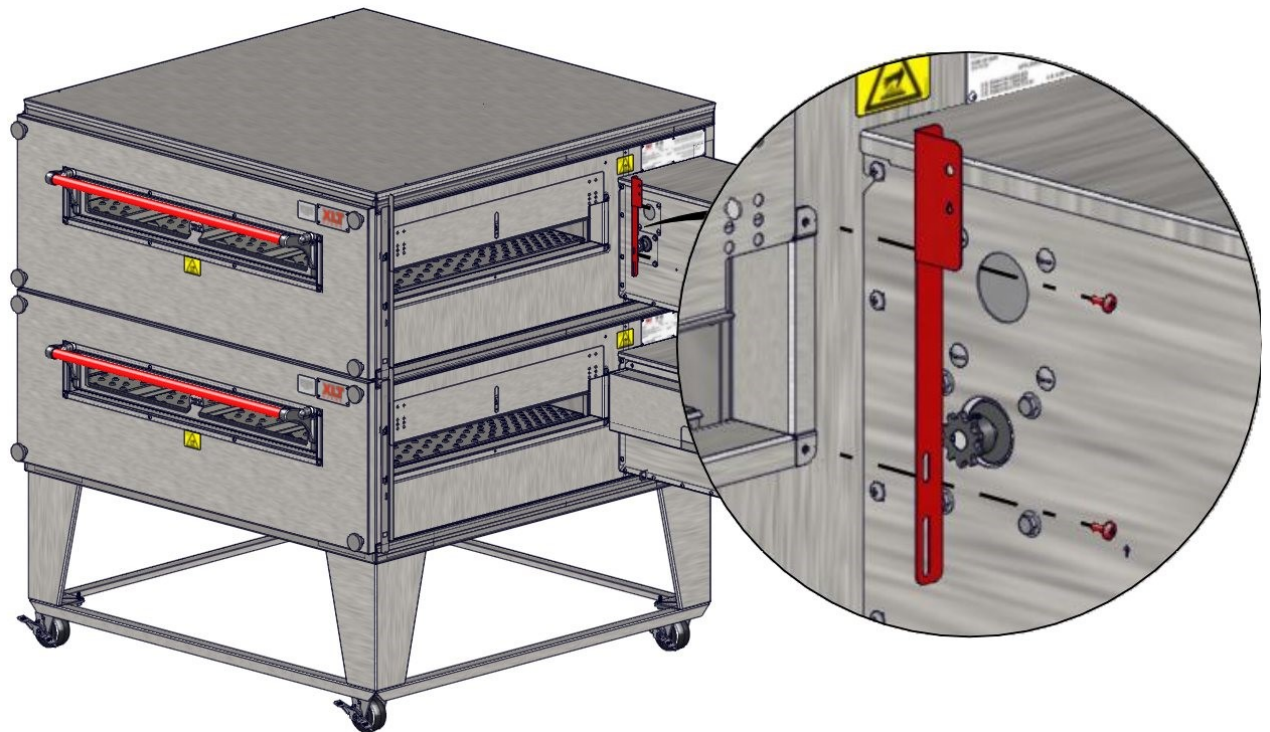

Repeat on other side if the oven(s) are two burner models.

Prepare Ovens - Rear Shroud Brackets

6

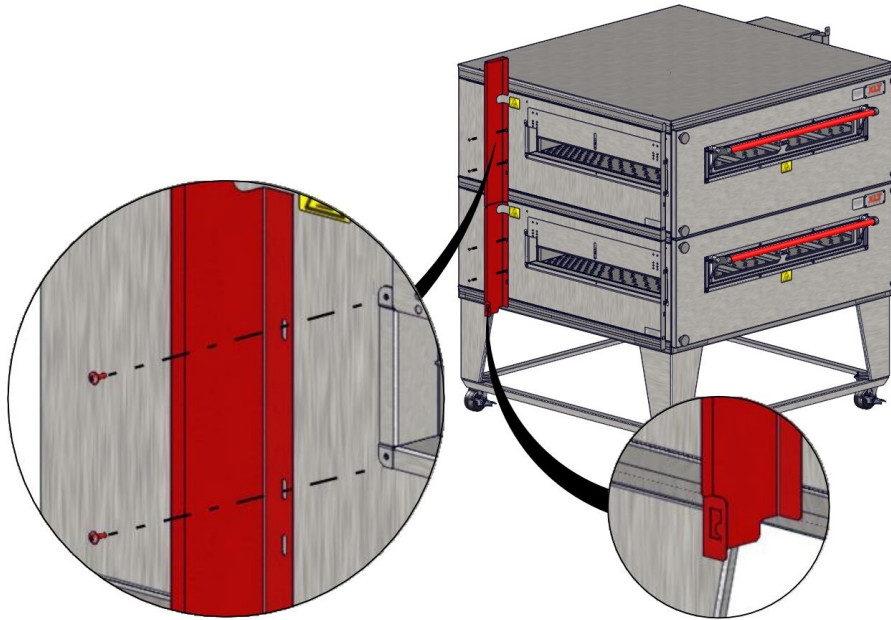

Skip this step if the oven(s) are two burner models.

Prepare Hood

7

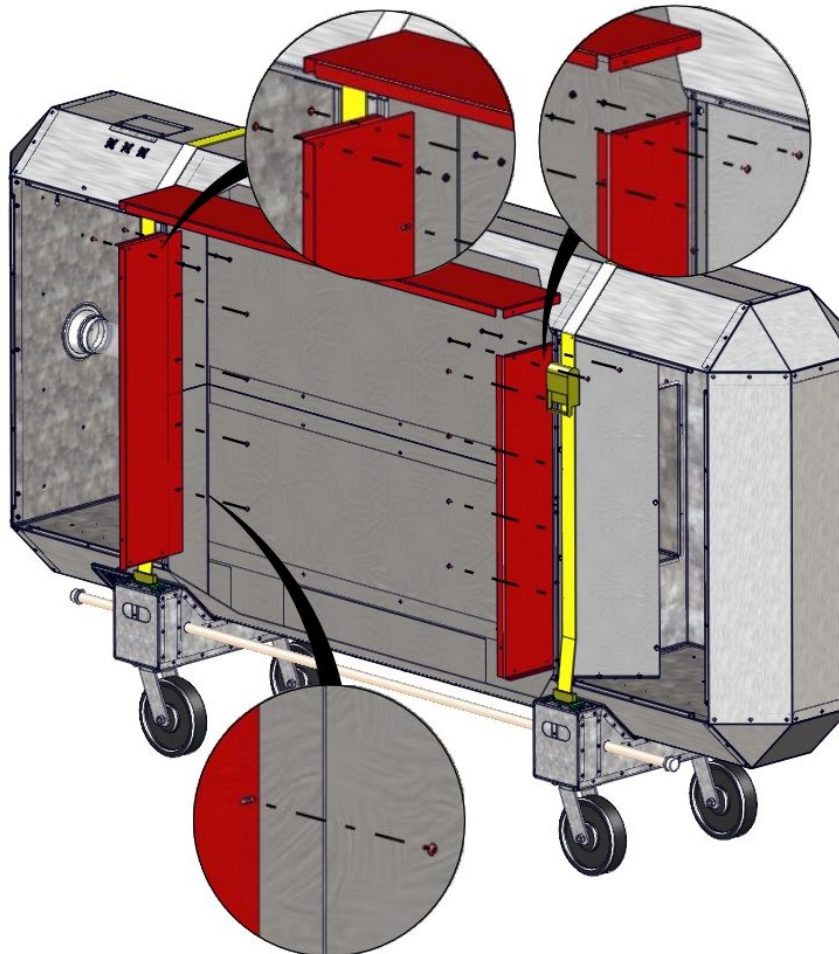

Lifting Gear Setup

XLT hoods can easily be moved and stacked with the proper lifting equipment. The use of XLT approved lifting equipment is highly recommended. Contact XLT for more information.

8

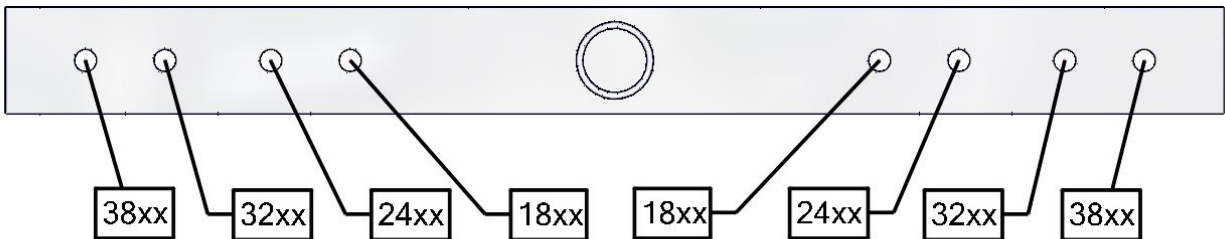
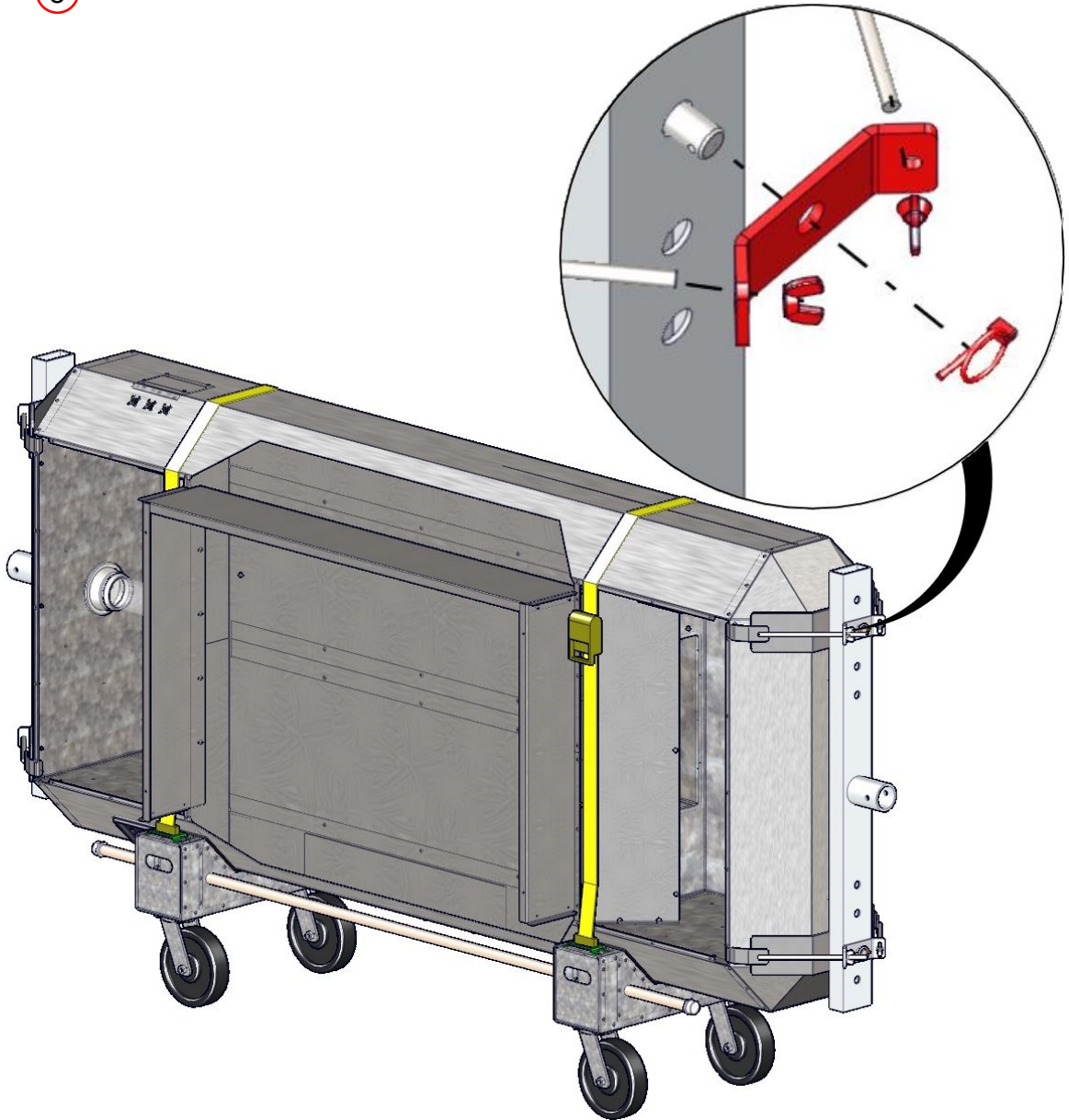

WARNING & SAFETY INFORMATION

An XLT hood can easily be moved with the proper lifting equipment. The use of XLT approved lifting equipment is highly recommended. Contact XLT for more information.

**DANGER**

- These hood is heavy & can tip or fall causing bodily injury
- NEVER place any part of your body beneath any hood that is suspended by the lifting jacks. A crush hazard exists if the hood falls or slips
- DO NOT place your hands on the lifting jack vertical pole beneath the jack's winch. As the jack's winch descends when you turn the jack handle, a pinch point is created between the winch & the pole.

**CAUTION**

BE CAREFUL when rolling the hood on the cart, especially when going up or down ramps & over bumps. Leave the straps/banding on until the oven is near the assembly area.

**DANGER**

- Make sure that the notch on tube of the winch assembly is aligned with the pin in the tripod base as shown (Pg. 89). These alignments are important and keep the jack aligned properly.
- Check for smooth operation. The cable should not be pinched & should pass smoothly over the pulley on top of the pole assembly.
- Inspect cable prior to each use.
- If cable is frayed or shows signs of excessive wear & tear, DO NOT USE until cable is replaced.
- At a minimum replace the cable annually with wire rope that meets or exceeds the jack manufacturer's specifications.
- Do not exceed the stated capacity of the jack.

**DANGER**

Failure to engage the Lifting Jacks into the Lifting Pipe properly and completely will result in damage, injury, or death from a falling hood.

**DANGER**

- Both jacks should be raised in unison, otherwise they may bind and a dangerous situation will develop.
- Do not put any part of yourself under the hood at any time.
- The hood is heavy. Be careful.

Lifting Jack Setup

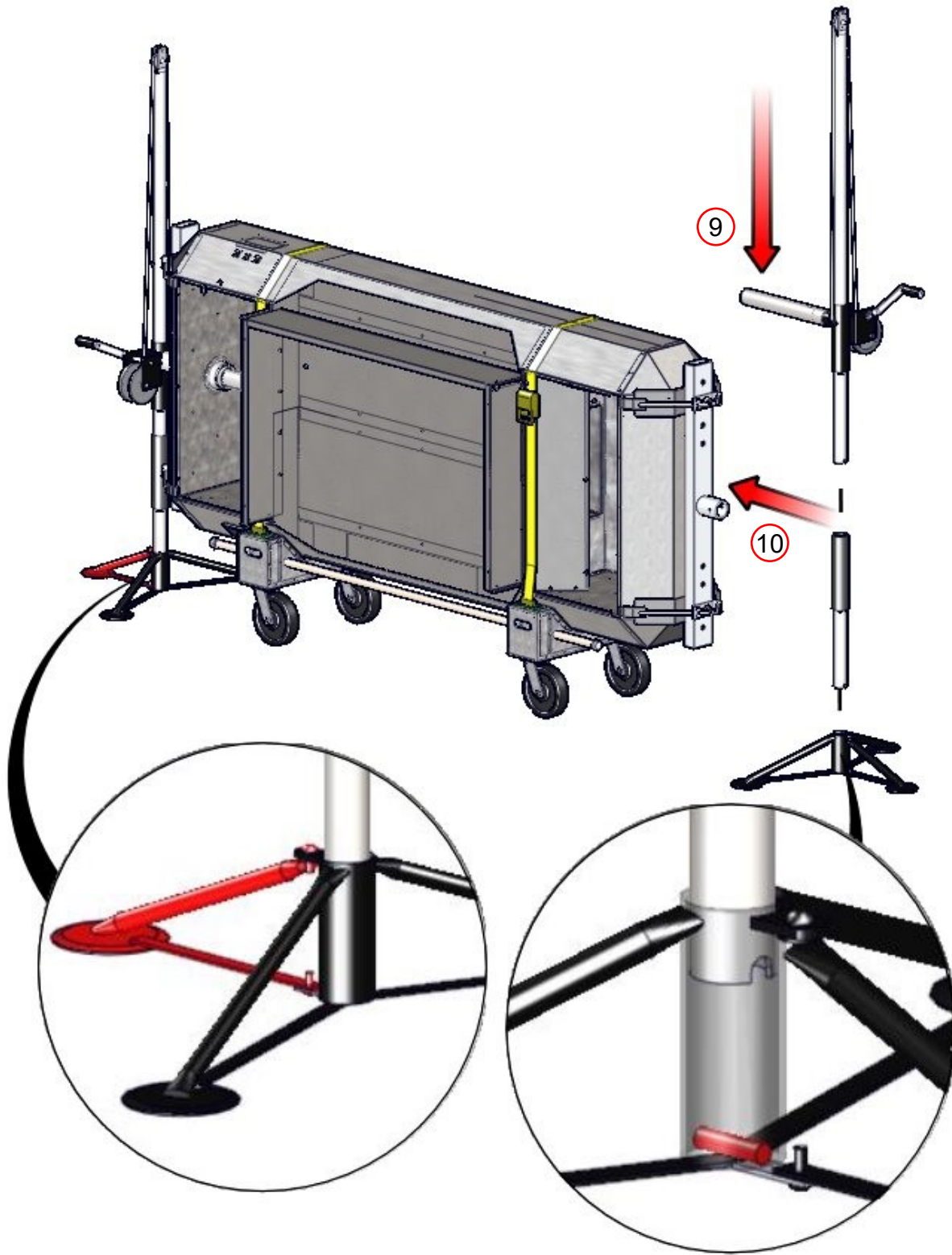

The folding leg of the tripod must be positioned outwards from the hood.

NOTE

Stacking Hood on the Ovens

**DANGER**

- Both jacks should be raised in unison, otherwise they may bind and a dangerous situation will develop.
- Do not put any part of yourself under the hood at any time.
- The hood is top heavy. Be careful.

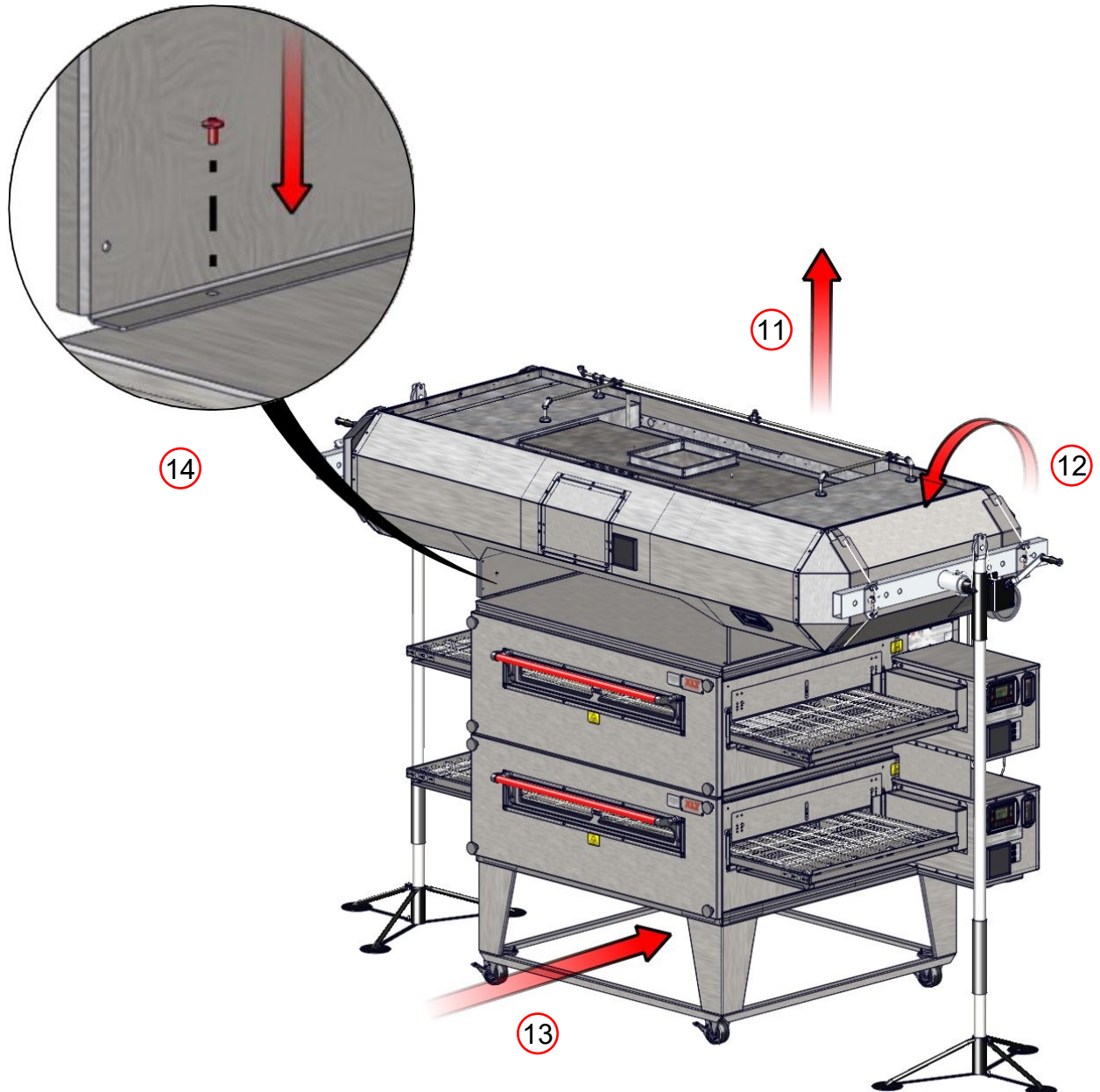

Hang Hood From Ceiling Joists



DANGER

Hood Must Be Suspended From Ceiling Joists

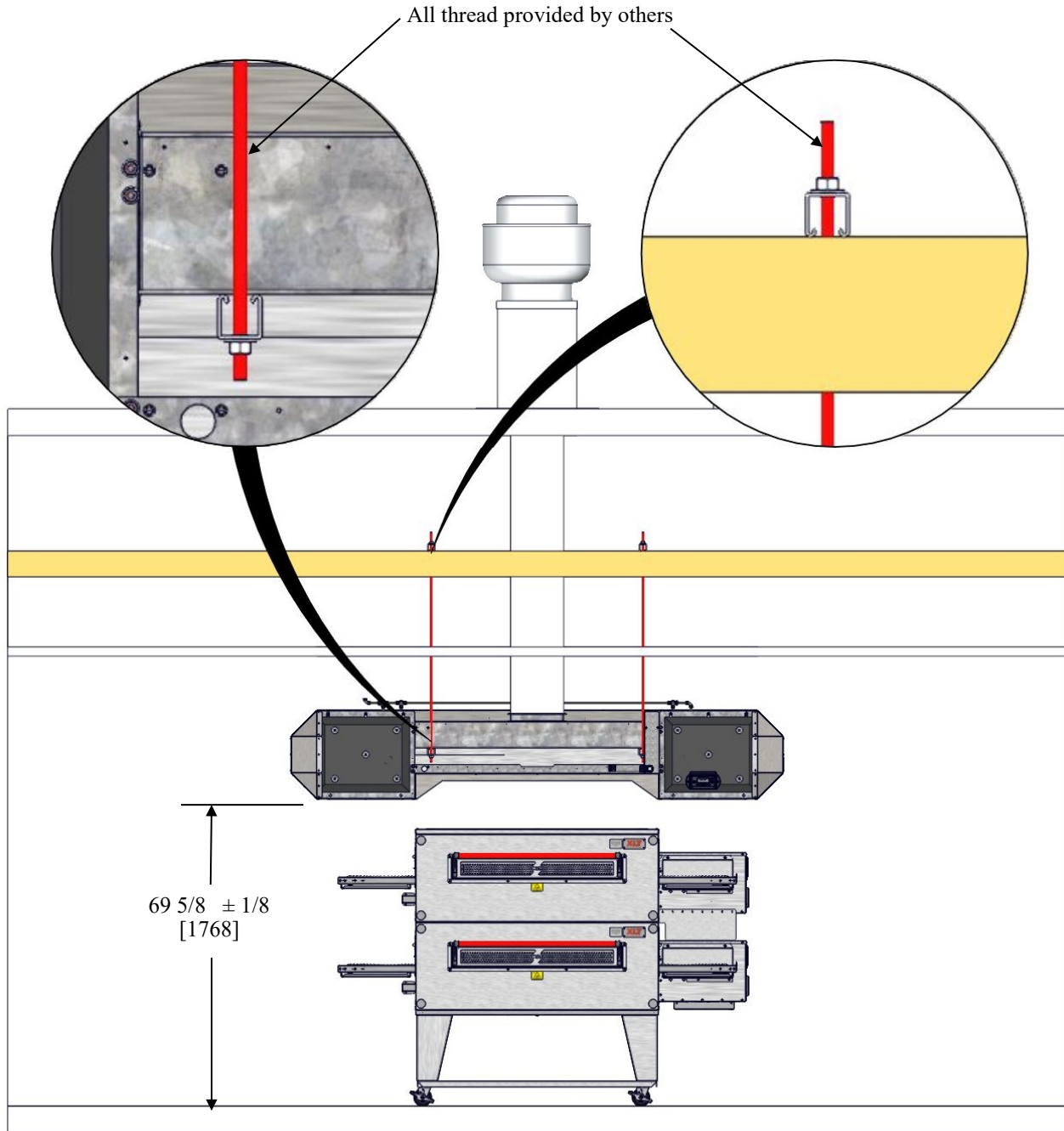

This measurement is from the **finished** floor to the bottom of the suspended hood.

NOTE: All dimensions in inches [millimeters], ± 1/4 [6], unless otherwise noted.

Install Grease Trays, Light Bulbs & Covers, and Grease Filters

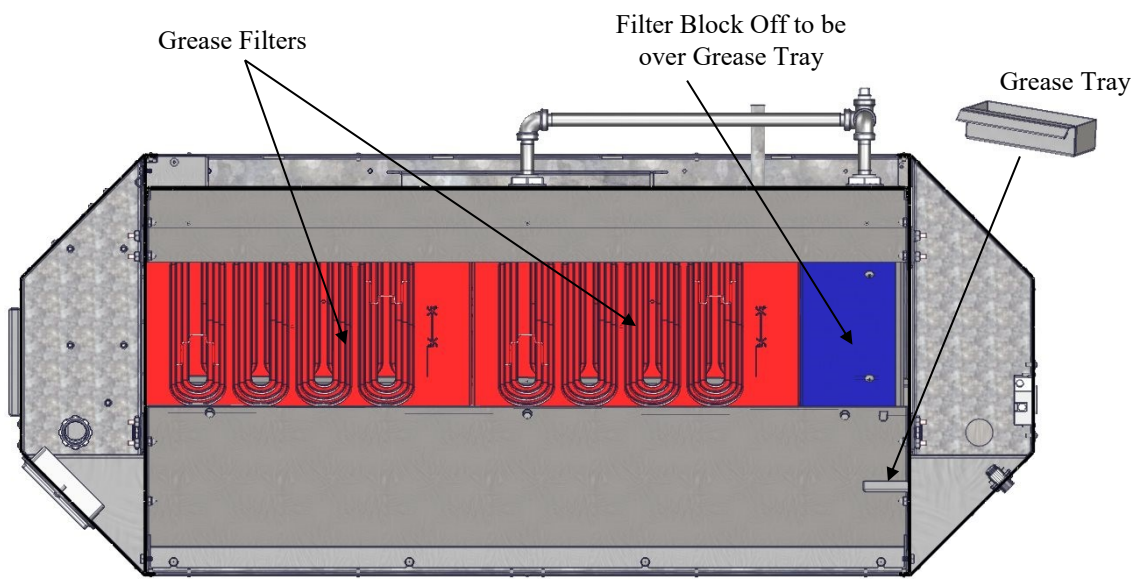
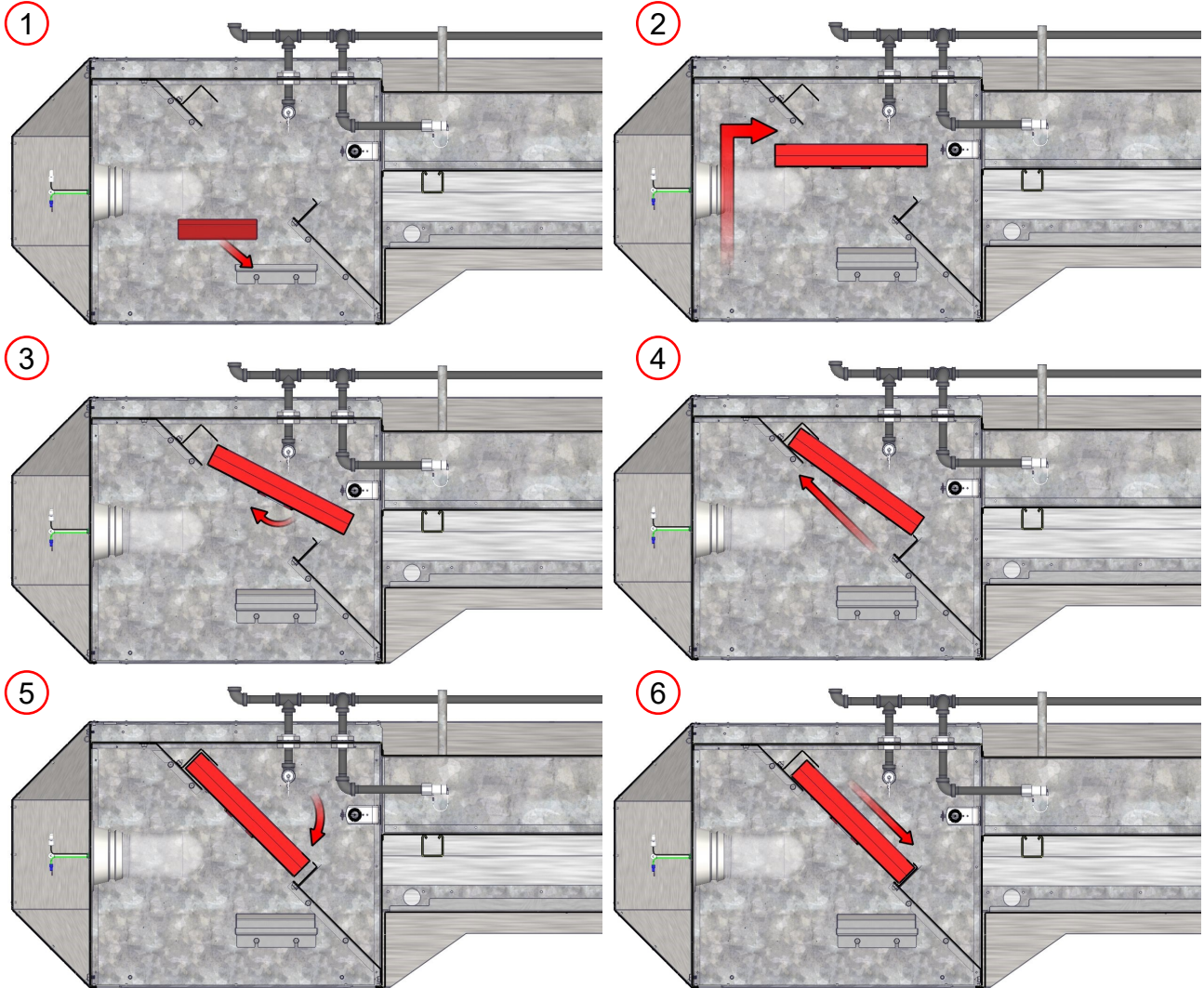



Review and understand the next ten (10) steps first. They illustrate how to install the components of the shrouds.

TIP



CAUTION

Shroud Panels can weigh up to 38 lbs [18 kg]. Use caution when lifting.

Install Shroud Hanging Brackets

1

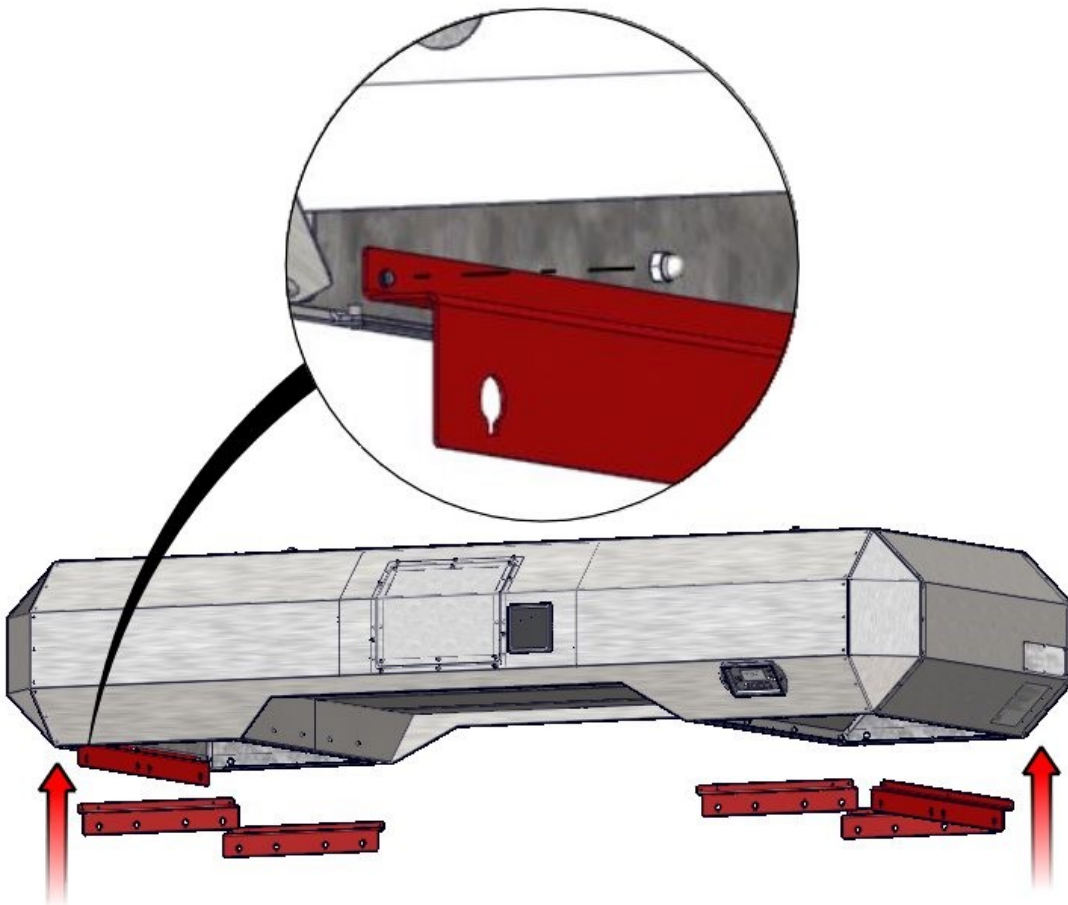

Parts Removed For Clarity

NOTE

Install Corner Posts

2

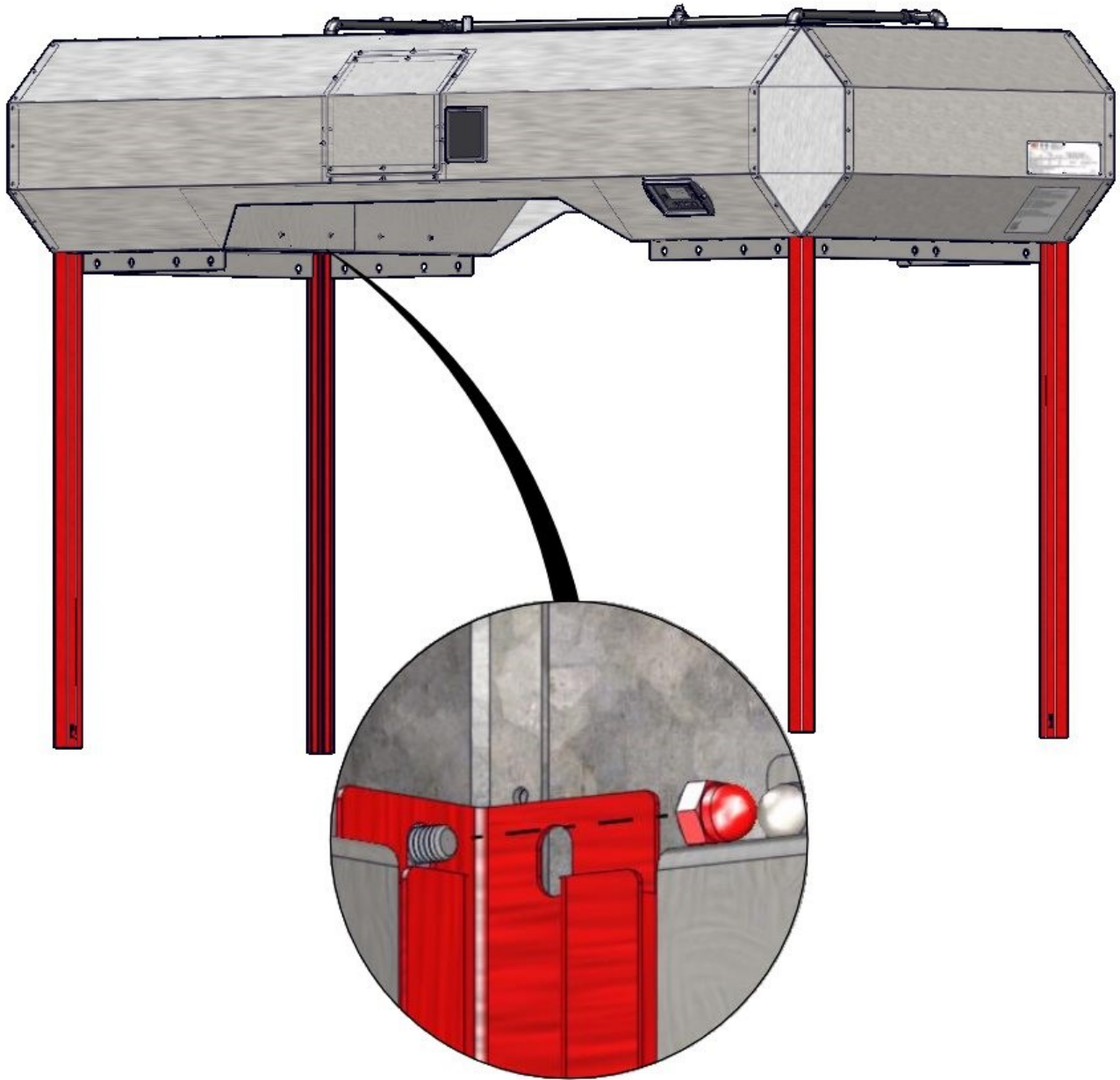

Install Bottom Rails

3a

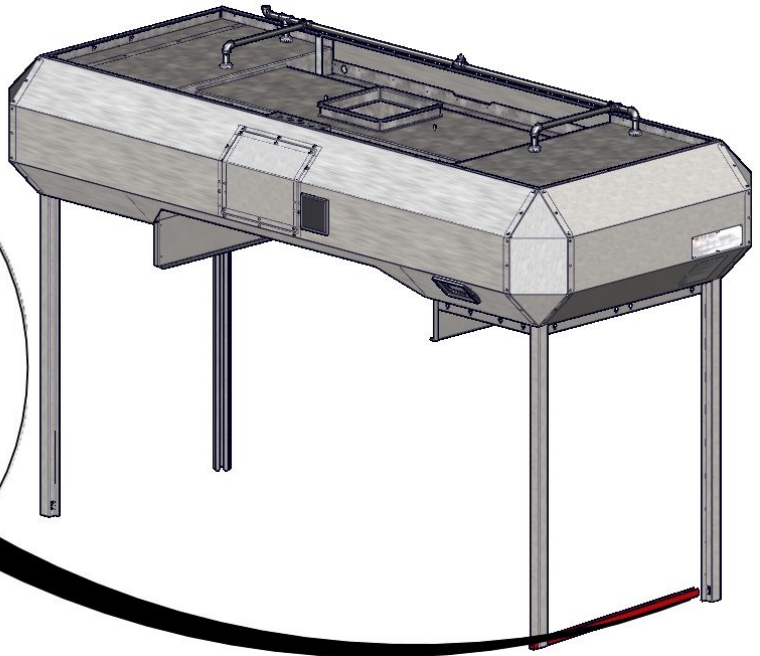
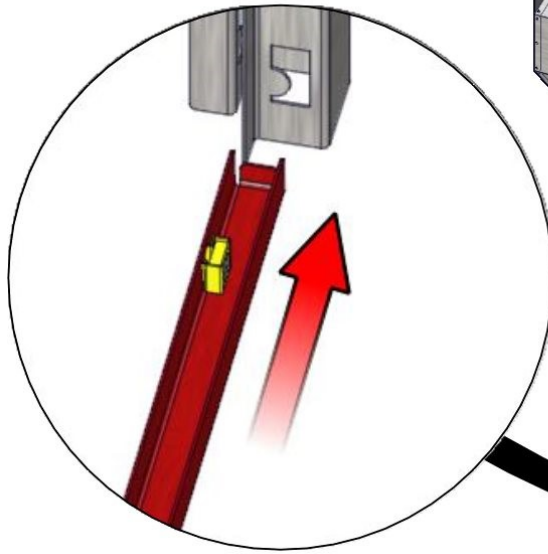

3b

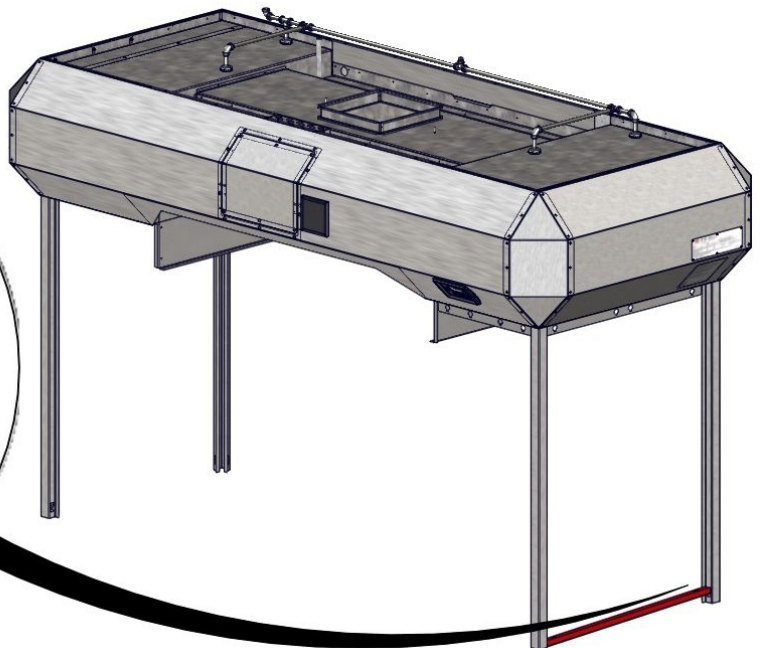
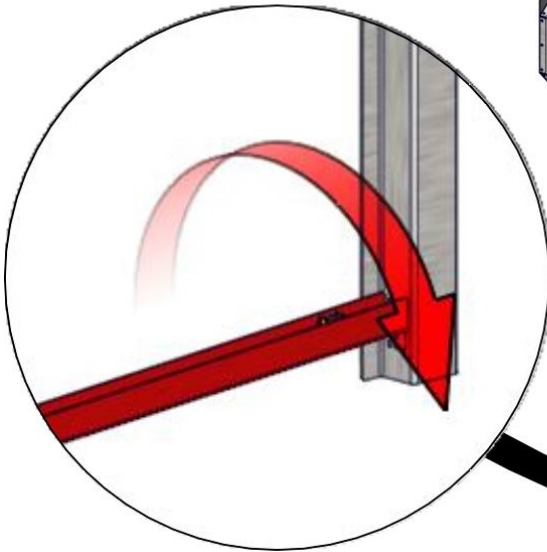

Install Bottom Rails

3c

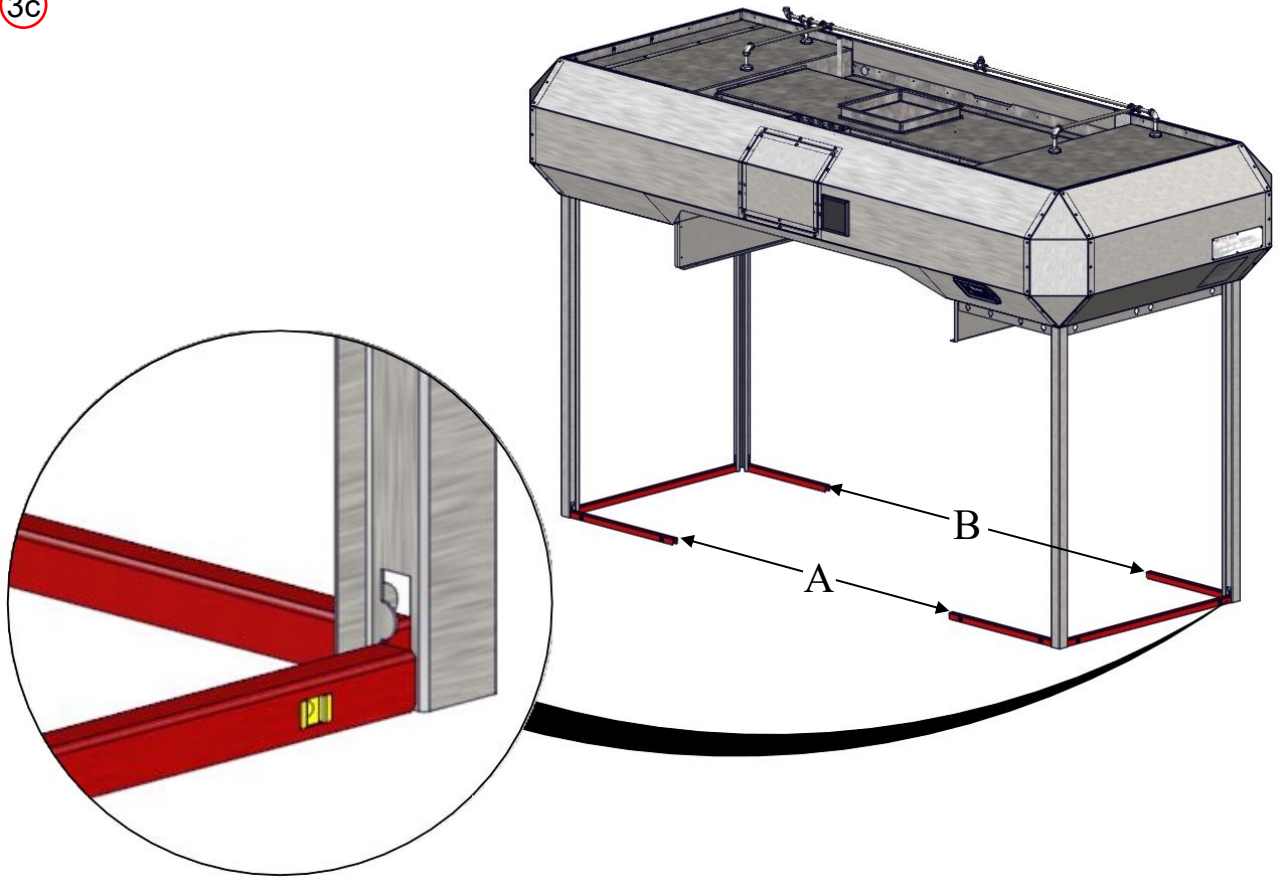

Oven Model	Bottom Rail Widths	
	A	B
1832	32 [813]	41 [1041]
2440	40 [1016]	49 [1245]
3240	40 [1016]	49 [1245]
3255	55 [1397]	64 [1626]
3270	70 [1778]	79 [2007]
3855	55 [1397]	64 [1626]
3870	70 [1778]	79 [2007]

NOTE: All dimensions in inches [millimeters], $\pm 1/4$ [6], unless otherwise noted.

Install Control Box Upper Closeout

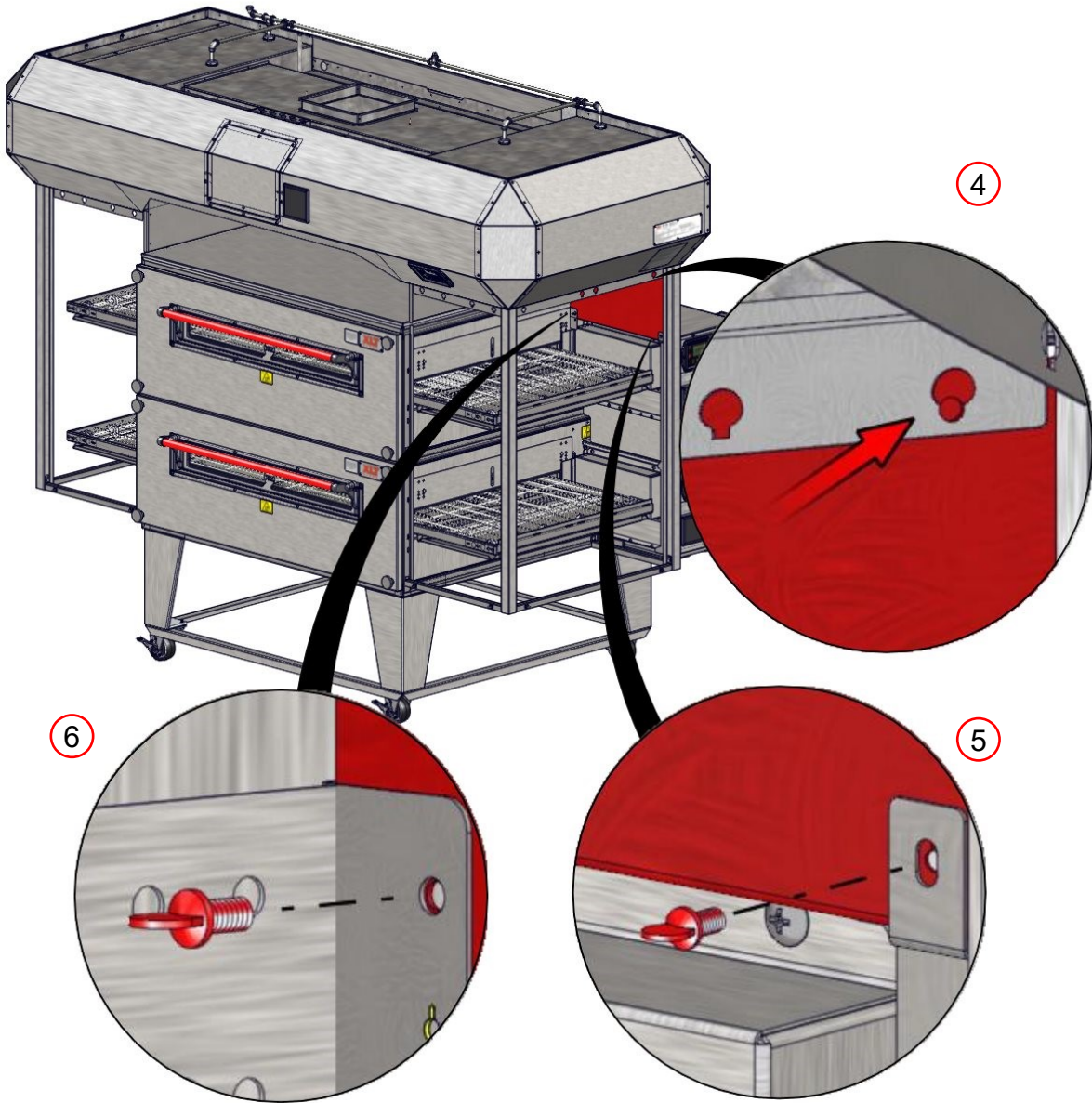

Install Shroud Panels - Front and Ends

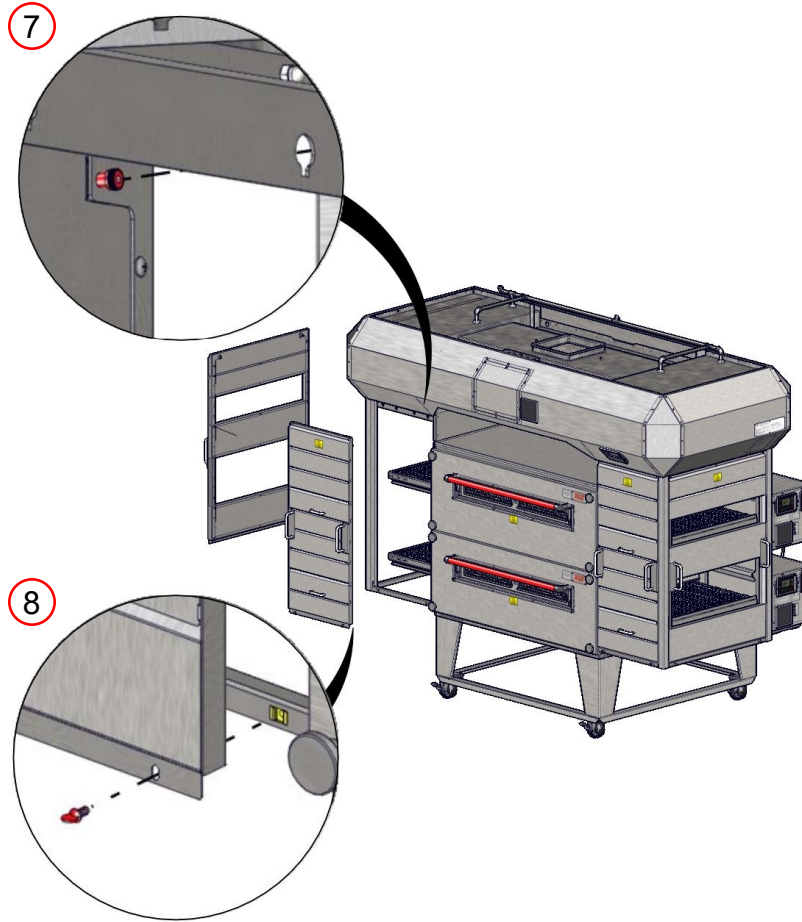

Install Conveyor Shelf

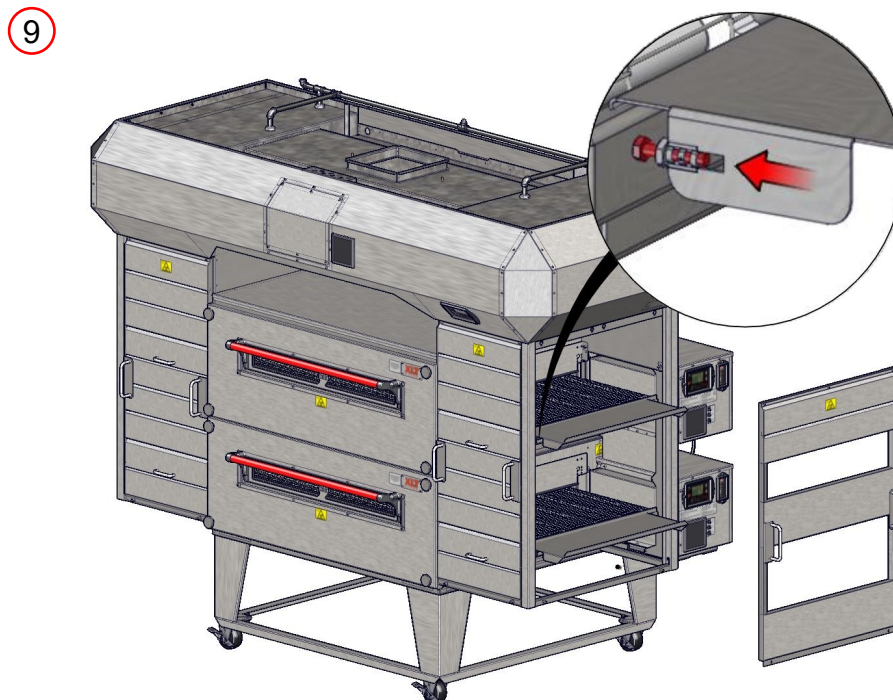

Install Back Shroud Panel

⑩

Skip this step if the oven(s) are two burner models.

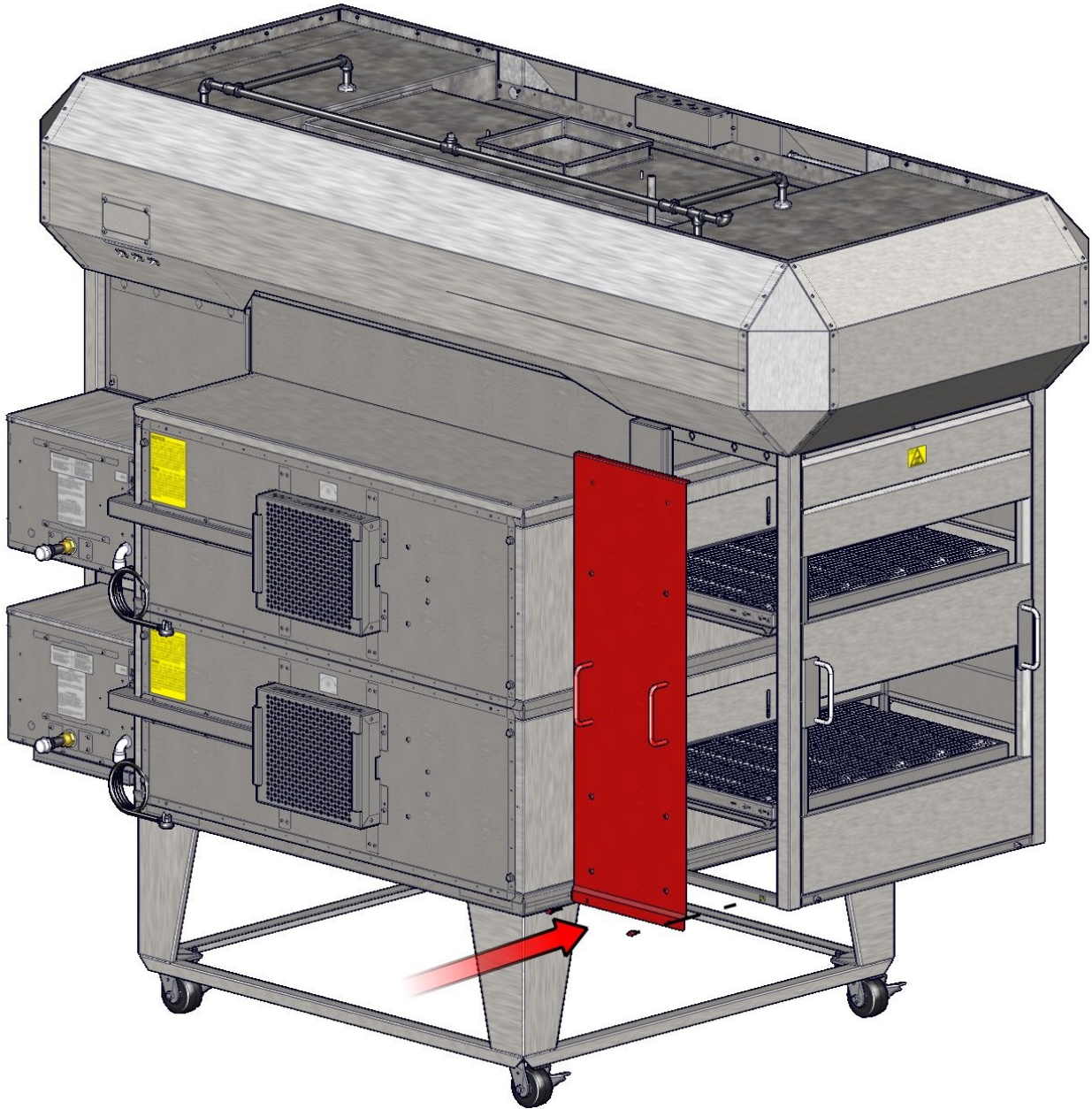

Install Hood Relocation Cord Assembly

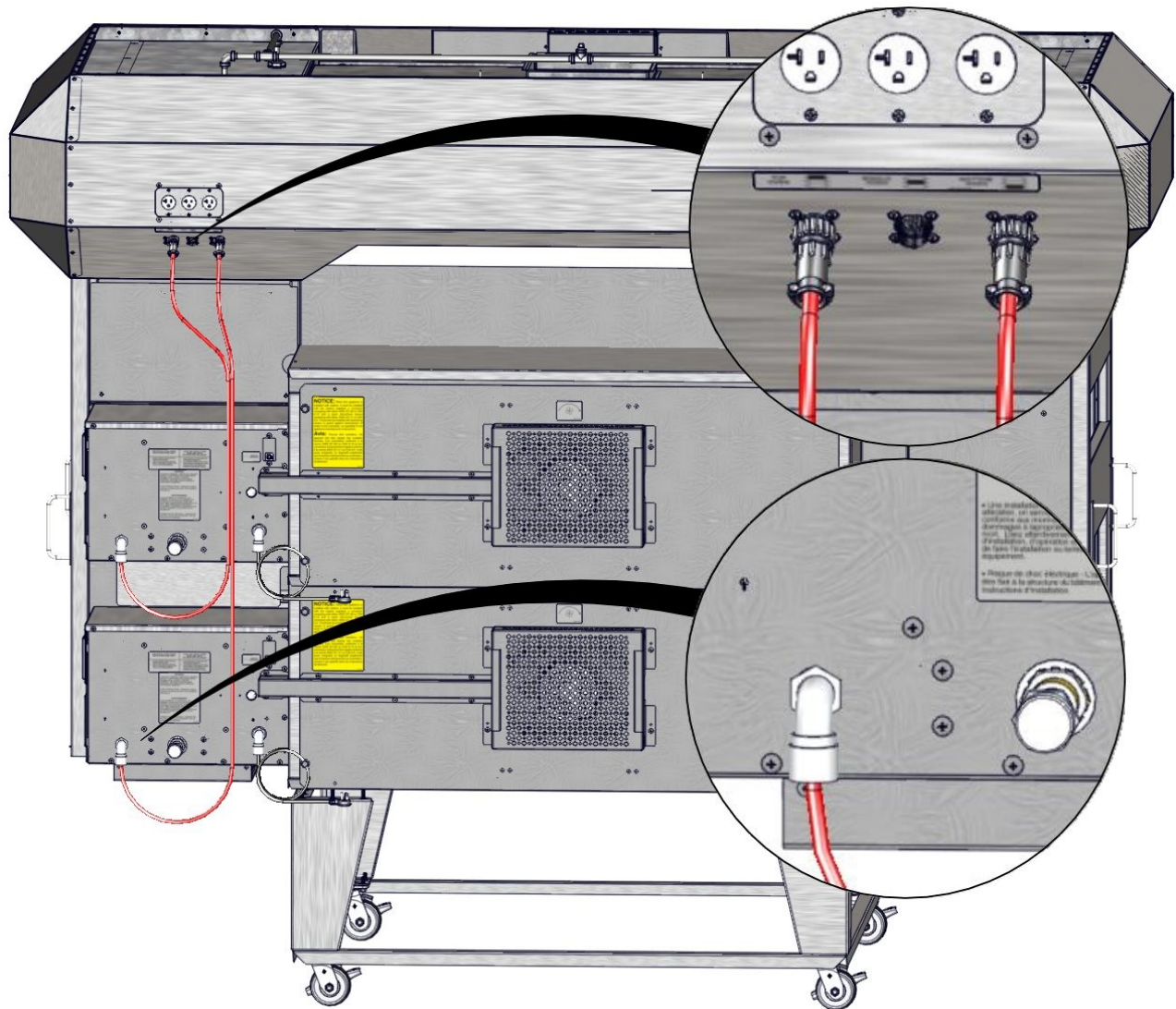

All hoods are outfitted with three (3) switch relocation receptacles, regardless of how many XLT ovens are installed. For a single oven use “Top” location. For a double stack use “Top” location for upper oven and “Bottom” location for lower oven, leaving “Middle” location open.

Insert and lock each oven control cord into the designated location on the bottom of the hood control box.

Connect Hood Relocation Cord Assembly

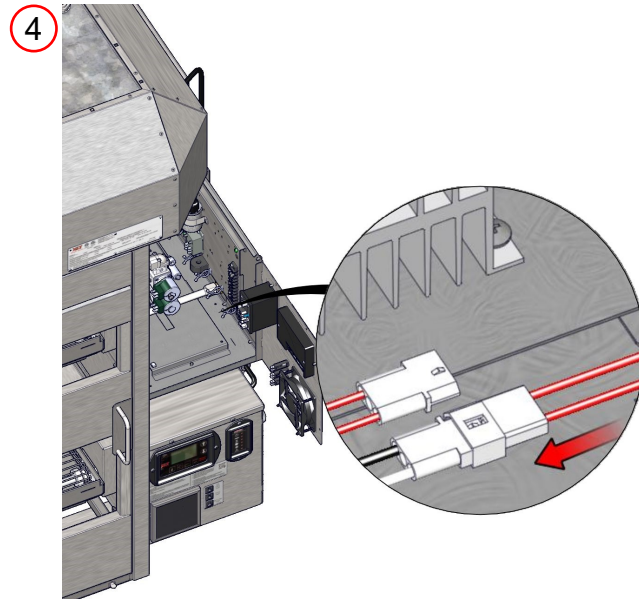
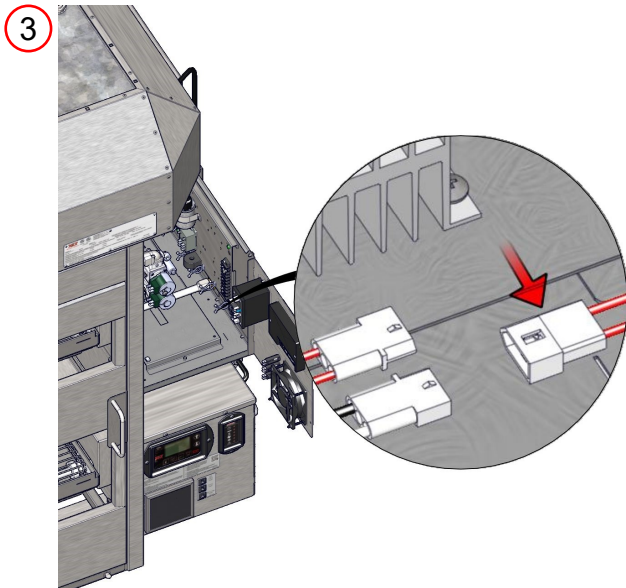
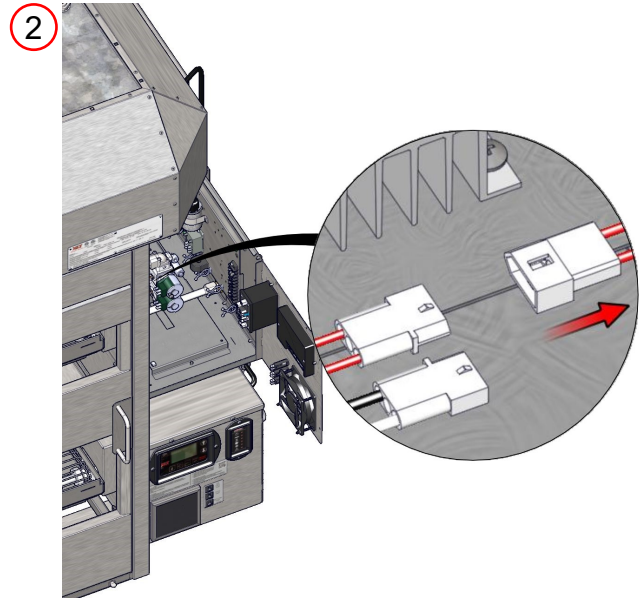
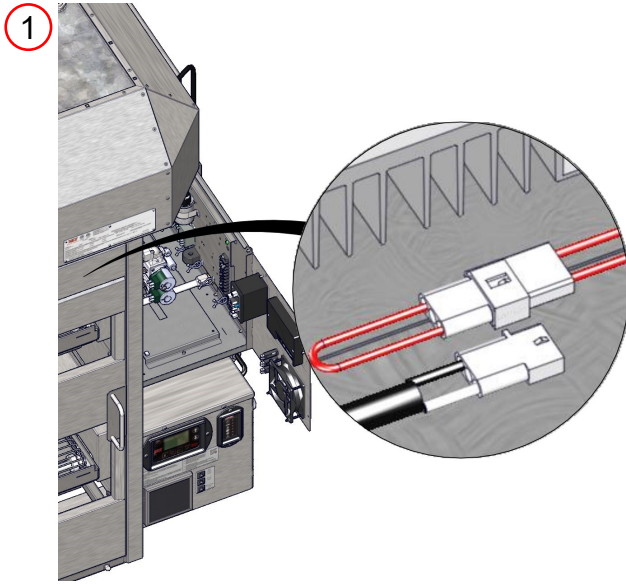

Variable Frequency Drive Adjustments

All XLT Hoods are functionally tested at the factory. Operation is verified, and adjustments are made to ensure proper operation. However, field conditions are sometimes different than factory conditions. **It is necessary to have an authorized service technician verify operation and make field adjustments if needed.**

The following items must be checked and verified to meet the specifications and requirements stated in this manual prior to the hood being commissioned:

- Correct fan rotation
- Balanced make-up air

The Hood Initial Start-Up Checklist, found at the end of this manual, must be completed at time of installation, signed by the Customer and returned to XLT and the Authorized Distributor to initiate Warranty Policy. **If the Start-Up Checklist is not filled out completely and returned to XLT, the Warranty will not be honored.**

The VFD controller is adjusted at the factory to the values displayed in the chart below.

	VFD Controller Settings					
	Ovens On			1832 & 2440	3240, 3255 & 3270	3855 & 3870
	Top	Middle	Bottom			
Single	X			20 Hz	25 Hz	30 Hz
Double	X			20 Hz	25 Hz	30 Hz
			X	35 Hz	40 Hz	45 Hz
	X		X	35 Hz	40 Hz	45 Hz
Triple	X			20 Hz	25 Hz	30 Hz
		X		30 Hz	35 Hz	40 Hz
			X	40 Hz	45 Hz	50 Hz
	X	X		30 Hz	35 Hz	40 Hz
	X		X	40 Hz	45 Hz	50 Hz
		X	X	40 Hz	45 Hz	50 Hz
	X	X	X	45 Hz	50 Hz	55 Hz
Fire Suppression			60 Hz DO NOT CHANGE			

If you require either more or less air flow, follow these steps: (Reference Hood User Interface image on next page)

1. Press & hold the LIGHTS and XLT LOGO buttons to enter into factory tech mode.
2. Use the Up/Down arrows to reach manual air balance.
3. Press and hold ENTER button for three (3) seconds. Entire row will flash.
4. Scroll to desired oven setting. Press ENTER.
5. +/- should flash and it allows +/- change up to 10 Hz.
6. Press ENTER to save changes.
7. Press ON to test air balance.

Initial Start Up

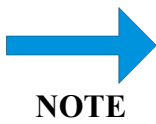
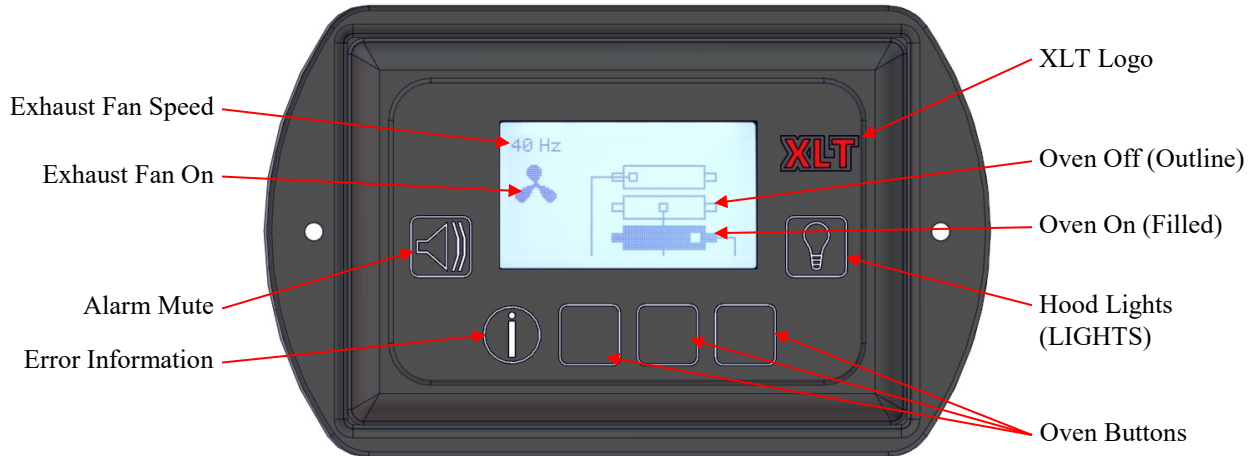

When XLT ovens are outfitted with an XLT hood and the receptacles are plugged into the hood instead of the wall, the main power button of the oven is disabled and no longer operates. The Hood User Interface (HUI) on the XLT hood overrides the oven power button.

Hood Operation

1. Turn the desired oven(s) on by pressing the corresponding oven button. Refer to the Oven Operation section for instructions on how to adjust temperature and conveyor speed. The oven(s), exhaust fan, and make-up air unit will be activated by this switch if the XLT hood is installed according to this manual.
2. Turn on the lights by pressing the hood lights button on the HUI. (Bulbs not included with hood)
3. When additional ovens are turned on, via the HUI the VFD will automatically increase the exhaust fan speed.
4. When shutting down the ovens, turn the desired oven off by pressing the corresponding button on the HUI. The make-up air unit will shut off. The exhaust fan will shut off after about fifteen (15) minutes and the oven will shut off after about thirty (30) minutes.

Resetting Hood Cooling Fan and Grease Timer

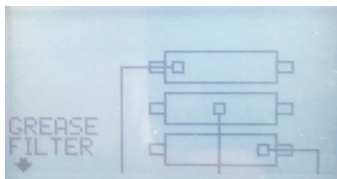

1. The Cooling Fan and Grease Filter reset alarm will show up in the lower left hand side of the Hood User Interface. Press the Error Information button to enter reset screen.



2. To reset the Cooling Fan or Grease Filter press the center capacitive touch button with reset above it to set the time back to zero (0).



3. The following screen will show for five (5) seconds and then return to the normal operating screen.

The optional valance kit size is determined by XLT hood size & distance from the finished floor to the installed drop ceiling height. The valance kit screws directly to the XLT hood and does not require any structural support. The plastic coating must be removed from all parts prior to installation.

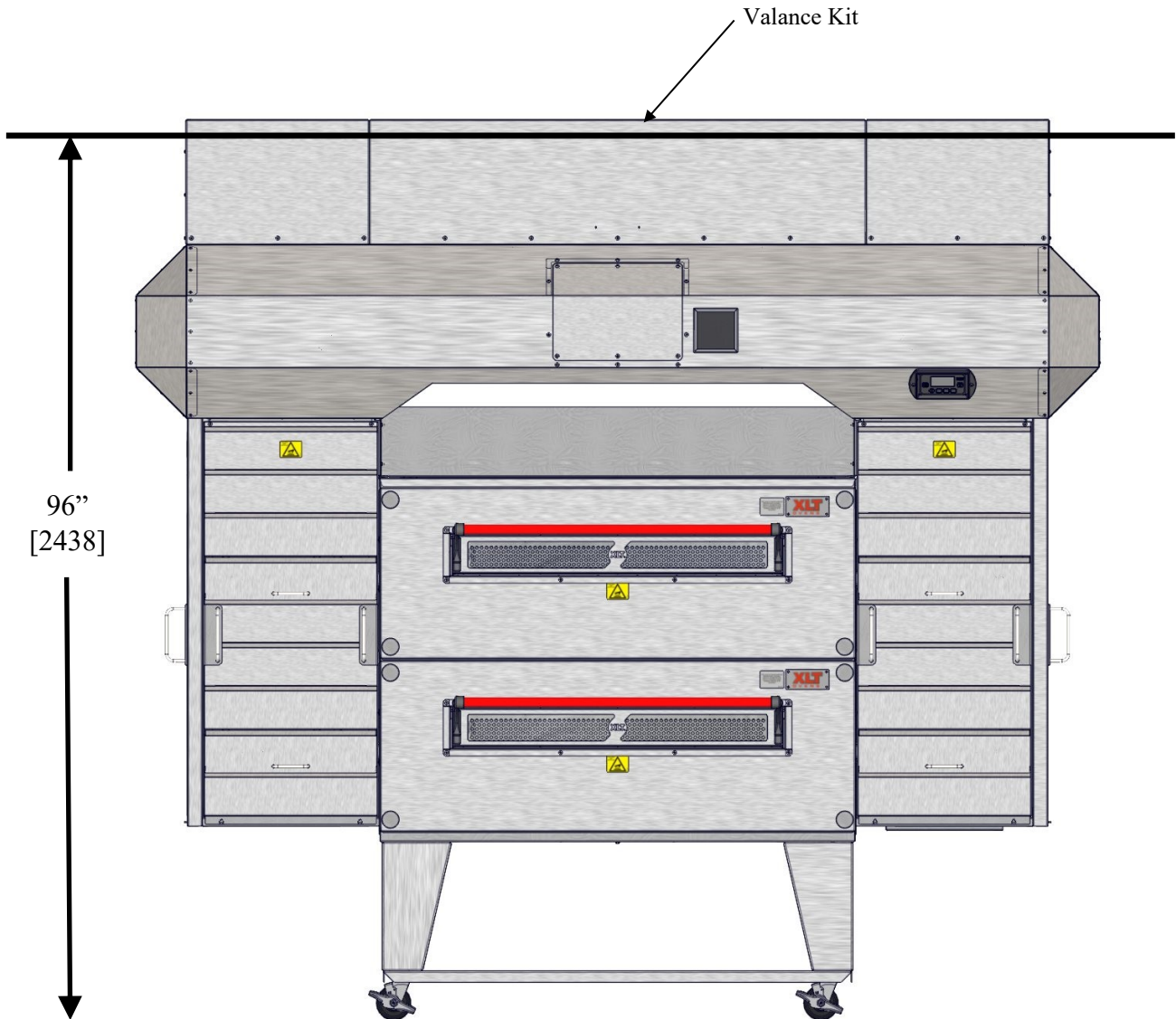

This measurement is from the **finished** floor to the bottom of the suspended hood.

XLT hood valance kits are available for different floor to ceiling heights. Contact XLT or your designated representative for more information.

NOTE: All dimensions in inches [millimeters], $\pm 1/4$ [6], unless otherwise noted.

Install Valance Brackets

①

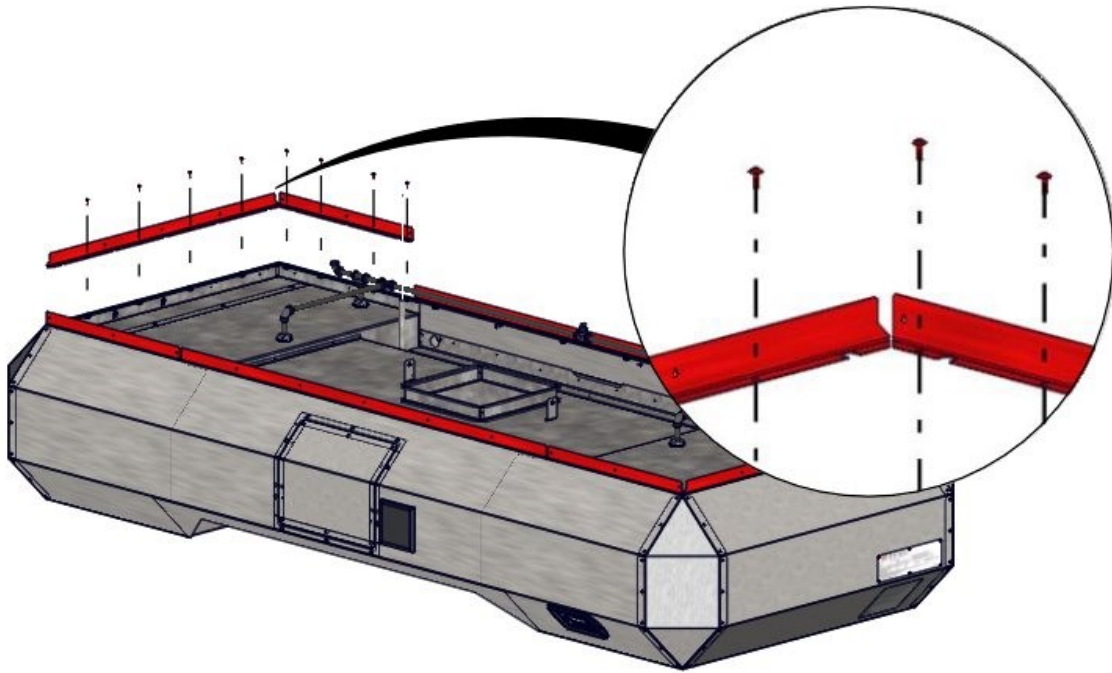

Install Front & Back Panels

②

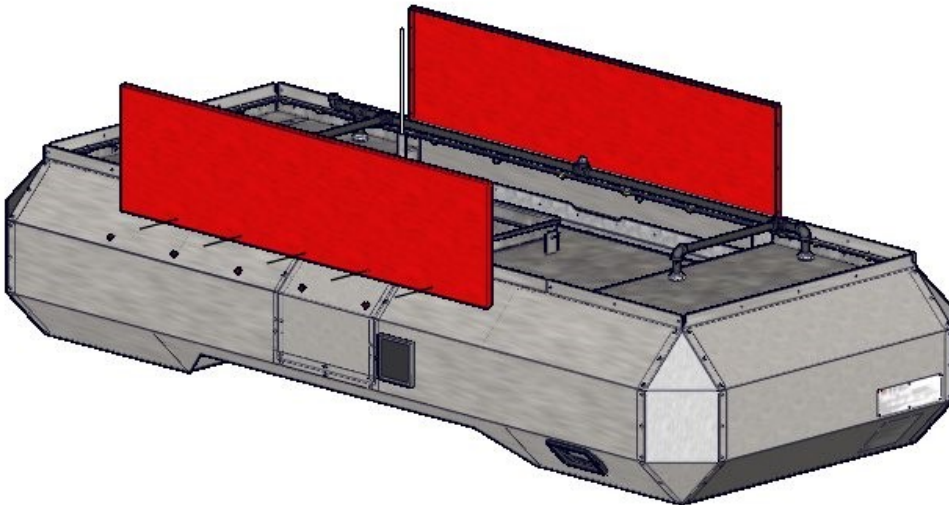

Install Corner Panels

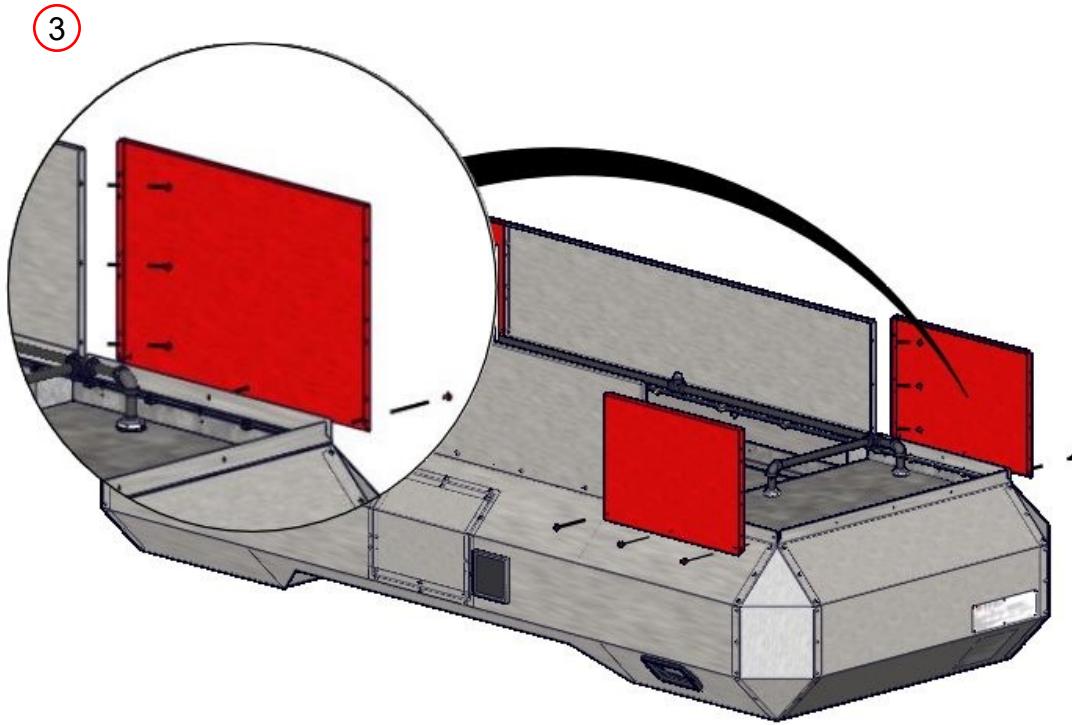

Install End Panels

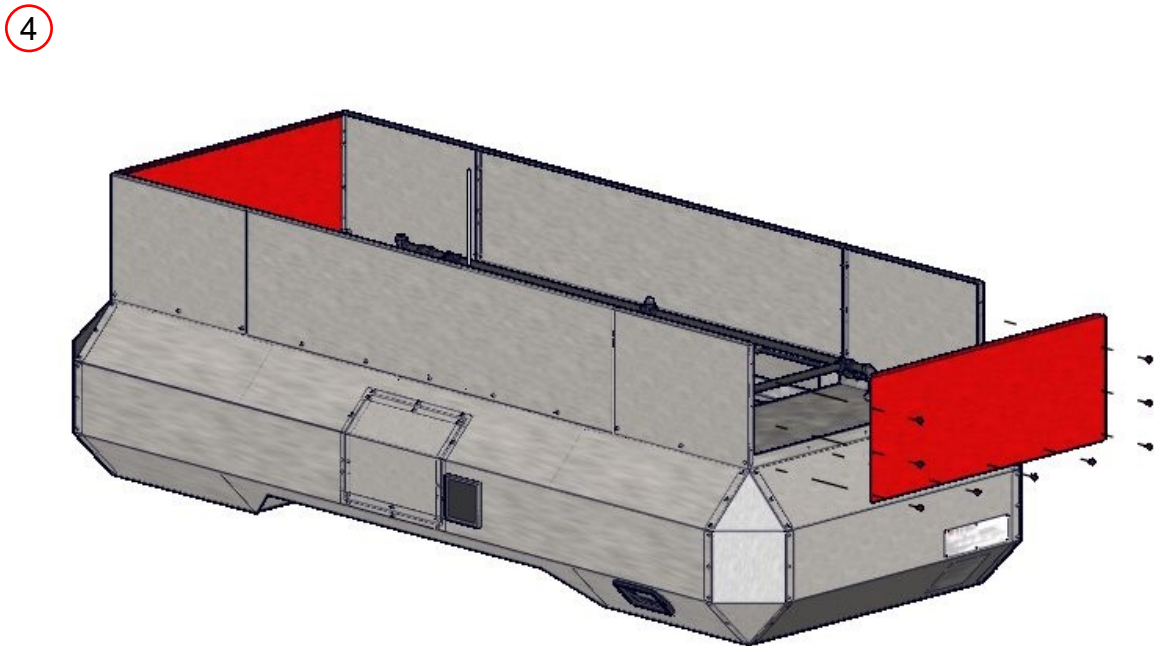

Optional Hood Duct Wrap Install Duct Wrap Brackets

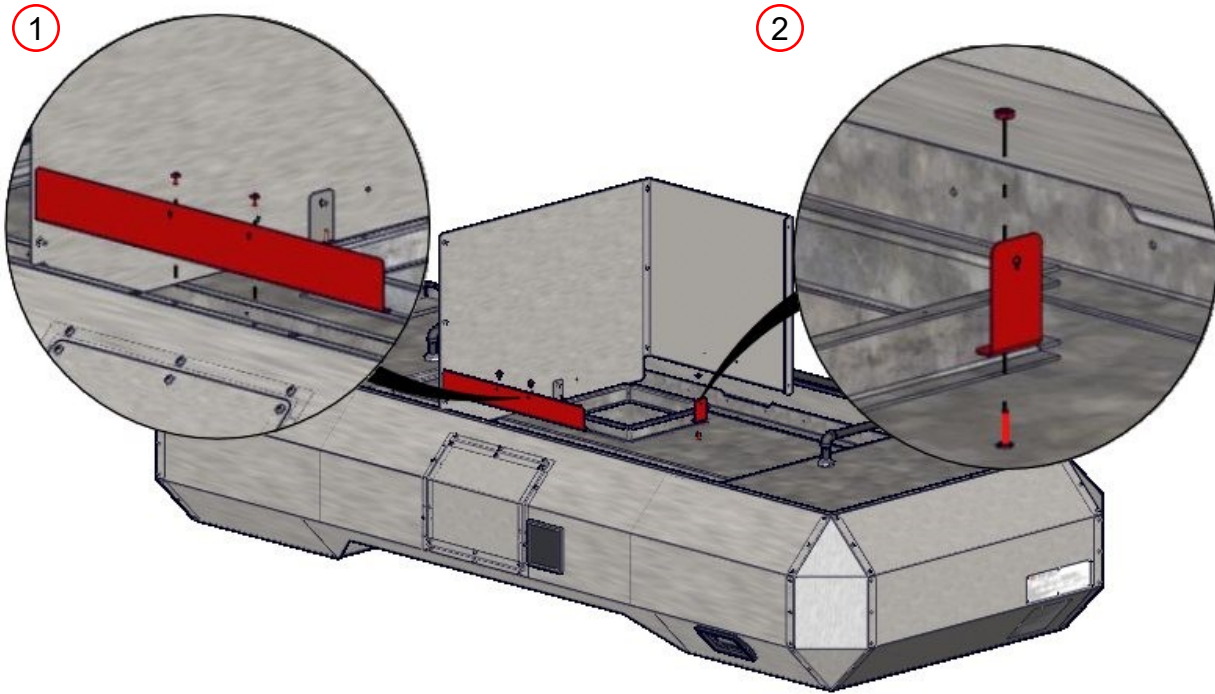

Install Duct Wrap Panels

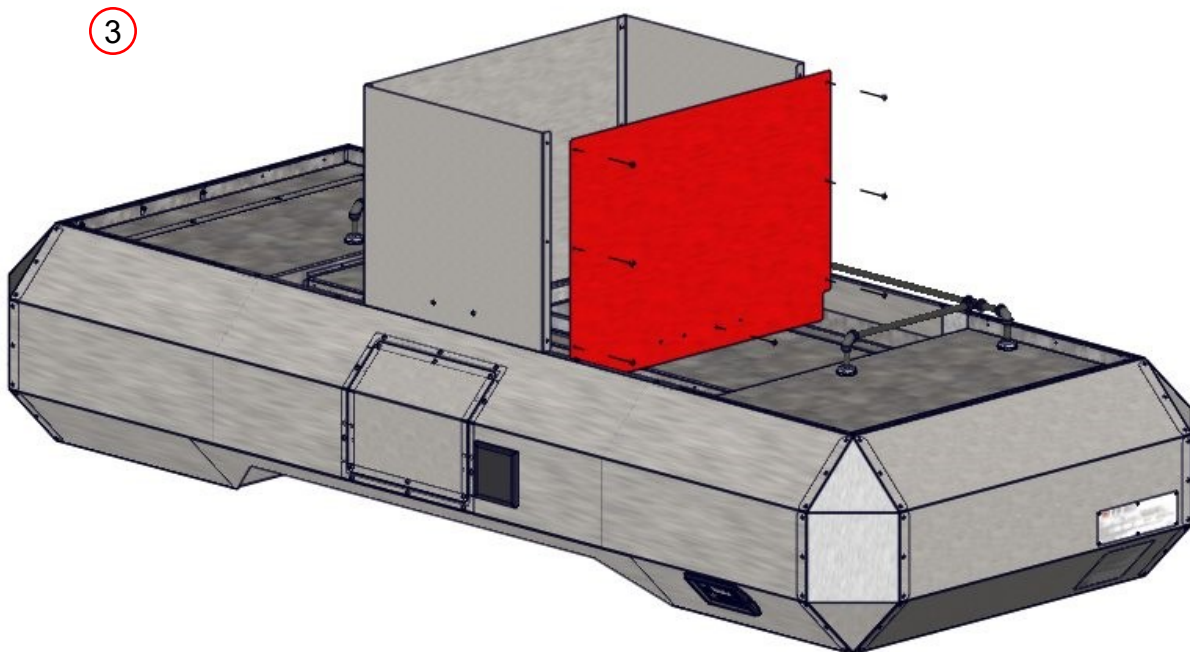

As with any appliance, periodic maintenance is required. Many factors affect this schedule such as product mix and hours of usage. An example schedule is included.

Your XLT hood is constructed of stainless and aluminized steel. Check application restrictions on product label prior to usage. Observe recommended precautionary and safety measures as dictated by the product manufacturer. Bleach can cause stainless steel to discolor and corrode and is not recommended for cleaning.

Do not use abrasive or caustic cleaners. Abrasive pads will scratch stainless steel surfaces. Areas with heavy buildup should be sprayed and allowed to soak for up to five (5) minutes prior to wiping clean. Always wipe with the “grain” of the surface to maintain appearance.

**DANGER**

Oven must be cool and the electric cord unplugged before any cleaning is done.

**CAUTION**

Shroud Panels can weigh up to 38 lbs [18 kg]. Use caution when lifting.

**CAUTION**

DO NOT spray liquid cleaning agents in the hood electrical box (located on front of upper portion), or the Large User Interface (Located on front lower right corner).

Hood Cleaning & Maintenance Schedule

	Daily	Weekly	Monthly	Semi-Annual	As Required
Cleaning					
Wipe down Front, Sides, & Top	<input type="checkbox"/>				
Clean Light Globes	<input type="checkbox"/>				
Empty & Clean Grease Trays	<input type="checkbox"/>				<input type="checkbox"/>
Clean Fan Filter	<input type="checkbox"/>				
Clean Grease Filters		<input type="checkbox"/>			<input type="checkbox"/>
Clean Duct and Exhaust Fan			<input type="checkbox"/>		<input type="checkbox"/>
Replace					
Fan Filter					<input type="checkbox"/>
Light Bulbs					<input type="checkbox"/>

This page is intentionally left blank.

112 OVEN SCHEMATIC - STANDARD 1 BOX 120 VAC LH

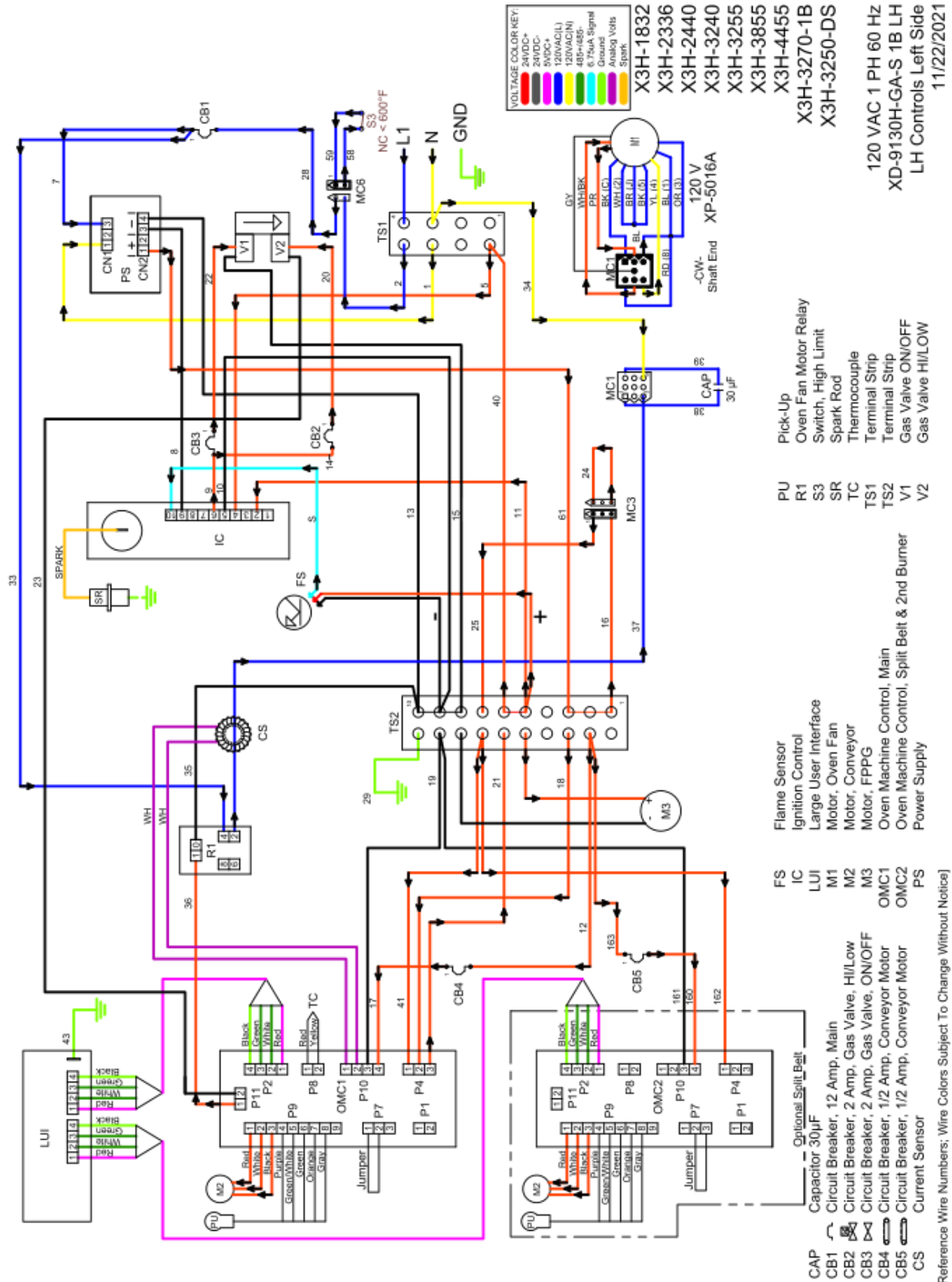

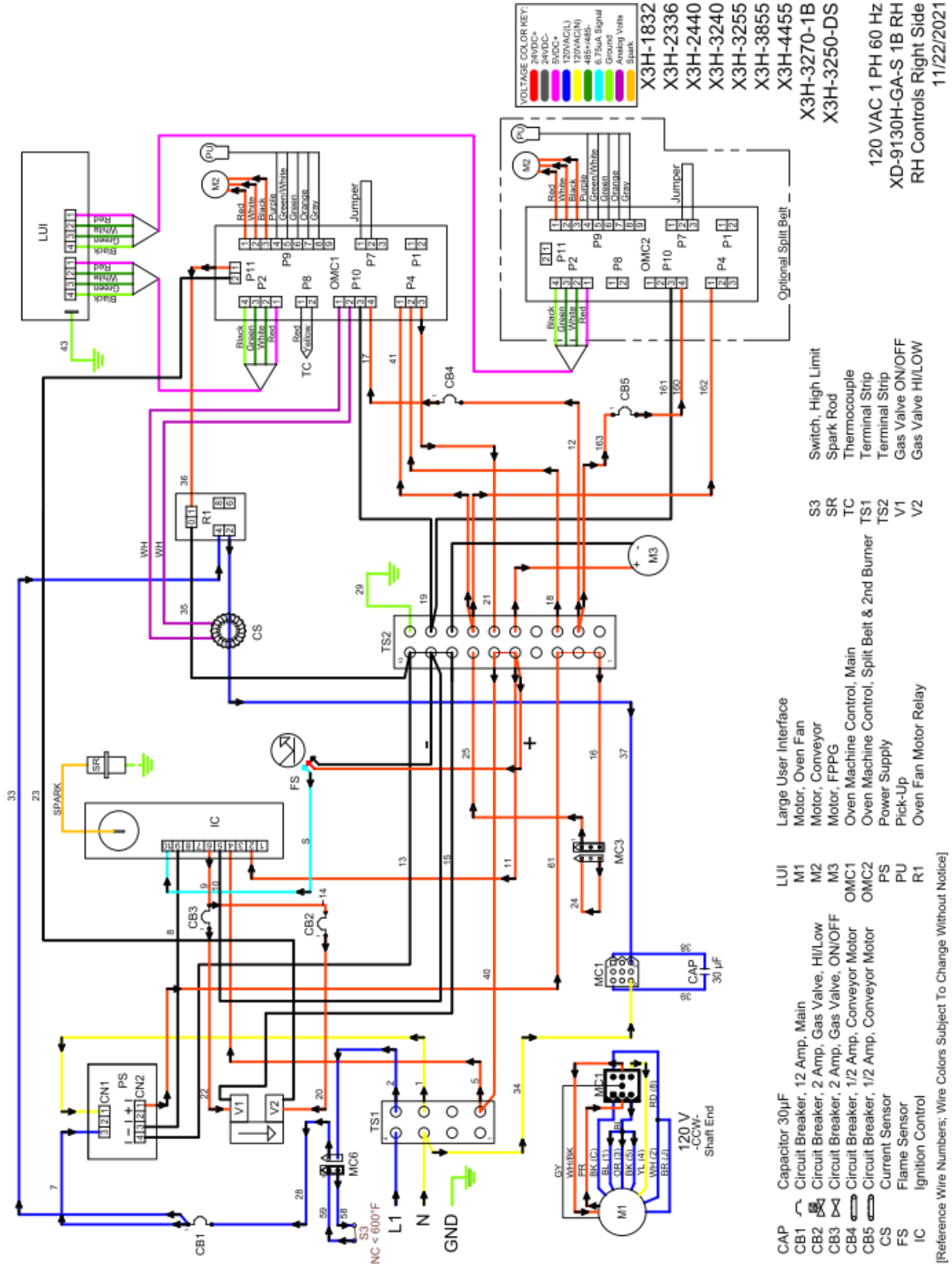

This page is intentionally left blank.

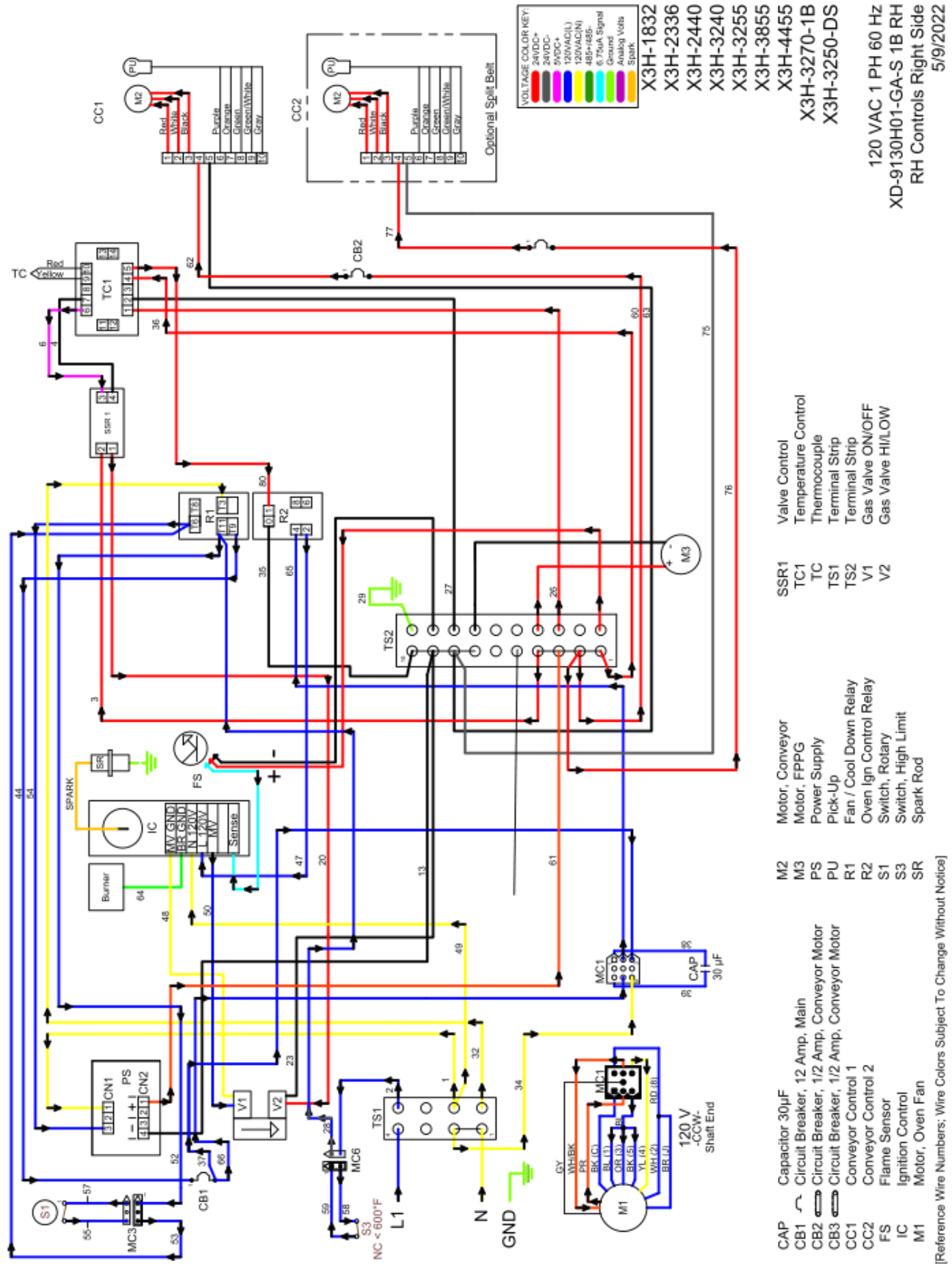

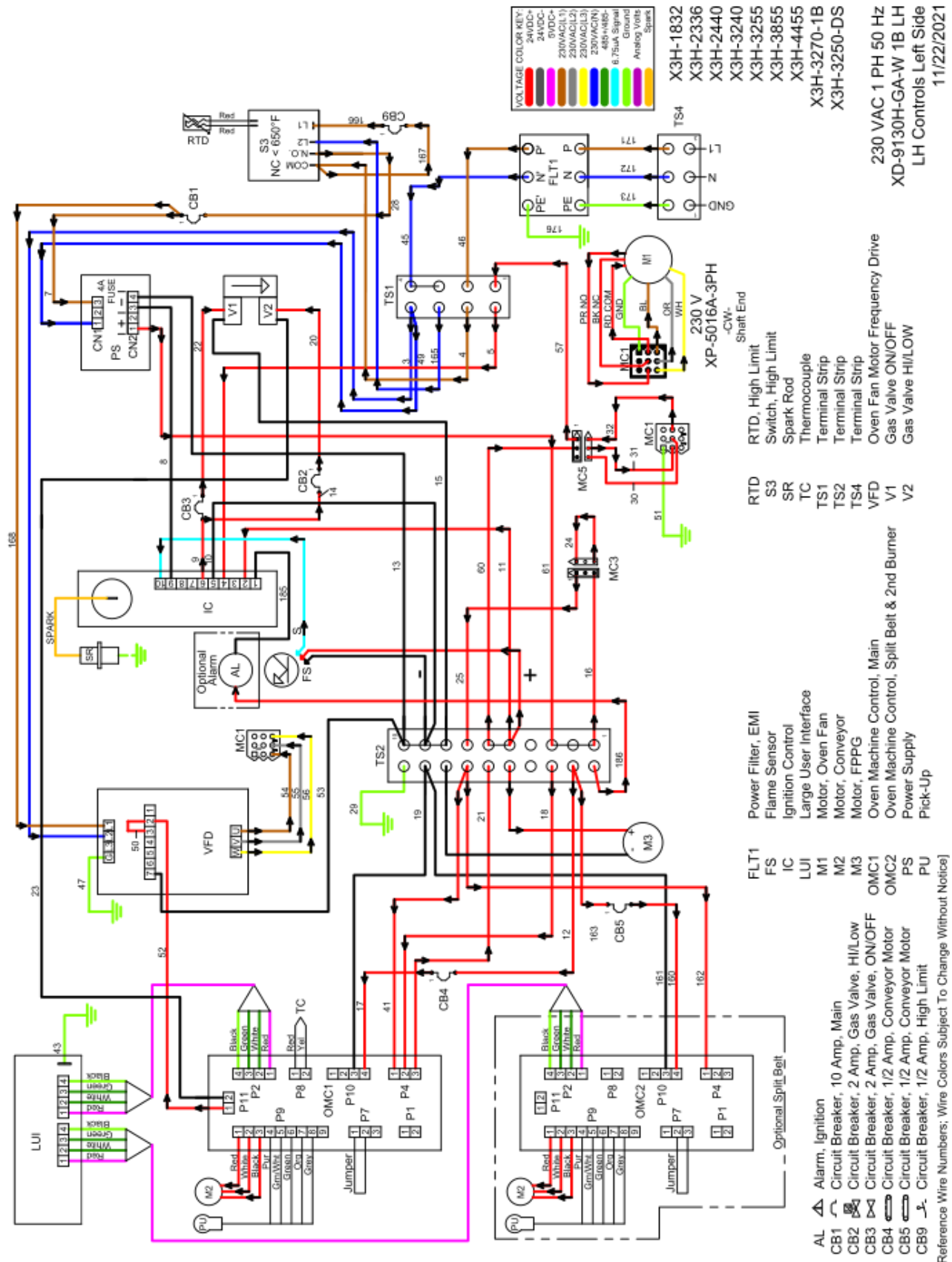

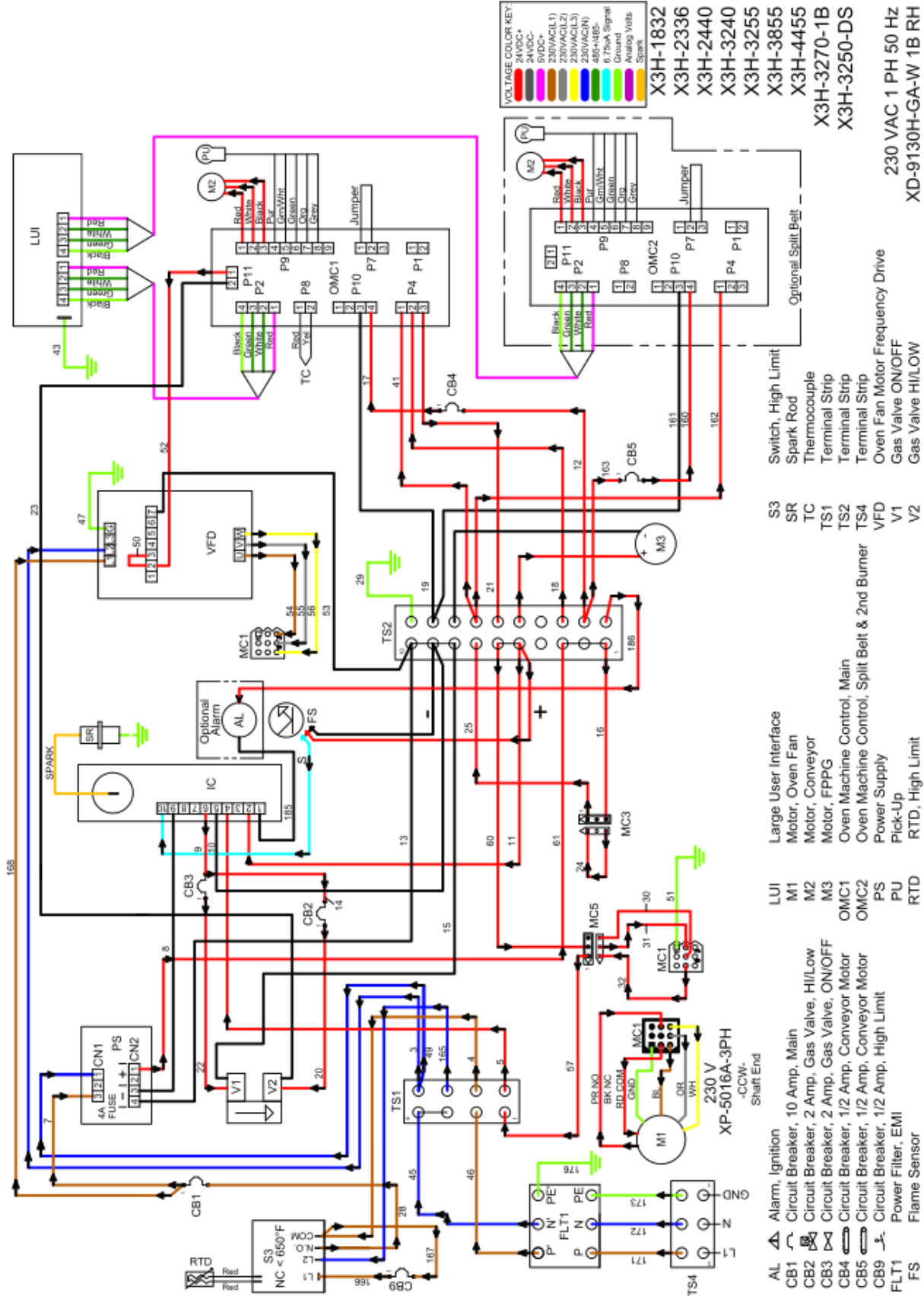

VOLTAGE COLOR KEY:

Red	24VDC+
Black	0VDC+
White	200V(AC/L1)
Green	200V(AC/L2)
Blue	200V(AC/L3)
Yellow	230V(AC/N)
Orange	485-485C-
Purple	6.75A Signal
Light Blue	Ground
Light Green	Analog Vols
Light Yellow	Spark

- X3H-1832
- X3H-2336
- X3H-2440
- X3H-3240
- X3H-3255
- X3H-3855
- X3H-4455
- X3H-3270-1B
- X3H-3250-DS

230 VAC 1 PH 50 HZ
 XD-9130H-GA-W 1B RH
 RH Controls Right Side
 11/22/2021

- S3 Switch, High Limit
- SR Spark Rod
- TC Thermocouple
- TS1 Terminal Strip
- TS2 Terminal Strip
- TS4 Terminal Strip
- VFD Oven Fan Motor Frequency Drive
- V1 Gas Valve ON/OFF
- V2 Gas Valve HI/LOW

- LUI Large User Interface
- M1 Motor, Oven Fan
- M2 Motor, Conveyor
- M3 Motor, FPPG
- OMC1 Oven Machine Control, Main
- OMC2 Oven Machine Control, Split Belt & 2nd Burner
- PS Power Supply
- PU Pick-Up
- RTD RTD, High Limit

- AL Alarm, Ignition
- CB1 Circuit Breaker, 10 Amp, Main
- CB2 Circuit Breaker, 2 Amp, Gas Valve, HI/Low
- CB3 Circuit Breaker, 2 Amp, Gas Valve, ON/OFF
- CB4 Circuit Breaker, 1/2 Amp, Conveyor Motor
- CB5 Circuit Breaker, 1/2 Amp, Conveyor Motor
- CB9 Circuit Breaker, 1/2 Amp, High Limit
- FLT1 Power Filter, EMI
- FS Flame Sensor
- IC Ignition Control

[Reference Wire Numbers; Wire Colors Subject To Change Without Notice]



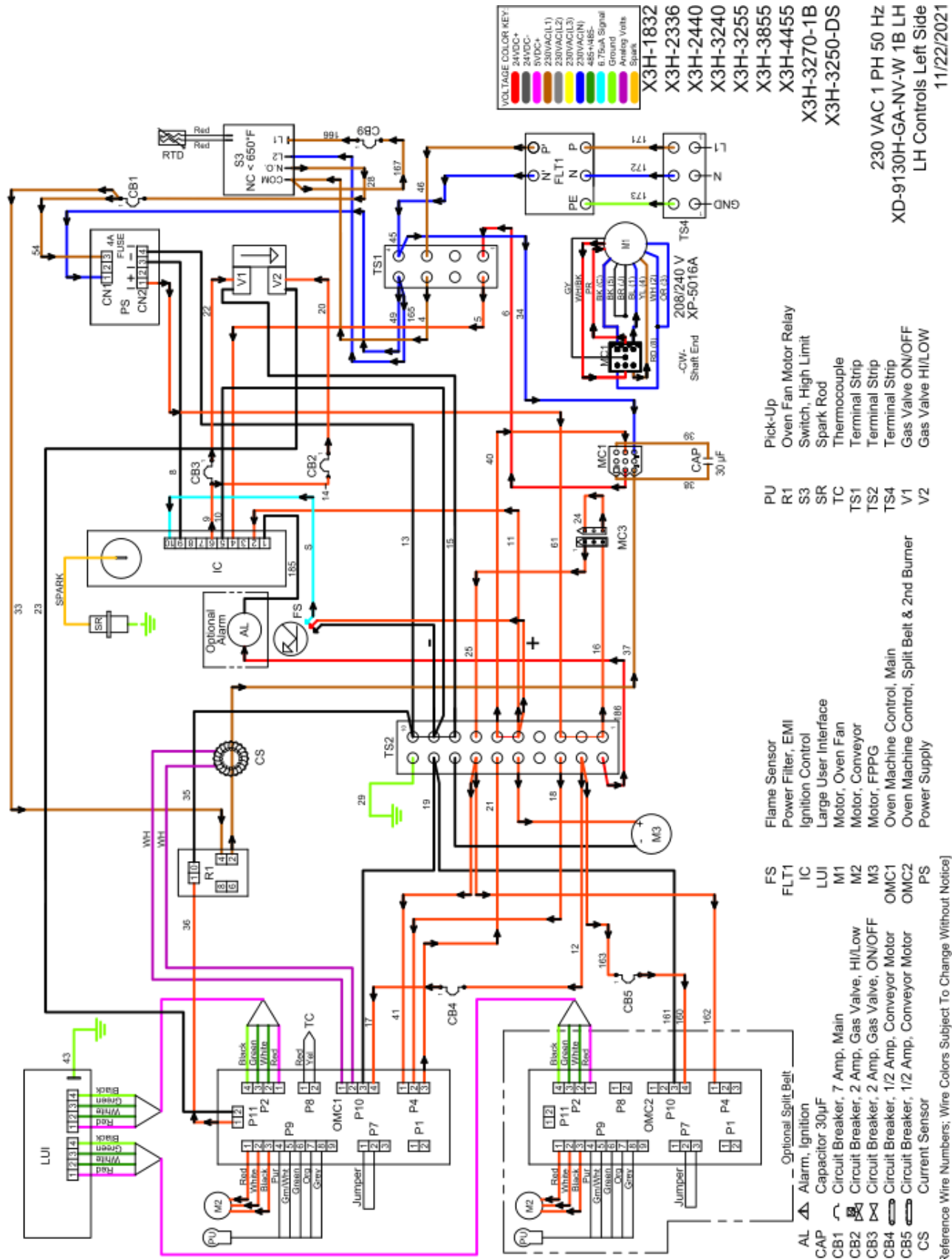

This page is intentionally left blank.

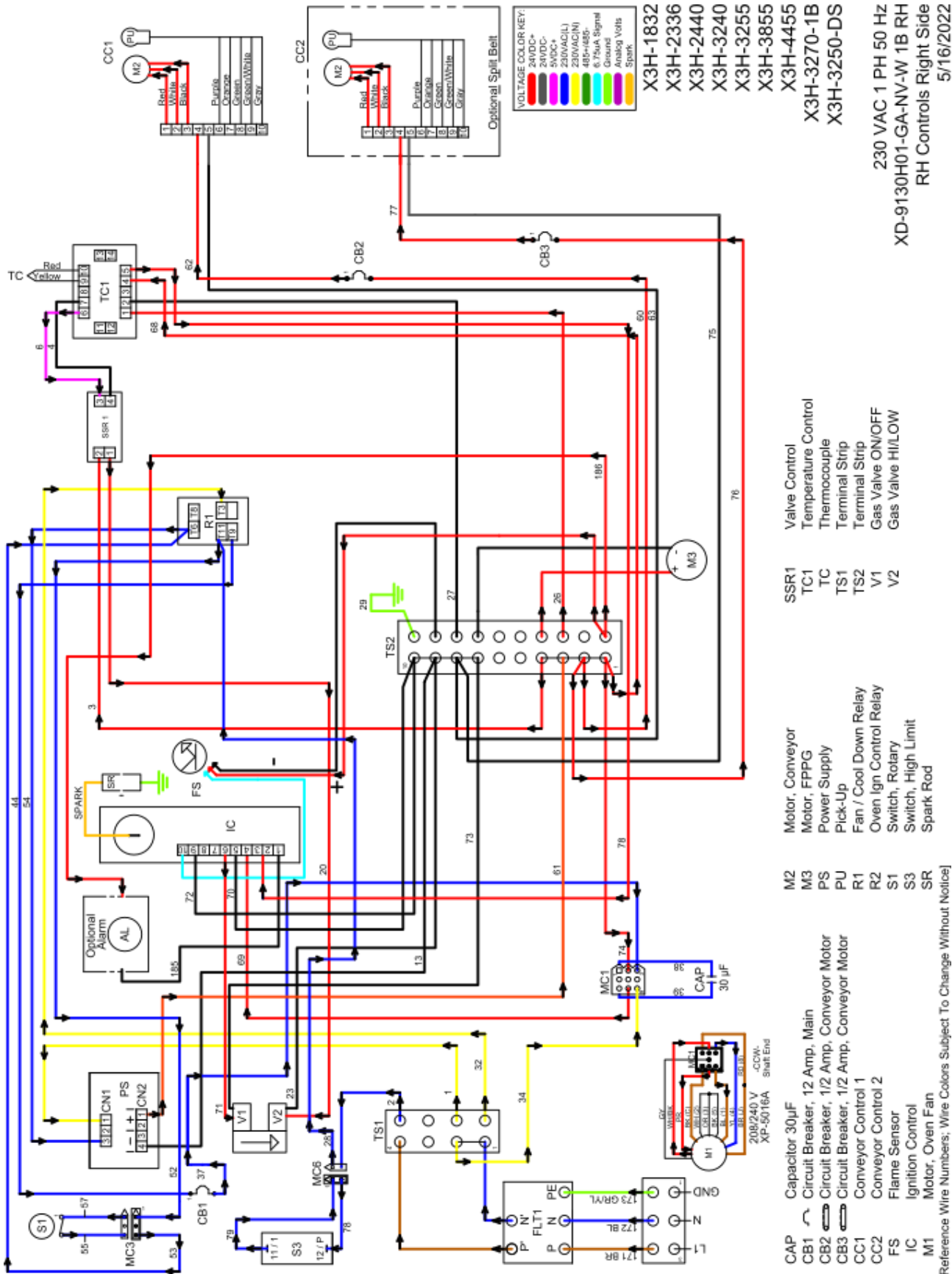

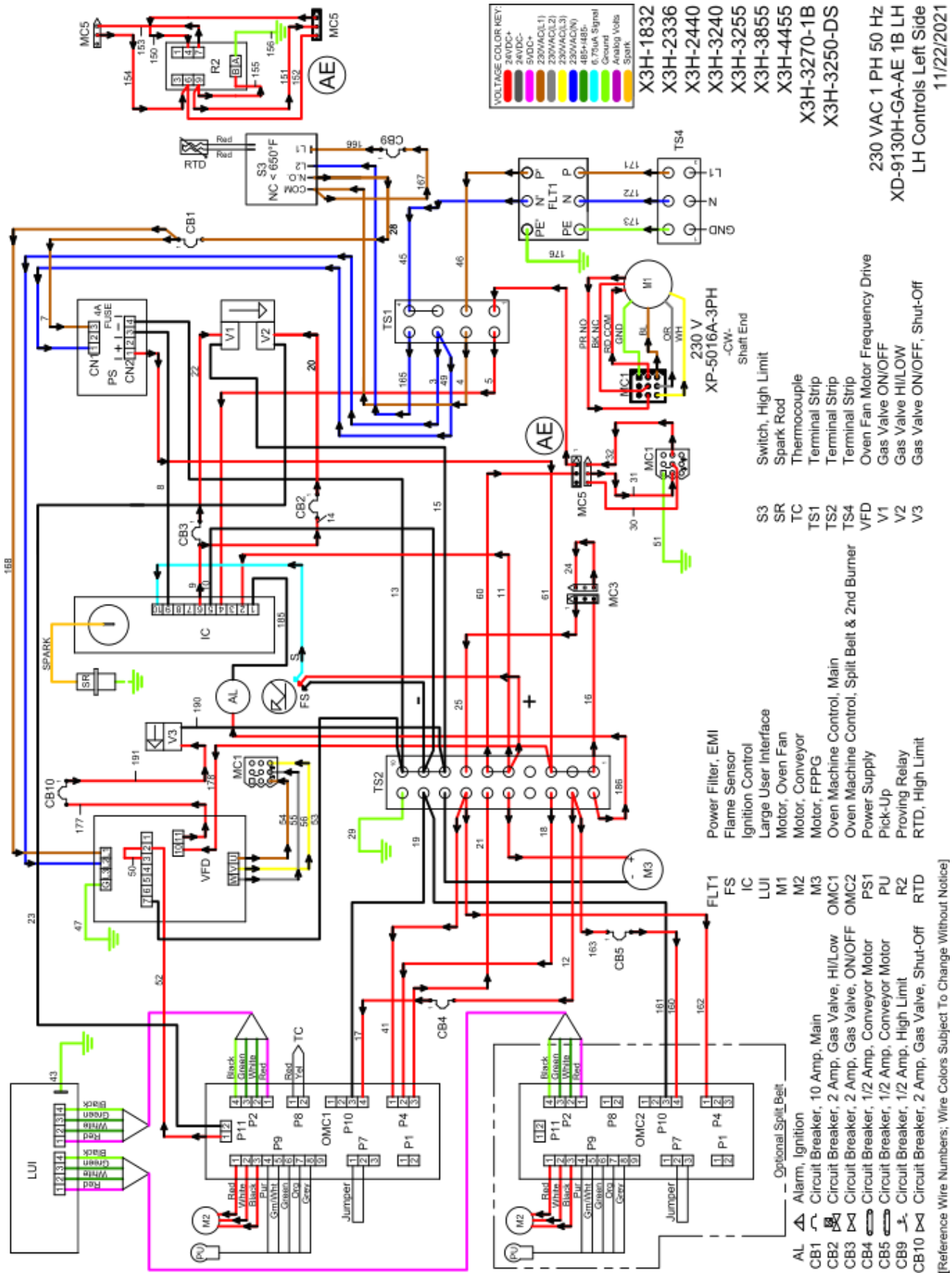

This page is intentionally left blank.

OVEN SCHEMATIC - AUSTRALIA NON VFD 1 BOX 230 VAC RH 125

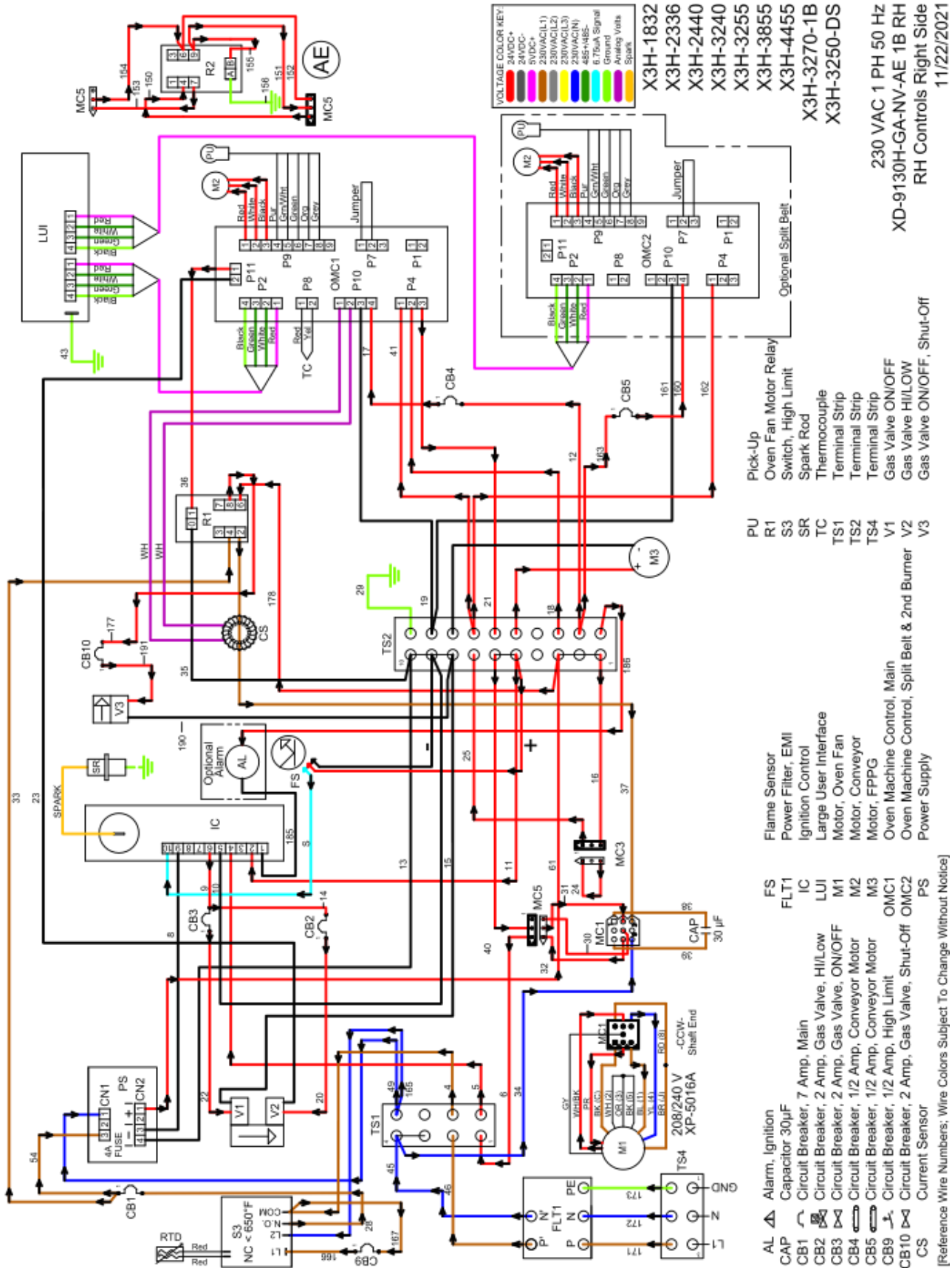

126 OVEN SCHEMATIC - STANDARD 2 BOX 120 VAC LHC LEFT SIDE

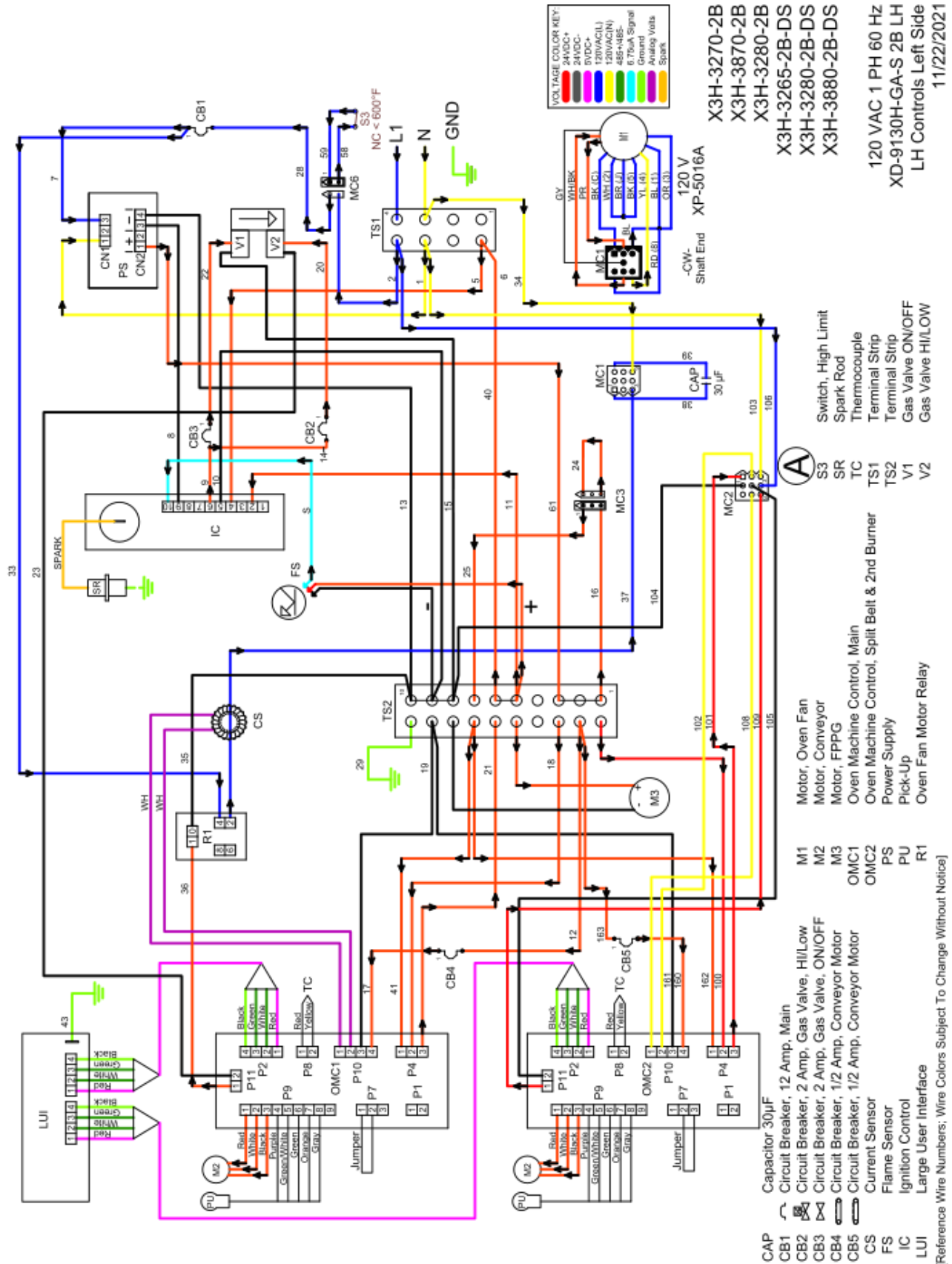

OVEN SCHEMATIC - STANDARD 2 BOX 120 VAC LHC RIGHT SIDE 127

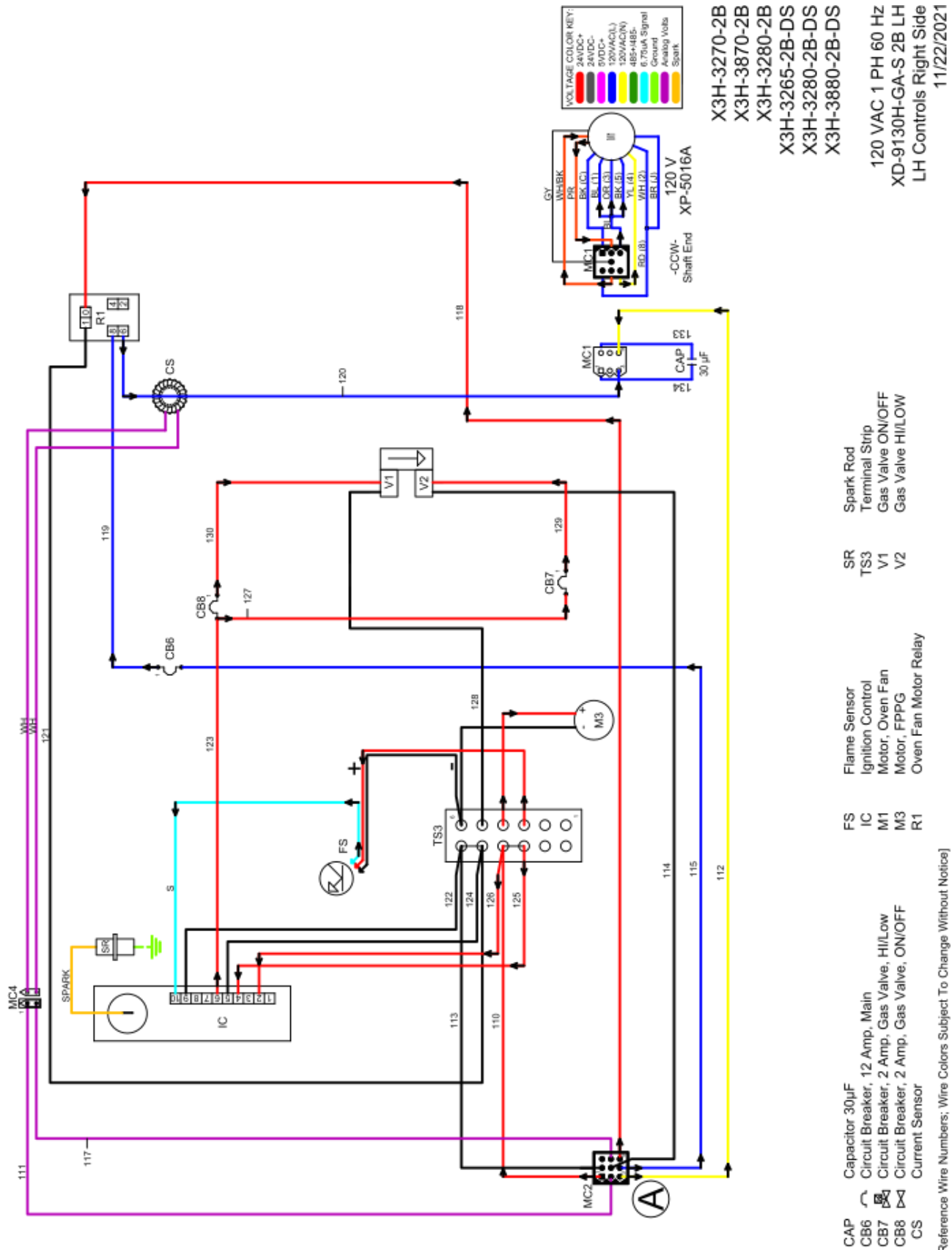

OVEN SCHEMATIC - STANDARD 2 BOX 120 VAC RHC RIGHT SIDE 129

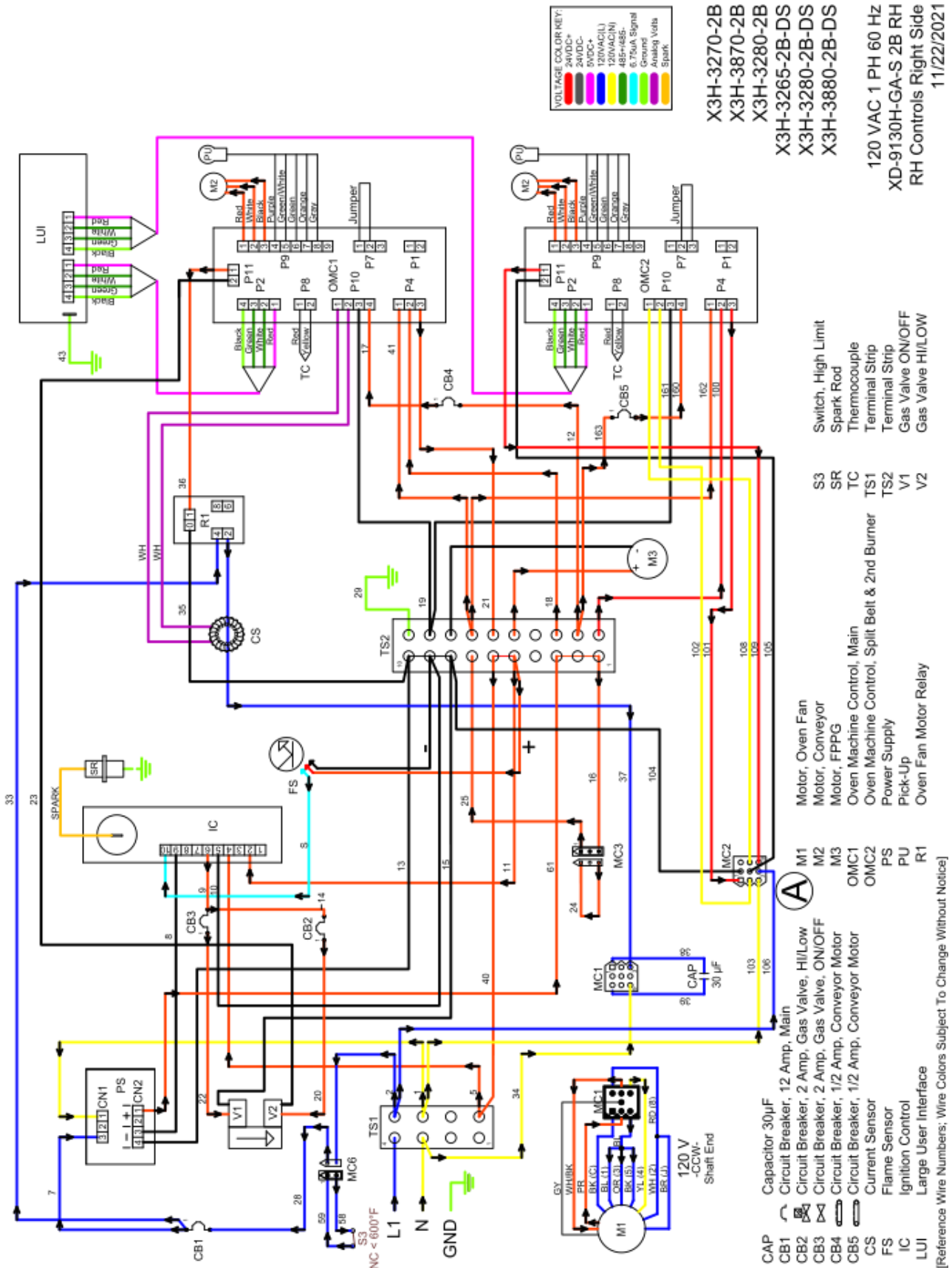

Technical Support US: 888-443-2751



Technical Support INTL: 316-943-2751

OVEN SCHEMATIC - STANDARD 2 BOX 120 VAC RHC RIGHT SIDE 131

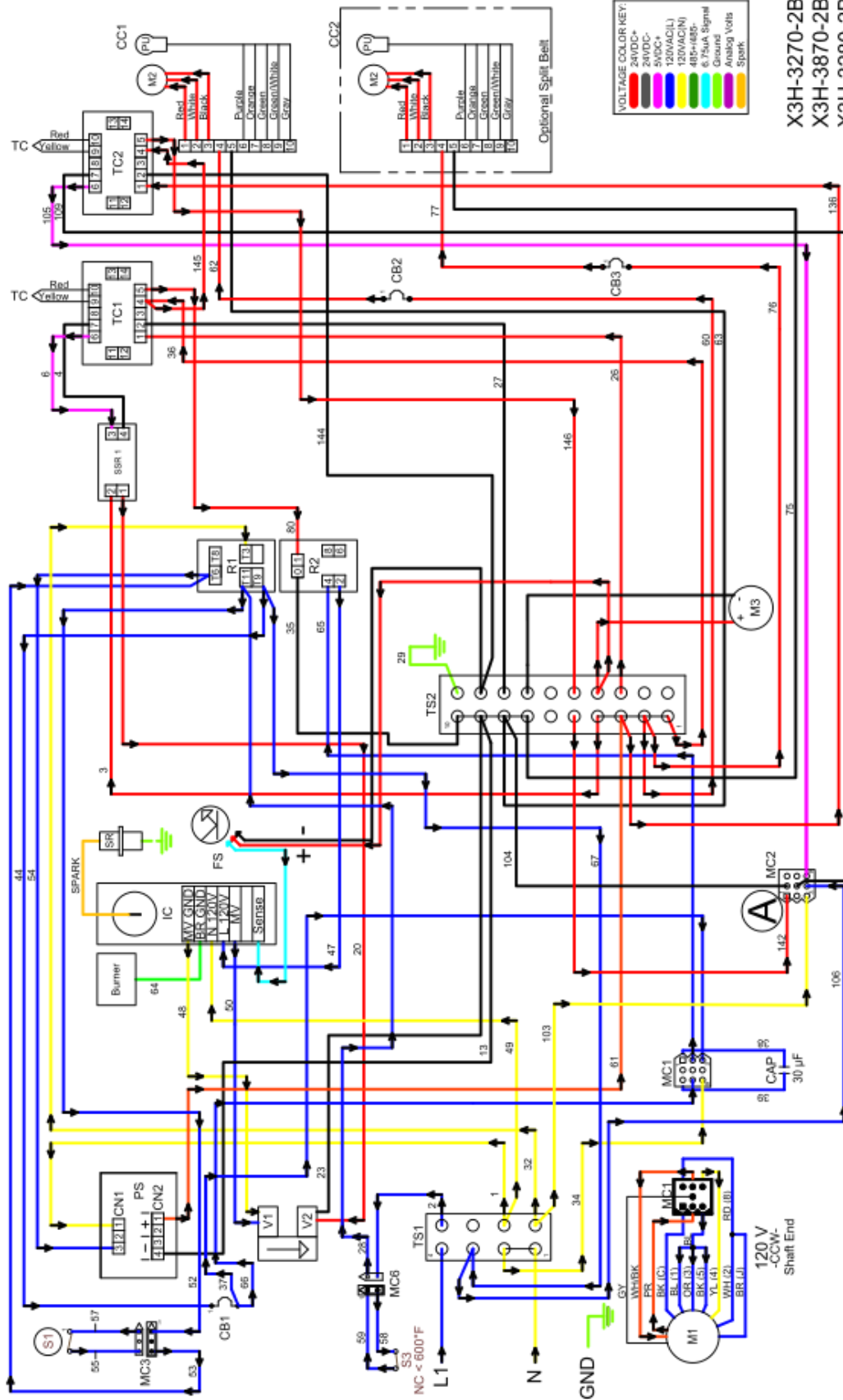

VOLTAGE COLOR KEY:

Red	120V AC/L
White	120V AC/N
Black	Ground
Purple	Signal
Orange	Signal
Green	Signal
Yellow	Signal
Blue	Signal
Grey	Signal

- X3H-3270-2B
- X3H-3870-2B
- X3H-3280-2B
- X3H-3265-2B-DS
- X3H-3280-2B-DS
- X3H-3880-2B-DS

120 VAC 1 PH 60 HZ
 XD-9130H01-GA-S 2B RH
 RH Controls Right Side
 5/16/2022

- CAP Capacitor 30µF
- CB1 Circuit Breaker, 12 Amp, Main
- CB2 Circuit Breaker, 1/2 Amp, Conveyor Motor
- CB3 Circuit Breaker, 1/2 Amp, Conveyor Motor
- CC1 Conveyor Control 1
- CC2 Conveyor Control 2
- FS Flame Sensor
- IC Ignition Control
- M1 Motor, Oven Fan
- M2 Motor, Conveyor
- M3 Motor, FPPG
- PS Power Supply
- Pick-Up Pick-Up
- R1 Fan / Cool Down Relay
- R2 Oven Ign Control Relay
- S1 Switch, Rotary
- S3 Switch, High Limit
- SR Spark Rod
- SSR1 SSR
- TC1 Temperature Control 1
- TC2 Temperature Control 2
- TC Thermocouple
- TS1 Terminal Strip
- TS2 Terminal Strip
- V1 Gas Valve ON/OFF
- V2 Gas Valve HI/LOW

(Reference Wire Numbers; Wire Colors Subject To Change Without Notice)



132 OVEN SCHEMATIC - WORLD 2 BOX 230 VAC LHC LEFT SIDE

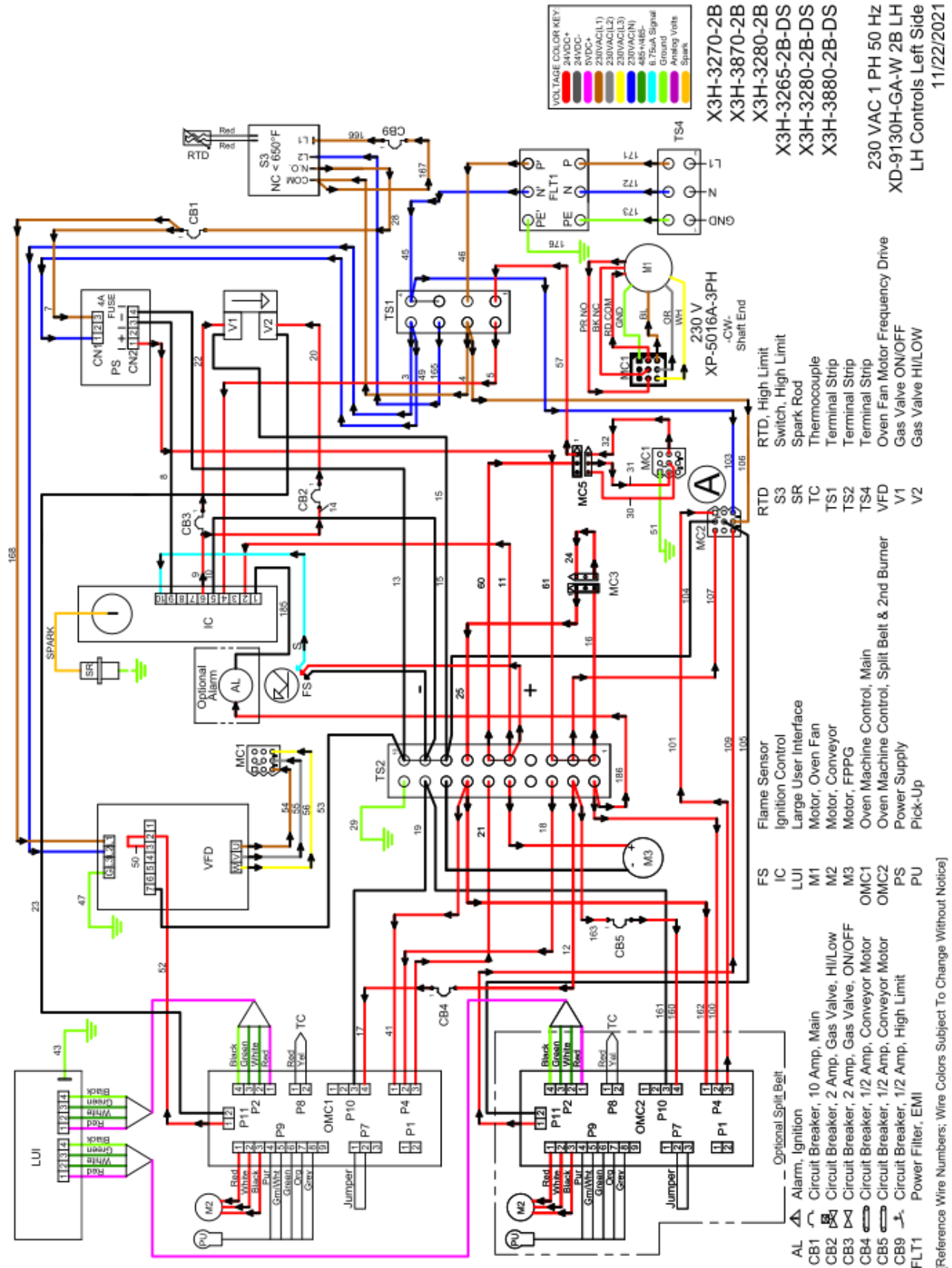

[Reference Wire Numbers; Wire Colors Subject To Change Without Notice]

230 VAC 1 PH 50 HZ
 XD-9130H-GA-W 2B LH
 LH Controls Left Side
 11/22/2021

OVEN SCHEMATIC - WORLD 2 BOX 230 VAC LHC RIGHT SIDE 133

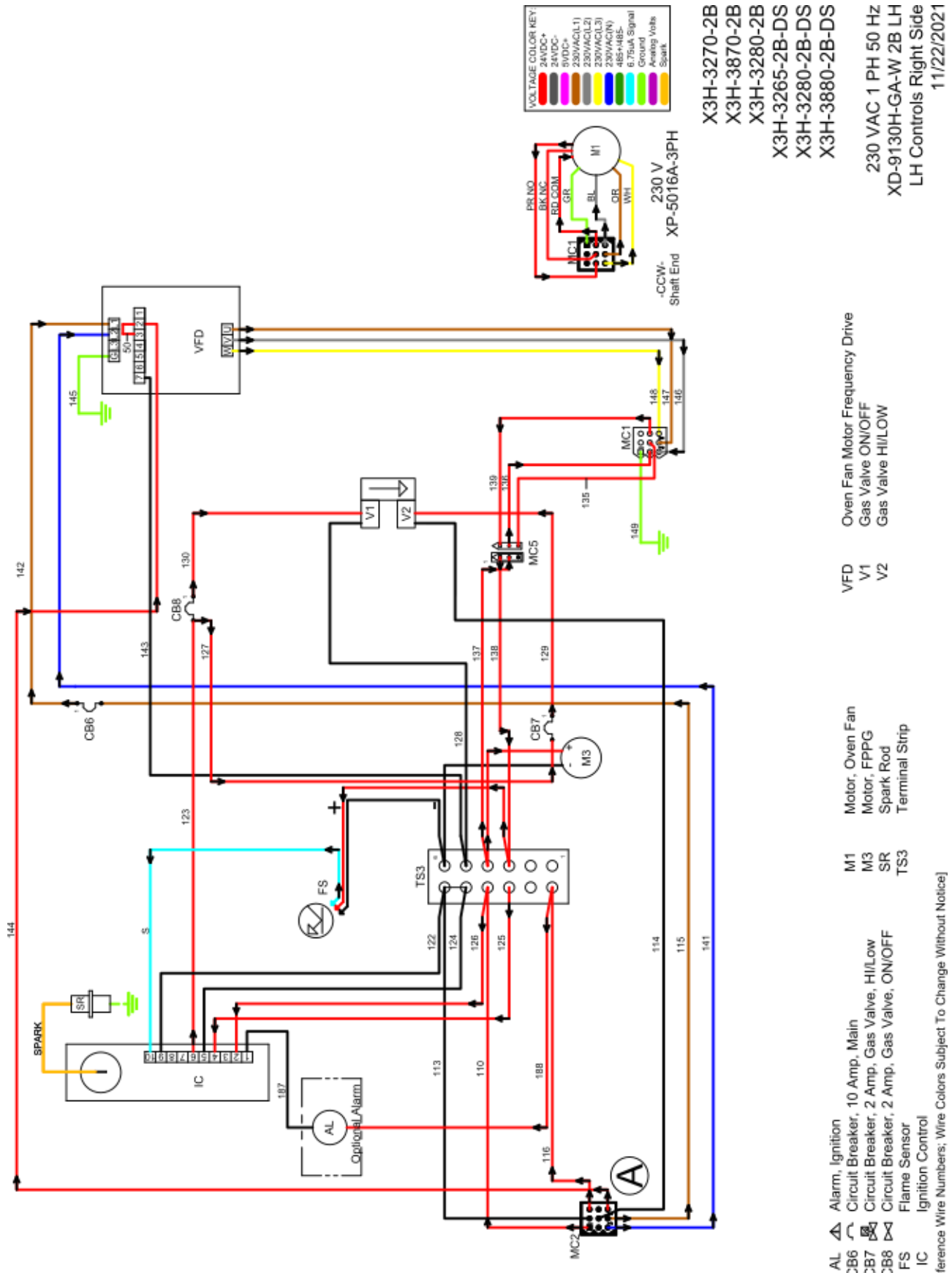

134 OVEN SCHEMATIC - WORLD 2 BOX 230 VAC RHC LEFT SIDE

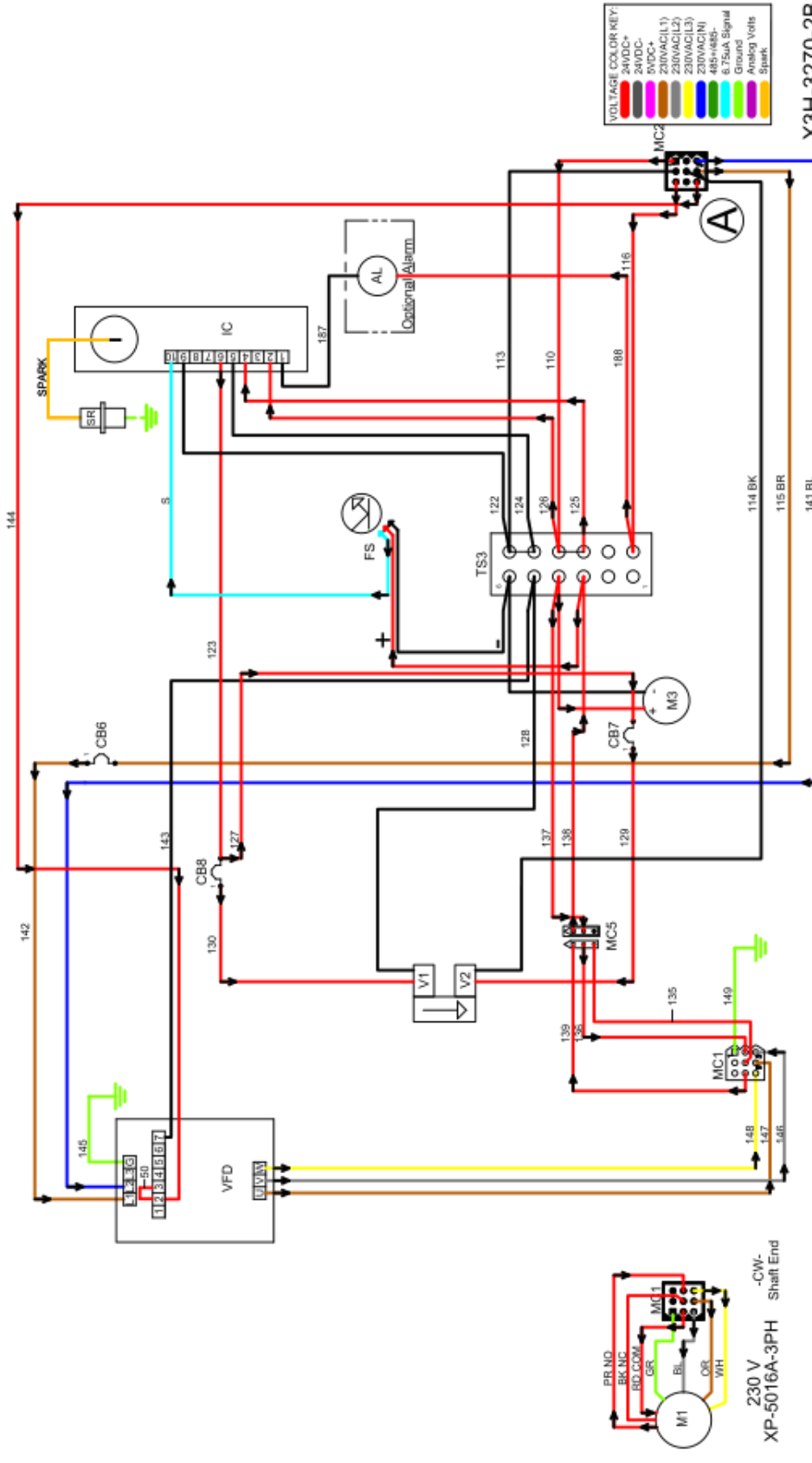

VOLTAGE	COLOR	REF
240VDC+	Red	
24VDC+	Pink	
50VDC+	Orange	
230VAC(L1)	Black	
230VAC(L2)	White	
230VAC(L3)	Blue	
230VAC(N)	Yellow	
485V+e6B+	Green	
6.75uA Signal	Light Green	
Ground	Light Blue	
50VDC	Light Purple	
Spark	Light Yellow	

- X3H-3270-2B
- X3H-3870-2B
- X3H-3280-2B
- X3H-3265-2B-DS
- X3H-3280-2B-DS
- X3H-3880-2B-DS

230 VAC 1 PH 50 HZ
 XD-9130H-GA-W 2B RH
 RH Controls Left Side
 11/22/2021

VFD Oven Fan Motor Frequency Drive
 V1 Gas Valve ON/OFF
 V2 Gas Valve HI/LOW

M1 Motor, Oven Fan
 M3 Motor, FPPG
 SR Spark Rod
 TS3 Terminal Strip

AL Alarm, Ignition
 CB6 Circuit Breaker, 10 Amp, Main
 CB7 Circuit Breaker, 2 Amp, Gas Valve, HI/LOW
 CB8 Circuit Breaker, 2 Amp, Gas Valve, ON/OFF
 FS Flame Sensor
 IC Ignition Control

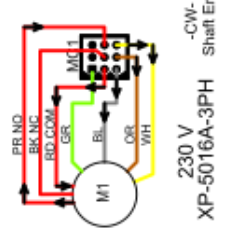

230 V XP-5016A-3PH -CW- Shaft End

[Reference Wire Numbers; Wire Colors Subject To Change Without Notice]



OVEN SCHEMATIC - WORLD 2 BOX 230 VAC RHC RIGHT SIDE 135

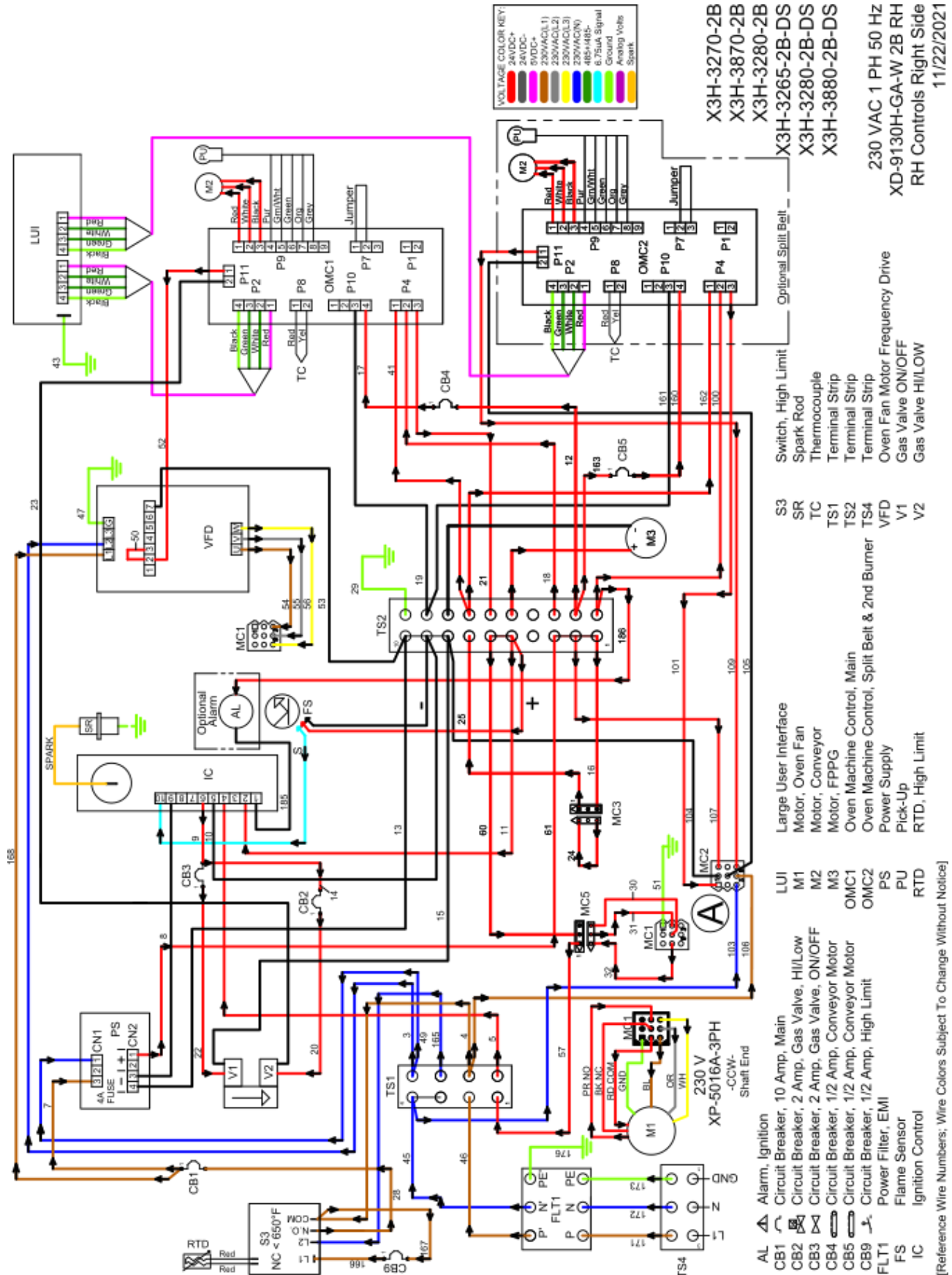

136 OVEN SCHEMATIC - WORLD 2 BOX 230 VAC RHC LEFT SIDE

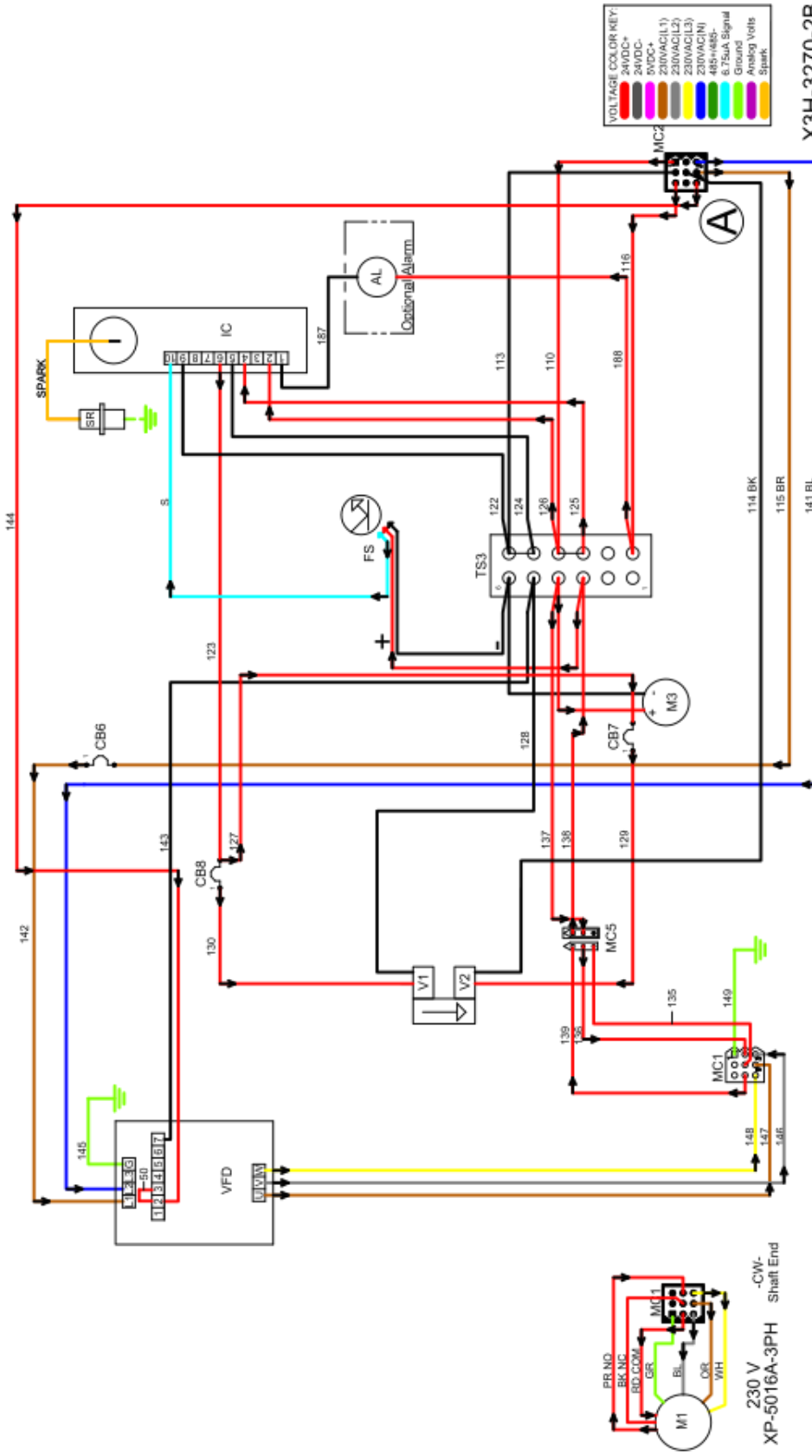

VOLTAGE COLOR KEY:

Red	240VDC
Pink	24VDC
White	0VDC
Black	230VAC(L1)
Blue	230VAC(L2)
Yellow	230VAC(L3)
Green	230VAC(N)
Light Blue	48V+eSR
Light Green	6.75uA Signal
Light Yellow	Alarm Vols
Light Purple	Spark

- X3H-3270-2B
- X3H-3870-2B
- X3H-3280-2B
- X3H-3265-2B-DS
- X3H-3280-2B-DS
- X3H-3880-2B-DS

230 VAC 1 PH 50 HZ
 XD-9130H-GA-W 2B RH
 RH Controls Left Side
 11/22/2021

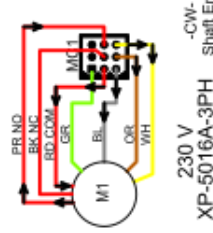

- AL Alarm, Ignition
- CB6 Circuit Breaker, 10 Amp, Main
- CB7 Circuit Breaker, 2 Amp, Gas Valve, HI/LOW
- CB8 Circuit Breaker, 2 Amp, Gas Valve, ON/OFF
- FS Flame Sensor
- IC Ignition Control
- M1 Motor, Oven Fan
- M3 Motor, FPPG
- SR Spark Rod
- TS3 Terminal Strip
- VFD Oven Fan Motor Frequency Drive
- V1 Gas Valve ON/OFF
- V2 Gas Valve HI/LOW

[Reference Wire Numbers; Wire Colors Subject To Change Without Notice]



This page is intentionally left blank.

138 OVEN SCHEMATIC - WORLD NON VFD 2 BOX 230 VAC RHC LEFT SIDE

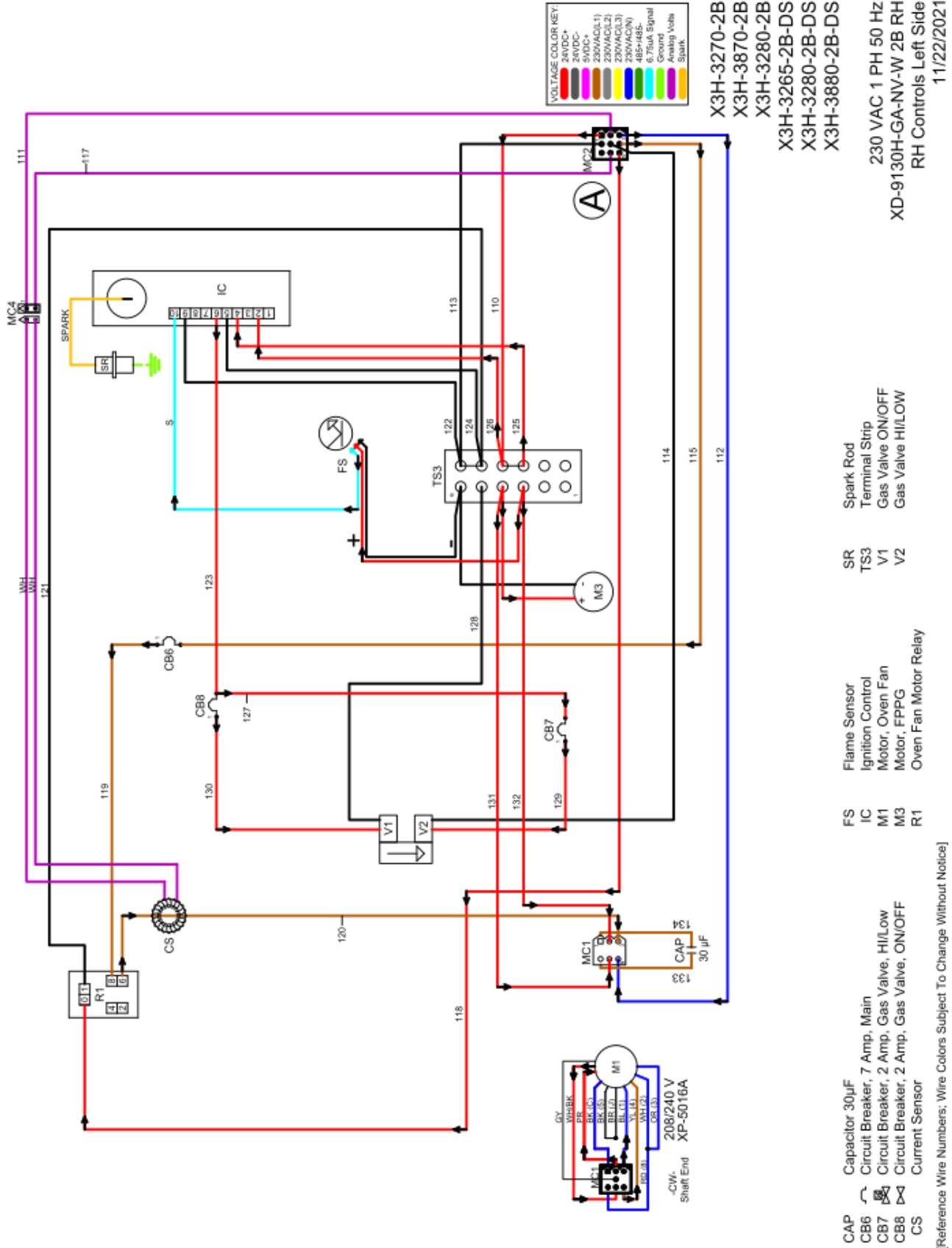

140 OVEN SCHEMATIC - WORLD NON VFD 2 BOX 230 VAC RHC LEFT SIDE

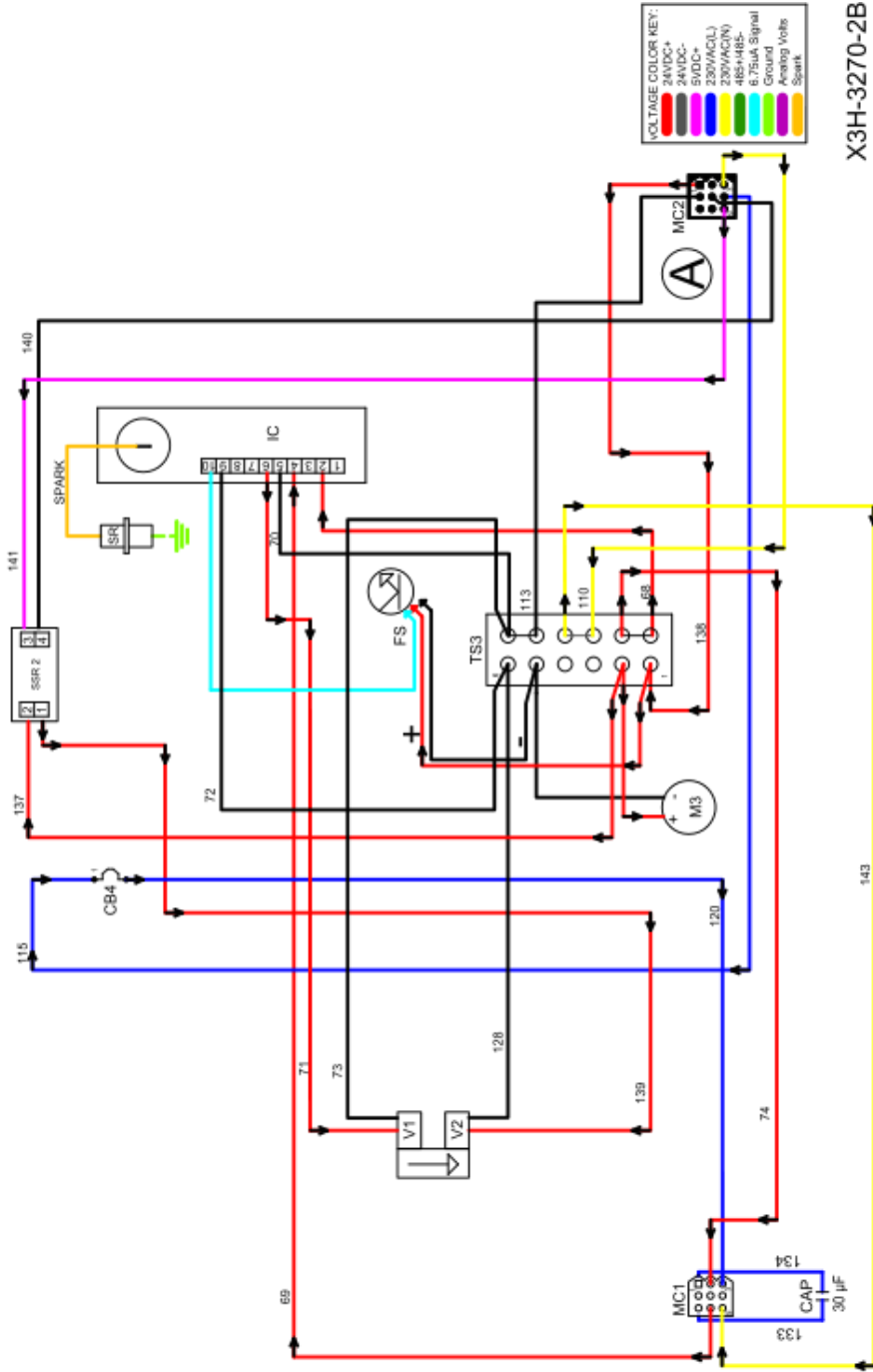

VOLTAGE COLOR KEY:

Red	24VDC+
Black	24VDC-
White	5VDC+
Blue	230VAC(L)
Yellow	230VAC(N)
Green	6-12VDC
Light Green	Signal
Dark Green	Ground
Purple	Analog Volts
Orange	Spark

- X3H-3270-2B
- X3H-3870-2B
- X3H-3280-2B
- X3H-3265-2B-DS
- X3H-3280-2B-DS
- X3H-3880-2B-DS

230 VAC 1 PH 50 Hz
 XD-9130H01-GA-NV-W 2B RH
 RH Controls Left Side
 5/16/2022

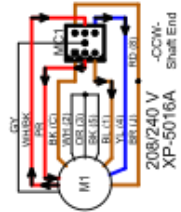

- CAP Capacitor 30µF
- CB4 Circuit Breaker, 12 Amp, Main
- FS Flame Sensor
- IC Ignition Control
- M1 Motor, Oven Fan
- M3 Motor, FPPG
- R1 Oven Ign Control Relay
- SR Spark Rod
- SSR2 Valve Control
- TS3 Terminal Strip
- V1 Gas Valve ON/OFF
- V2 Gas Valve HI/LOW

[Reference Wire Numbers; Wire Colors Subject To Change Without Notice]



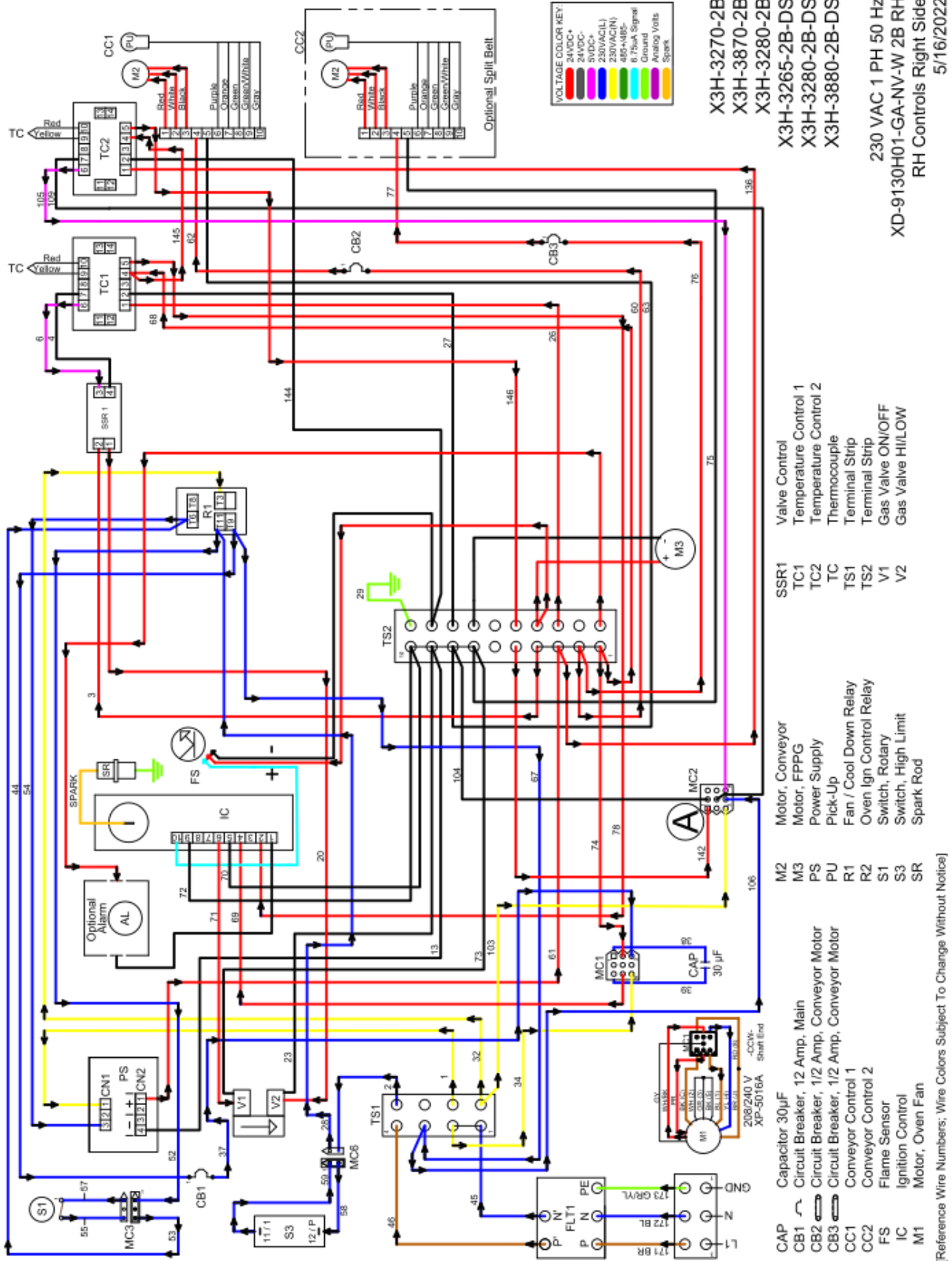

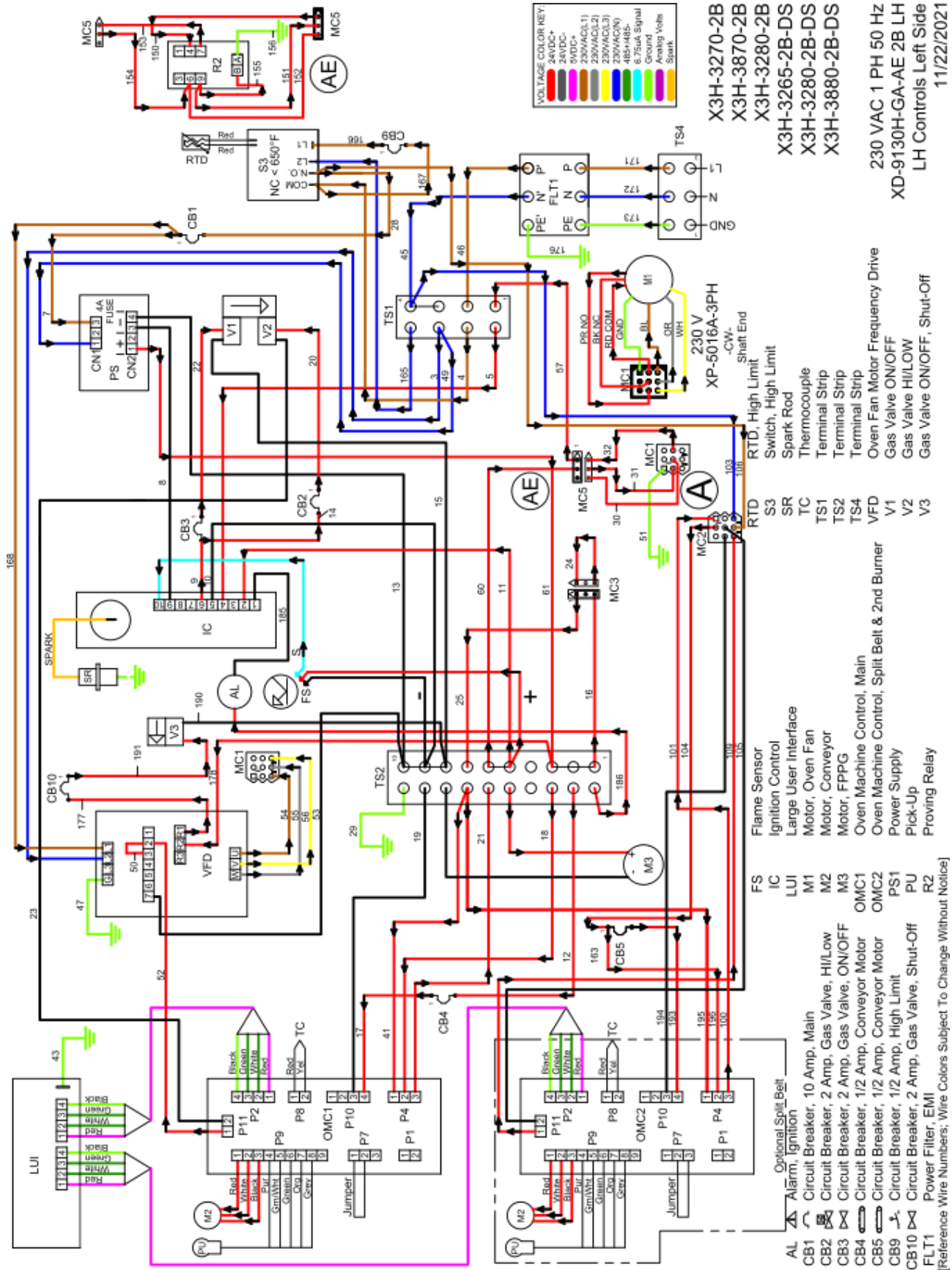

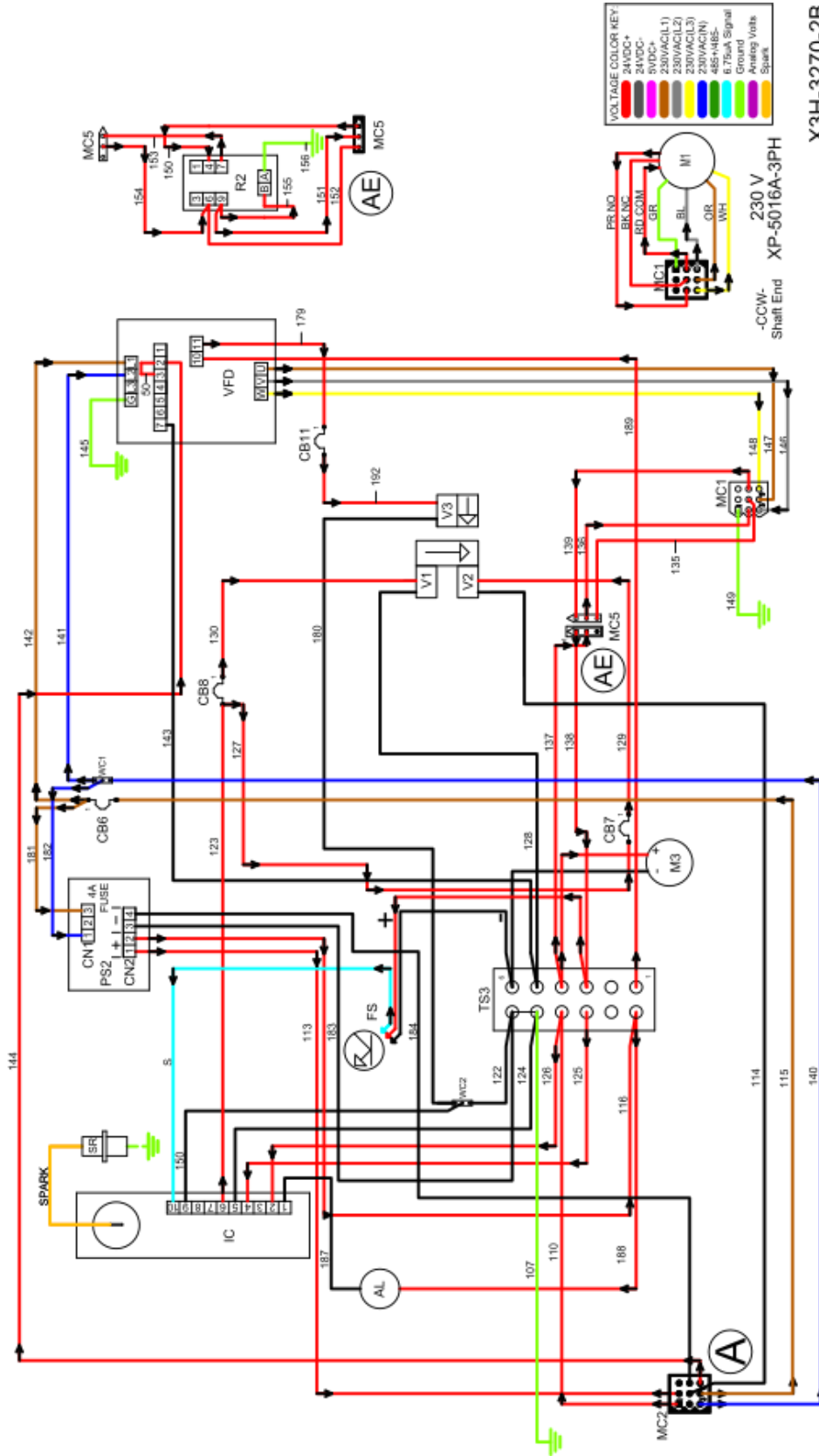

- X3H-3270-2B
- X3H-3870-2B
- X3H-3280-2B
- X3H-3265-2B-DS
- X3H-3280-2B-DS
- X3H-3880-2B-DS

230 VAC 1 PH 50 Hz
 XD-9130H-GA-AE 2B LH
 LH Controls Right Side
 11/22/2021

- VFD Oven Fan Frequency Drive
- V1 Gas Valve ON/OFF
- V2 Gas Valve HI/LOW
- V3 Gas Valve ON/OFF, Shut-Off
- WC1 Wago Connector
- WC2 Wago Connector

- M1 Motor, Oven Fan
- M3 Motor, FPPG
- PS2 Power Supply
- R2 Proving Relay
- SR Spark Rod
- TS3 Terminal Strip

- AL Alarm, Ignition
- CB6 Circuit Breaker, 10 Amp, Main
- CB7 Circuit Breaker, 2 Amp, Gas Valve, HI/LOW
- CB8 Circuit Breaker, 2 Amp, Gas Valve, ON/OFF
- CB11 Circuit Breaker, 2 Amp, Gas Valve, Shut-Off
- FS Flame Sensor
- IC Ignition Control

[Reference Wire Numbers; Wire Colors Subject To Change Without Notice]



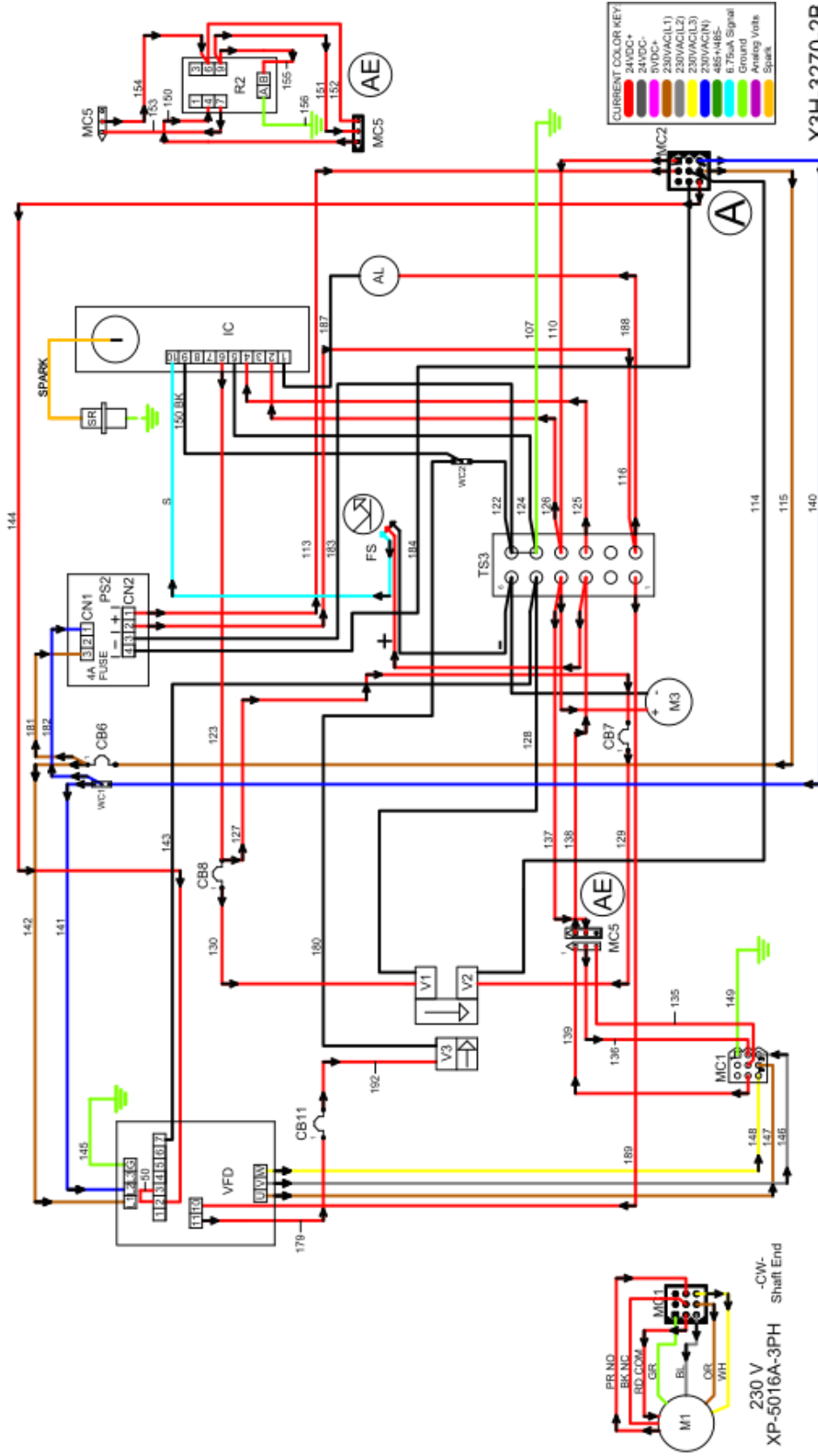

CURRENT COLOR KEY

Red	24VDC+
Black	24VDC-
White	5VDC+
Blue	230VAC(L1)
Orange	230VAC(L2)
Green	230VAC(L3)
Yellow	230VAC(N)
Purple	485+48S-
Light Blue	6750A Signal
Light Green	Archie's Valve
Light Purple	Spark

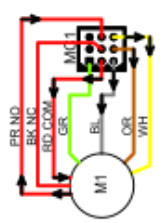

- X3H-3270-2B
- X3H-3870-2B
- X3H-3280-2B
- X3H-3265-2B-DS
- X3H-3280-2B-DS
- X3H-3880-2B-DS

230 VAC 1 PH 50 HZ
 XD-9130H-GA-AE 2B RH
 RH Controls Left Side
 11/22/2021

- VFD Oven Fan Motor Frequency Drive
- V1 Gas Valve ON/OFF
- V2 Gas Valve HI/LOW
- V3 Gas Valve ON/OFF, Shut-Off
- WC1 Wago Connector
- WC2 Wago Connector

- M1 Motor, Oven Fan
- M3 Motor, FPPG
- PS2 Power Supply
- R2 Proving Relay
- SR Spark Rod
- TS3 Terminal Strip

- AL Alarm, Ignition
- CB6 Circuit Breaker, 10 Amp, Main
- CB7 Circuit Breaker, 2 Amp, Gas Valve, HI/LOW
- CB8 Circuit Breaker, 2 Amp, Gas Valve, ON/OFF
- CB11 Circuit Breaker, 2 Amp, Gas Valve, Shut-Off
- FS Flame Sensor
- IC Ignition Control

[Reference Wire Numbers; Wire Colors Subject To Change Without Notice]

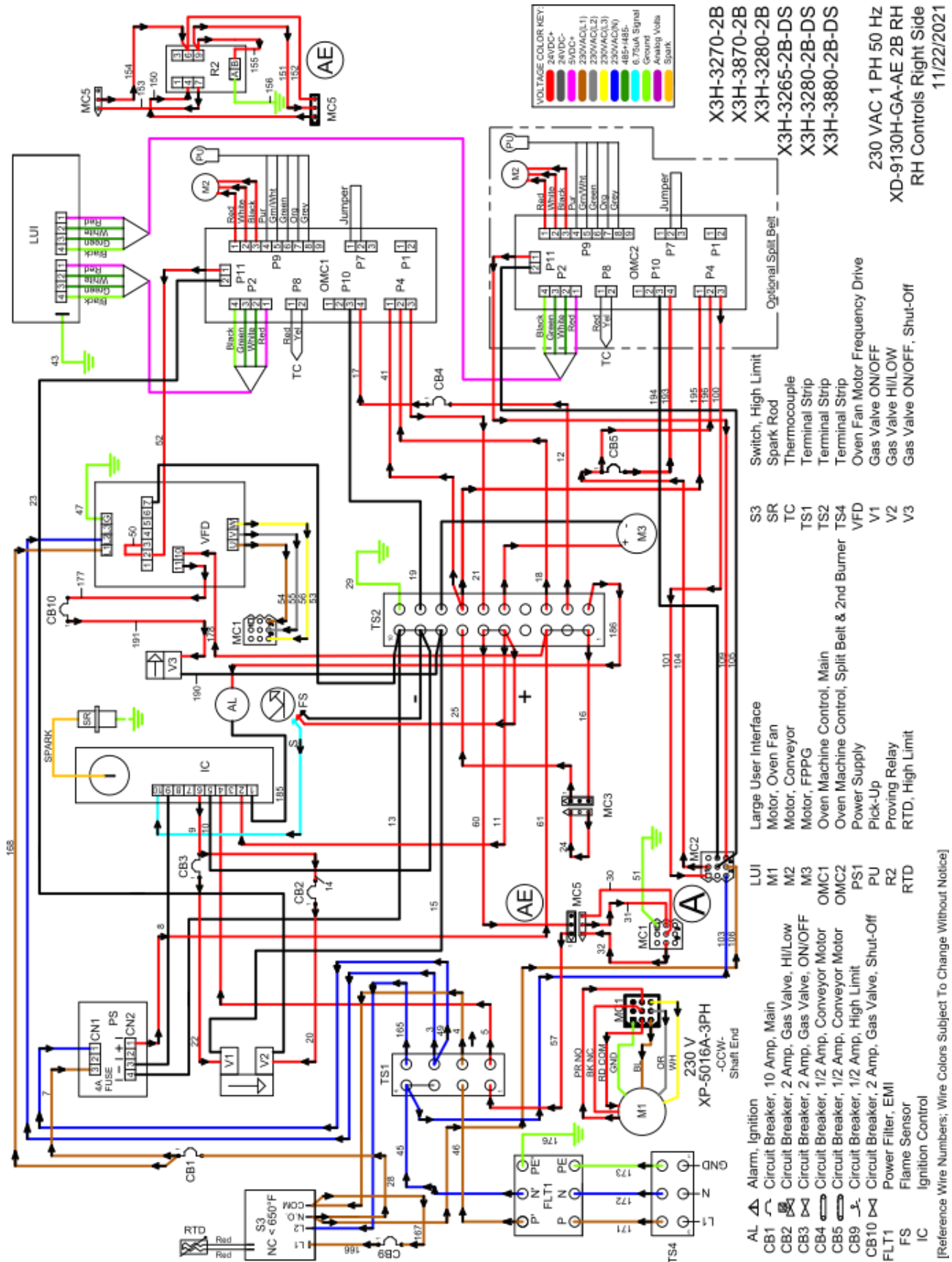

146 OVEN SCHEMATIC - AUSTRALIA NON VFD 2 BOX 230 VAC RHC LEFT SIDE

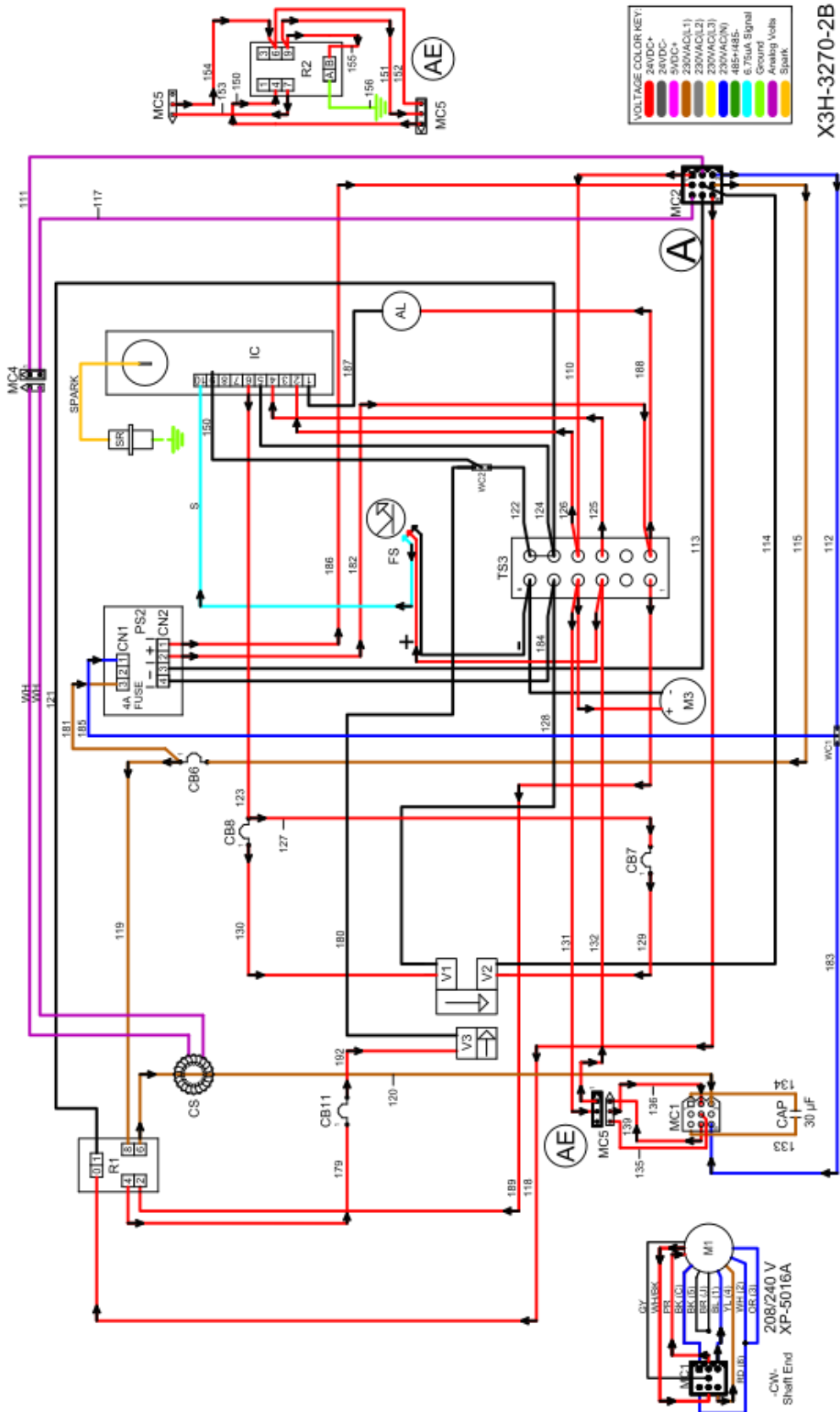

VOLTAGE COLOR KEY:

- 24VDC+
- 24VDC-
- 5VDC+
- 230VAC(L1)
- 230VAC(L2)
- 230VAC(L3)
- 230VAC(N)
- 485+485-
- 6.75uA Signal
- Ground
- Analog Vols
- Spark

- X3H-3270-2B
- X3H-3870-2B
- X3H-3280-2B
- X3H-3265-2B-DS
- X3H-3280-2B-DS
- X3H-3880-2B-DS

230 VAC 1 PH 50 Hz
 XD-9130H-GA-NV-AE 2B RH
 RH Controls Left Side
 11/22/2021

- V1 Gas Valve ON/OFF
- V2 Gas Valve HI/LOW
- V3 Gas Valve ON/OFF, Shut-Off
- WC1 Wago Connector
- WC2 Wago Connector

- IC Ignition Control
- M1 Motor, Oven Fan
- M3 Motor, FPPG
- R1 Oven Fan Motor Relay
- R2 Proving Relay
- SR Spark Rod
- TS3 Terminal Strip

- CAP Capacitor 30µF
- CB6 Circuit Breaker, 7 Amp, Main
- CB7 Circuit Breaker, 2 Amp, Gas Valve, HI/LOW
- CB8 Circuit Breaker, 2 Amp, Gas Valve, ON/OFF
- CB11 Circuit Breaker, 2 Amp, Gas Valve, Shut-Off
- CS Current Sensor
- FS Flame Sensor

[Reference Wire Numbers; Wire Colors Subject To Change Without Notice]



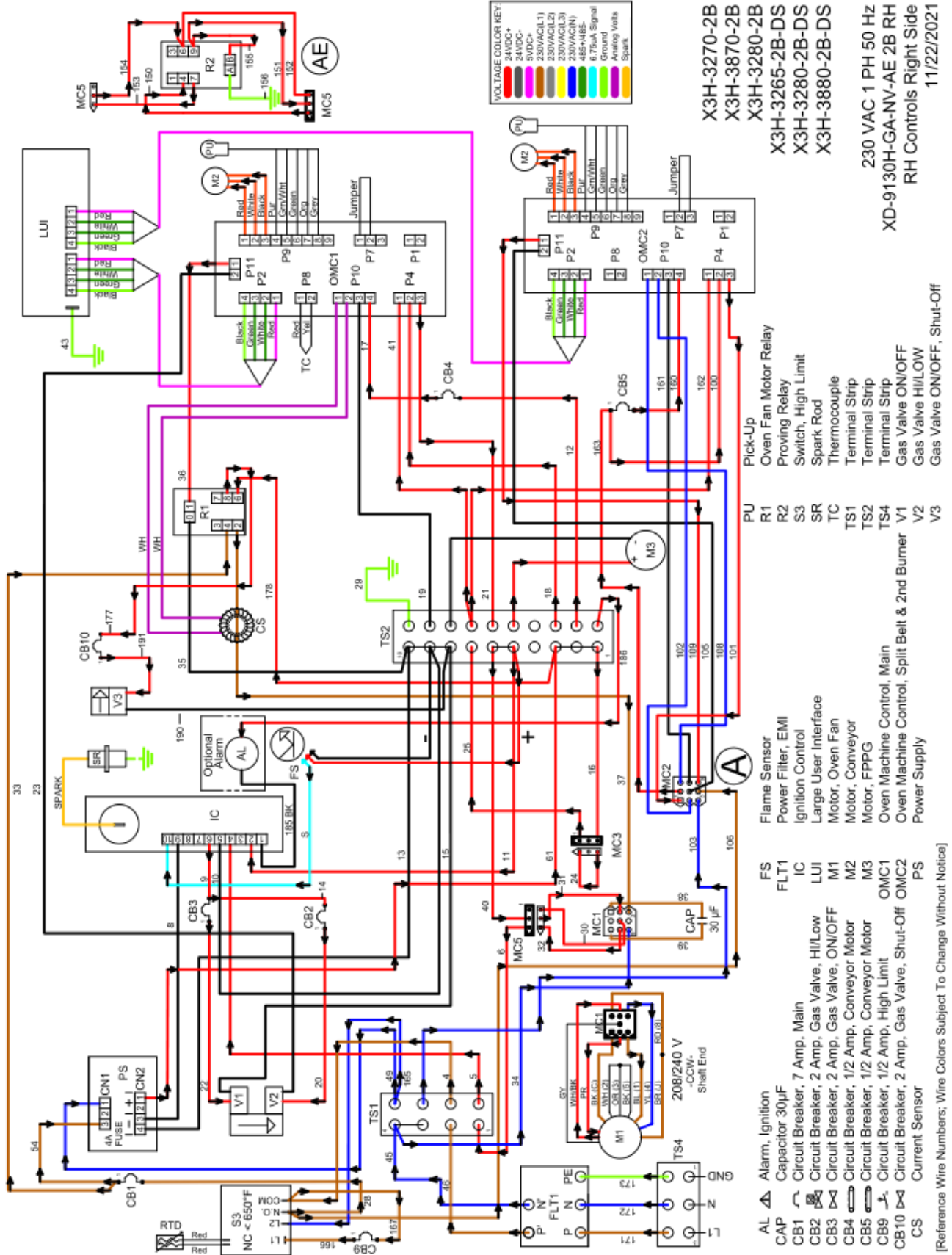

[Reference Wire Numbers; Wire Colors Subject To Change Without Notice]

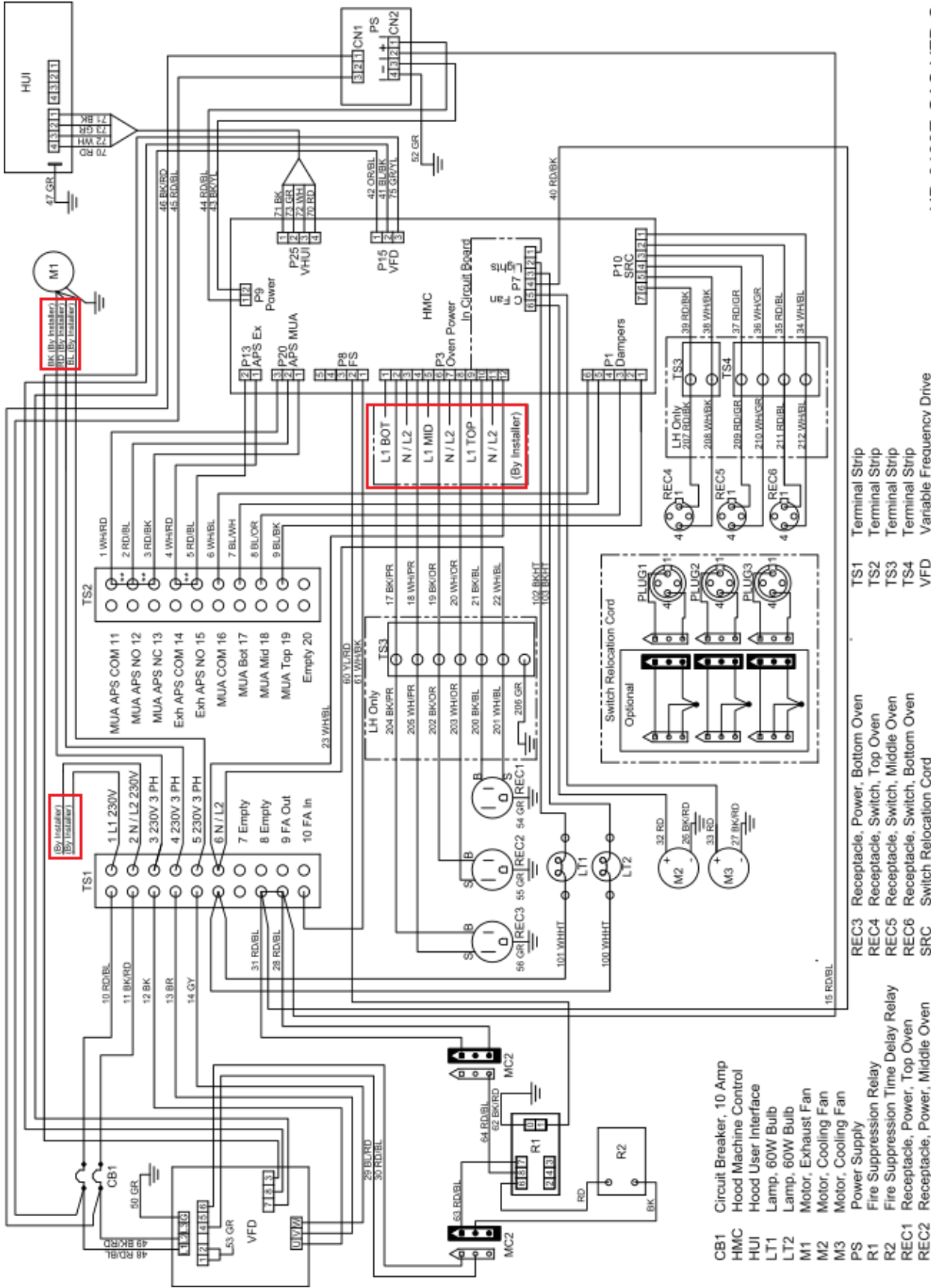

HD-9130E-GAS-VFD-S
11/20/2020

** - Remove Jumpers for APS

GY-Gray

WH-White

OR-Orange

HT-High Temp

PR-Purple

YL-Yellow

GR-Green

BR-Brown

BL-Blue

BK-Black

- CB1 Circuit Breaker, 10 Amp
- HMC Hood Machine Control
- HUI Hood User Interface
- LT1 Lamp, 60W Bulb
- LT2 Lamp, 60W Bulb
- M1 Motor, Exhaust Fan
- M2 Motor, Cooling Fan
- M3 Motor, Cooling Fan
- PS Power Supply
- R1 Fire Suppression Relay
- R2 Fire Suppression Time Delay Relay
- REC1 Receptacle, Power, Top Oven
- REC2 Receptacle, Power, Middle Oven
- REC3 Receptacle, Power, Bottom Oven
- REC4 Receptacle, Switch, Top Oven
- REC5 Receptacle, Switch, Middle Oven
- REC6 Receptacle, Switch, Bottom Oven
- SRC Switch Relocation Card
- TS1 Receptacle, Power, Bottom Oven
- TS2 Receptacle, Switch, Top Oven
- TS3 Receptacle, Switch, Middle Oven
- TS4 Receptacle, Switch, Bottom Oven
- VFD Variable Frequency Drive



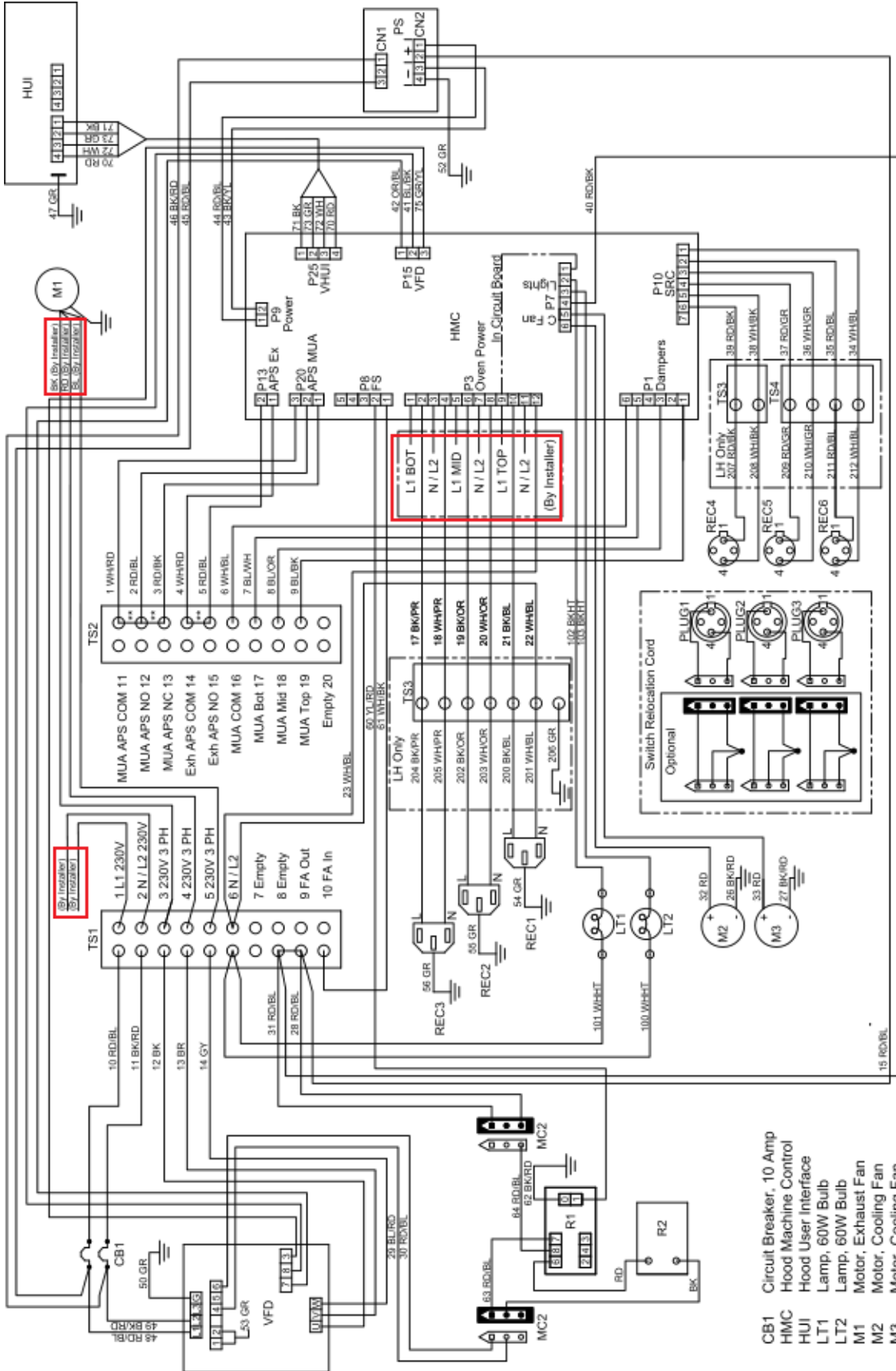

HD-9130E-GAS-VFD-W
11/20/2020

** - Remove Jumpers for APS

GY-Gray

WH-White

OR-Orange

HT-High Temp

PR-Purple

YL-Yellow

GR-Green

BR-Brown

BL-Blue

TS1 Terminal Strip

TS2 Terminal Strip

TS3 Terminal Strip

TS4 Terminal Strip

VFD Variable Frequency Drive

REC3 Receptacle, Power, Bottom Oven

REC4 Receptacle, Switch, Top Oven

REC5 Receptacle, Switch, Middle Oven

REC6 Receptacle, Switch, Bottom Oven

- CB1 Circuit Breaker, 10 Amp
- HMC Hood Machine Control
- HUI Hood User Interface
- LT1 Lamp, 60W Bulb
- LT2 Lamp, 60W Bulb
- M1 Motor, Exhaust Fan
- M2 Motor, Cooling Fan
- M3 Motor, Cooling Fan
- PS Power Supply
- R1 Fire Suppression Relay
- R2 Fire Suppression Time Delay Relay
- REC1 Receptacle, Power, Top Oven
- REC2 Receptacle, Power, Middle Oven

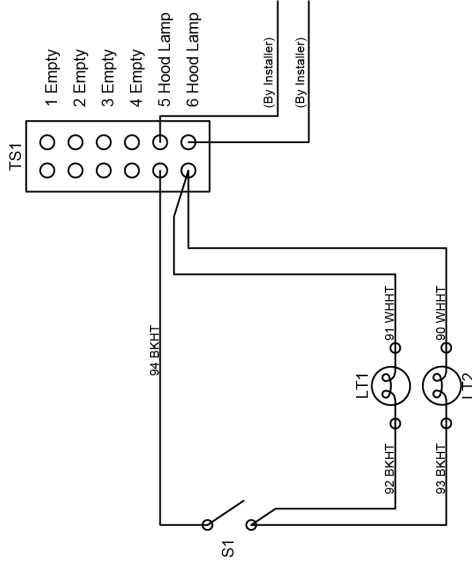
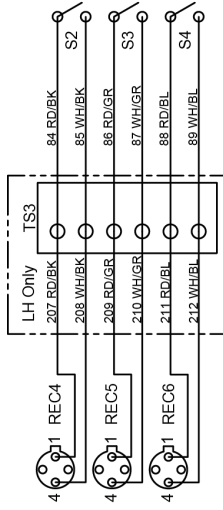

- LT1 Lamp, 60W Bulb
- LT2 Lamp, 60W Bulb
- REC4 Receptacle, Top Oven
- REC5 Receptacle, Middle Oven
- REC6 Receptacle, Bottom Oven
- S1 Switch, Light
- S2 Switch, Top Oven
- S3 Switch, Middle Oven
- S4 Switch, Bottom Oven
- TS1 Terminal Strip
- TS3 Terminal Strip

HD-9130E-NV
03/16/2017

RD-Red BK-Black BL-Blue GR-Green HT-High Temp WH-White

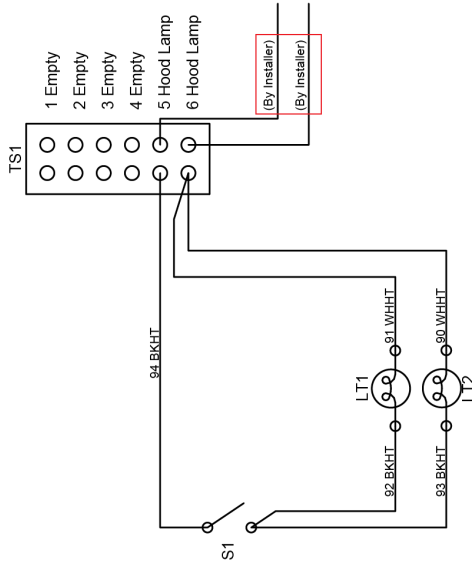
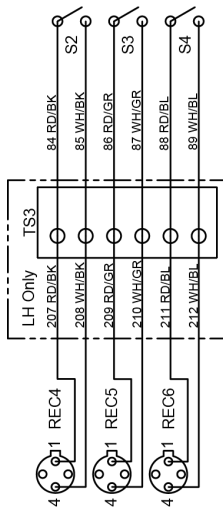

- LT1 Lamp, 60W Bulb
- LT2 Lamp, 60W Bulb
- REC4 Receptacle, Top Oven
- REC5 Receptacle, Middle Oven
- REC6 Receptacle, Bottom Oven
- S1 Switch, Light
- S2 Switch, Top Oven
- S3 Switch, Middle Oven
- S4 Switch, Bottom Oven
- TS1 Terminal Strip
- TS3 Terminal Strip

HD-9130E-NV
03/16/2017

RD-Red BK-Black BL-Blue GR-Green HT-High Temp WH-White

Product Certifications and Applicable Codes

Standard XLT Oven Certifications¹:

XLT Gas Ovens:

1. ANSI Z83.11-2016/CSA 1.8-2016 Standard for Gas Food Service Equipment
2. ANSI/NSF 4-2016 Sanitation for Commercial Cooking Rethermalization & Powered Hot Food Holding & Transportation Equipment

World XLT Oven Certifications¹:

XLT Gas Ovens:

1. EN 60335-1:2002 +A11, A1:2004 +A12, A2:2006 +A1 Low Voltage Directive (LVD)
2. EN 55014-1:2006 +A1:2009 +A2:2011 EN 61000-3-2:2018, EN 61000-3-3:2013 Electromagnetic Compatibility. (EMC)
3. EN 55014-2:2015 Conducted Emissions, Surge Immunity
4. BS EN 203-1:2014, Gas Heated Catering Equipment; General Safety Rules
5. BS EN 203-2-1:2006, Standard for Gas Heated Catering Equipment; Specific Requirements Ovens
6. BS EN 203-3:2009, Gas Heated Catering Equipment; Materials and Parts in Contact with Food and Other Sanitary Aspects
7. EN 60335-2-102:2004 +A1:2008 +A2:2012 Gas Appliance Regulation (GAR)

Australian XLT Oven Certifications²:

XLT Gas Ovens: (Certificate GAS40066)

1. AS 4563-2004 Commercial Catering Gas Equipment
2. AS/NZ 3350.1:2002 Safety of Household & Similar Appliances

Korea XLT Oven Certifications³:

XLT Gas Ovens: (Certificate GA-107)

1. Meets KGS-AB338 Facility/Technical/Inspection Code For Manufacture of Commercial Gas Burning Appliances.

Standard & World XLT Hood Certifications¹:

1. UL 710 Standard for Safety Exhaust Hoods for Commercial Cooking
2. ANSI/NSF 2:2014 Sanitation Food Equipment
3. ULC-S646, Standard for Exhaust Hoods and Related Controls for Commercial and Institutional Kitchens

¹ The noted certifications for XLT ovens and XLT Hood are performed and documented by Intertek Testing Services NA Inc. 165 Main Street, Cortland, NY 13045. Intertek is a nationally and internationally certified testing and accreditation agency.

² The certifications for Australia are administered and verified by the SAI Global Pty Limited 680 George Street, Sydney NSW 2000, GPO Box 5420 Sydney NSW 2001

³ 402 Hannuri-daero, Sejong-si, 339-012, Republic of Korea

This page is intentionally left blank.

Oven Initial Start-up Checklist - Remove & Return to XLT Ovens

Fill out all information and print legibly

<p>Start-Up Information</p> <p>Customer Name: _____ Company Name: _____</p> <p>Phone #: _____ Email: _____</p> <p>Address: _____</p> <p>City: _____ State: _____ Zip: _____ Country: _____</p>	
<p style="text-align: center;">Follow Requirements outlined in Installation and Operation Manual</p> <p><u>Oven Install and Start-up Requirements:</u></p> <ul style="list-style-type: none"> <input type="checkbox"/> Gas Requirements met (Gas Ovens Only) <ul style="list-style-type: none"> • One shut off valve per oven installed; if not, call XLT as this may void warranty <input type="checkbox"/> Electrical Requirements met <input type="checkbox"/> Clearances met <input type="checkbox"/> Oven(s) installed and stacked properly <ul style="list-style-type: none"> • XLT is not stacked on another manufacturer's ovens; if it is, call XLT as this may void warranty <input type="checkbox"/> Oven(s) were powered on and functioned as designed <input type="checkbox"/> Conveyor chain tensioned properly upon installation 	<p style="text-align: center;">Follow Requirements outlined in Installation and Operation Manual</p> <p><u>Hood Install and Start-up Requirements:</u></p> <ul style="list-style-type: none"> <input type="checkbox"/> Electrical Requirements met <input type="checkbox"/> Clearances/ Height Requirement met <input type="checkbox"/> Hood installed properly <input type="checkbox"/> Shrouds installed properly <ul style="list-style-type: none"> • Ovens are under hood with shrouds attached <input type="checkbox"/> Ventilation Requirements met <input type="checkbox"/> Hood was powered on and functions as designed <input type="checkbox"/> Ovens function properly through the Hood
<p>Oven Information</p> <p><u>Top Oven</u></p> <p>Serial Number: _____</p> <p>Model Number: _____</p> <p><u>Middle Oven</u></p> <p>Serial Number: _____</p> <p>Model Number: _____</p> <p><u>Bottom Oven</u></p> <p>Serial Number: _____</p> <p>Model Number: _____</p>	<p>Hood Information</p> <p>Serial Number: _____</p> <p>Model Number: _____</p>



XLT Ovens
 PO Box 9090
 Wichita, KS 67277
 FAX: 316-943-2769
 Email: startup@xltovens.com

Start-up can be submitted via mail, fax, email or submit online (using QR code above or go to xltovens.com/startup).

Print Name: _____ Signature: _____ Date: _____

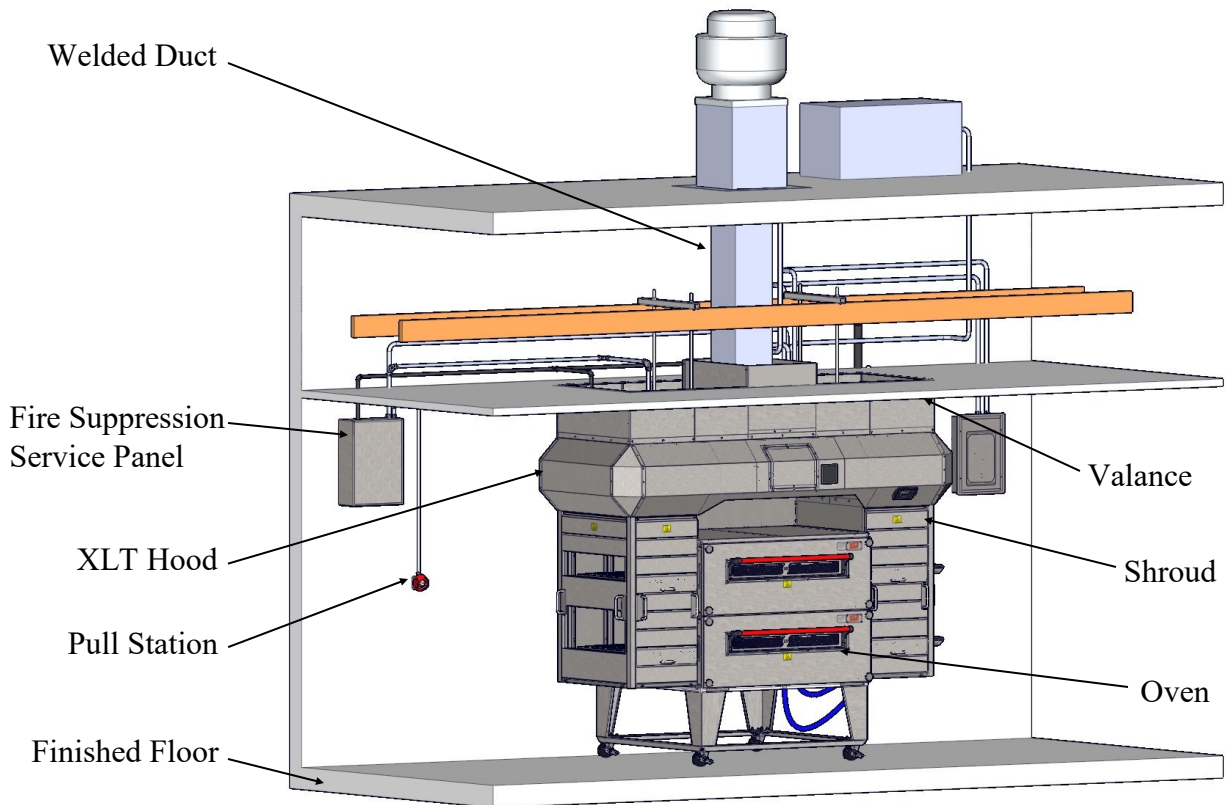
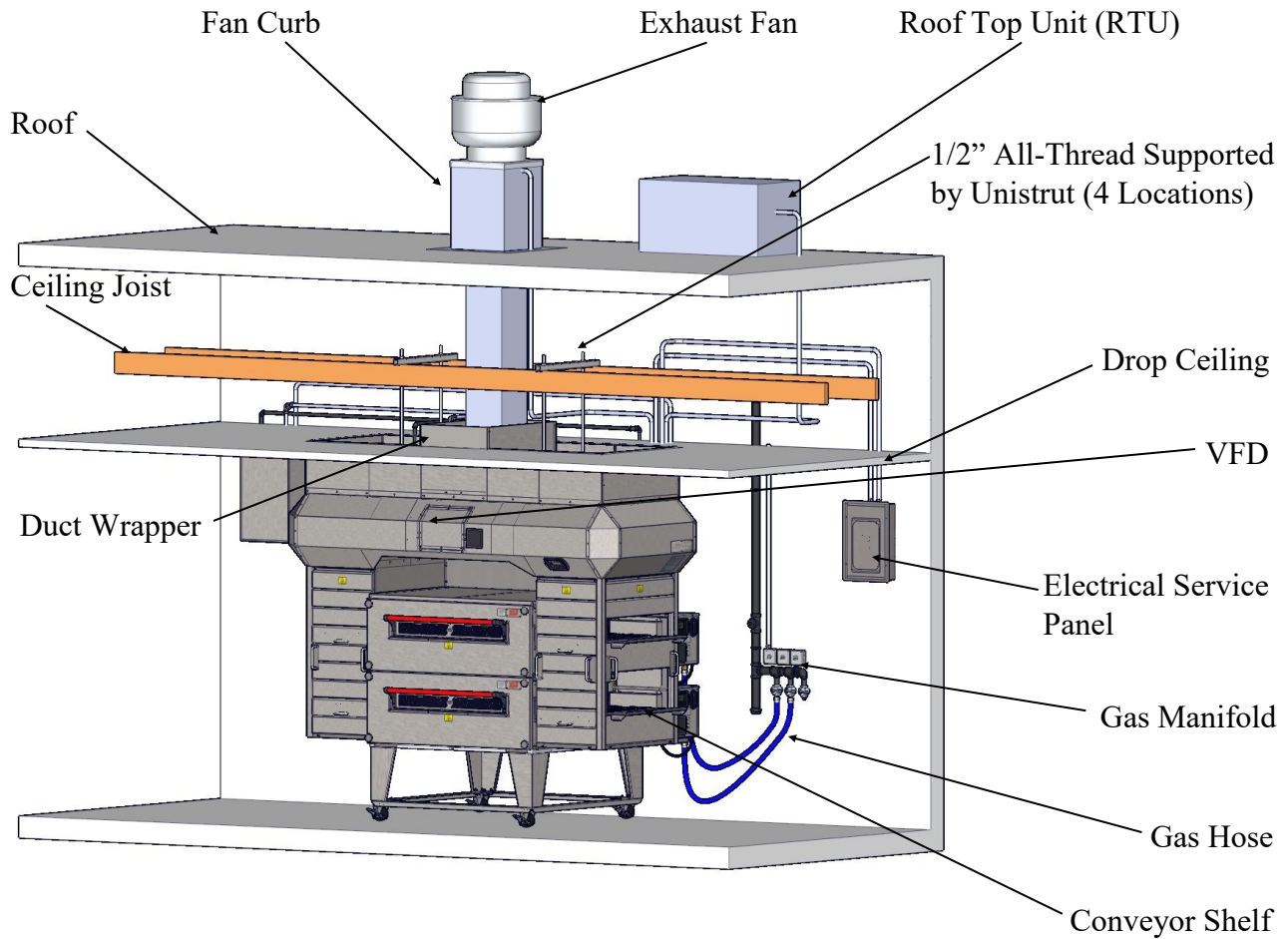

XLT Ovens
PO Box 9090
Wichita, Kansas 67277

US: 888-443-2751 FAX: 316-943-2769 INTL: 316-943-2751 WEB: www.xltovens.com